

TECHNICAL MANUAL  
UNIT MAINTENANCE MANUAL

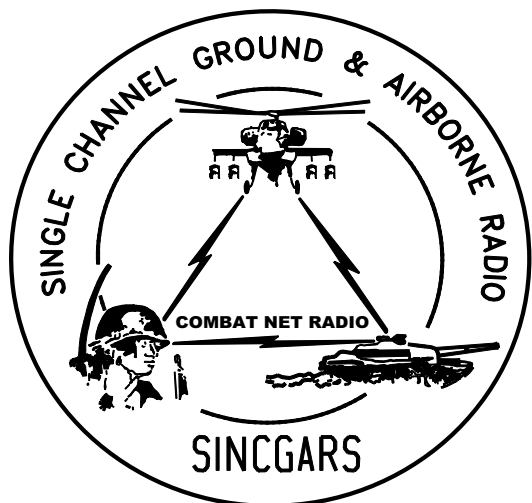

INTRODUCTION	PAGE 1-1
MANPACK RADIO	PAGE 2-1
VEHICULAR RADIOS	PAGE 3-1
CABLES	PAGE 4-1
COMPONENT REPLACEMENT/REPAIR	PAGE 5-1
SINGLE ASIP RADIO MOUNT (SARM)	PAGE 6-1

**GROUND ICOM RADIO SETS**

AN/PRC-119A	(NSN 5820-01-267-9482)	(EIC: L2Q)
AN/PRC-119D	(NSN 5820-01-421-0801)	(EIC: GC9)
AN/PRC-119F	(NSN 5820-01-451-8252)	(EIC: GA4)
AN/VRC-87A	(NSN 5820-01-267-9480)	(EIC: L22)
AN/VRC-87D	(NSN 5820-01-351-5259)	(EIC: GAR)
AN/VRC-87F	(NSN 5820-01-451-8248)	(EIC: GA5)
AN/VRC-87G	(NSN 5820-01-555-7674)	(EIC: N/A)
AN/VRC-88A	(NSN 5820-01-267-9481)	(EIC: L23)
AN/VRC-88D	(NSN 5820-01-352-1694)	(EIC: GAS)
AN/VRC-88F	(NSN 5820-01-452-8435)	(EIC: GA3)
AN/VRC-89A	(NSN 5820-01-267-9479)	(EIC: L24)
AN/VRC-89D	(NSN 5820-01-420-6619)	(EIC: GD8)
AN/VRC-89F	(NSN 5820-01-451-8247)	(EIC: GAY)
AN/VRC-90A	(NSN 5820-01-267-5105)	(EIC: L25)
AN/VRC-90D	(NSN 5820-01-420-6618)	(EIC: GD9)
AN/VRC-90F	(NSN 5820-01-451-8246)	(EIC: GA2)
AN/VRC-90G	(NSN 5820-01-555-7371)	(EIC: N/A)
AN/VRC-91A	(NSN 5820-01-267-9478)	(EIC: L26)
AN/VRC-91D	(NSN 5820-01-420-6621)	(EIC: GDG)
AN/VRC-91F	(NSN 5820-01-451-8249)	(EIC: GA8)
AN/VRC-92A	(NSN 5820-01-267-9477)	(EIC: L27)
AN/VRC-92D	(NSN 5820-01-421-2605)	(EIC: GDH)
AN/VRC-92F	(NSN 5820-01-451-8250)	(EIC: GM2)

Approved for public release; distribution is unlimited.

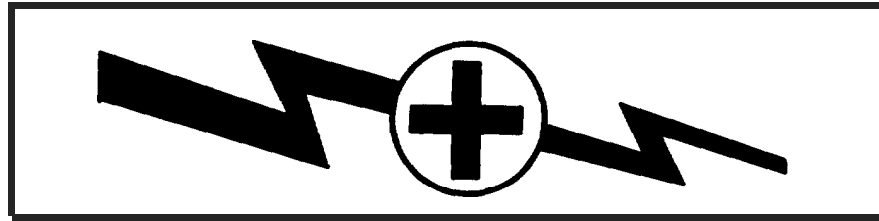

**5**

**SAFETY STEPS TO FOLLOW IF SOMEONE IS THE VICTIM OF ELECTRICAL SHOCK.**

---

**1**

**DO NOT TRY TO PULL OR GRAB THE INDIVIDUAL.**

**2**

**IF POSSIBLE, TURN OFF THE ELECTRICAL POWER.**

**3**

**IF YOU CANNOT TURN OFF THE ELECTRICAL POWER PULL, PUSH, OR LIFT THE PERSON TO SAFETY USING A DRY WOODEN POLE OR A DRY ROPE OR SOME OTHER INSULATION MATERIAL.**

**4**

**SEND FOR HELP AS SOON AS POSSIBLE.**

**5**

**AFTER THE INJURED PERSON IS FREE OF CONTACT WITH THE SOURCE OF ELECTRICAL SHOCK, MOVE THE PERSON A SHORT DISTANCE AWAY AND IMMEDIATELY START ARTIFICIAL RESUSCITATION.**



A lithium-sulfur dioxide (Li-SO<sub>2</sub>) battery used with Battery Box, CY-8523 series contains pressurized sulfur dioxide (SO<sub>2</sub>) gas (rotten egg smell). The gas is toxic, and the battery **MUST NOT** be abused in any way which may cause the battery to rupture.

**DO NOT** heat, short circuit, crush, puncture, mutilate, or disassemble the battery.

**DO NOT USE** any battery which shows signs of damage, such as bulging, swelling, disfigurement, brown liquid in the plastic wrap, a swollen plastic wrap, etc.

**DO NOT** test Li-SO<sub>2</sub> batteries for capacity, except as authorized.

**DO NOT** recharge Li-SO<sub>2</sub> batteries.

**DO NOT** use water to extinguish Li-SO<sub>2</sub> battery fires.

If the battery compartment becomes hot to the touch, if you hear a hissing sound (i.e., battery venting), or if you smell irritating sulfur dioxide gas (rotten egg smell), **IMMEDIATELY TURN Off** the equipment. Remove the equipment to a well ventilated area or leave the area.

**DO NOT** use a Halon type fire extinguisher on a lithium battery fire.

In the event of a fire near a lithium battery(ies), rapid cooling of the battery(ies) is important. Use a carbon dioxide (CO<sub>2</sub>) extinguisher.

**DO NOT** store lithium batteries with other hazardous materials and keep them away from open flame or heat.



**WARNING**

RF energy is present near the antenna during transmission. Except Manpack, maintain at least **30 inches** from antenna and personnel during transmission.

**WARNING**

**HIGH VOLTAGE**

Connectors J1 of the vehicular amplifier-adapter (VAA) and J4 of the RF power amplifier mount (PA mount) have 200 V dc on pin F Use extreme caution in measuring the voltages on these connectors.

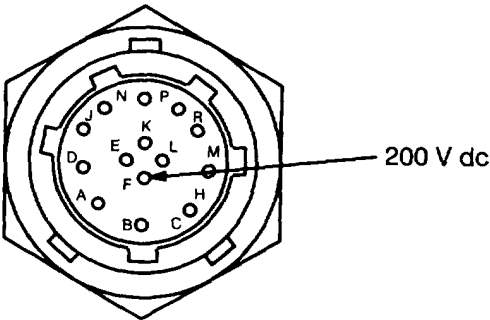

VAA J1, PA MOUNT J4

**WARNING**

**DO NOT** lift the VAA with any component installed. Maximum weight for a one-person lift is 35 lbs.

**WARNING**

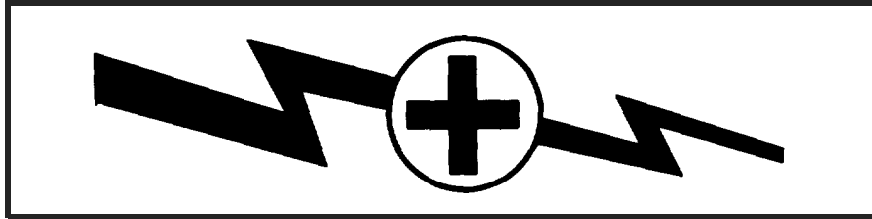

**HIGH VOLTAGE** is present during testing and troubleshooting of the radio sets. **DEATH ON CONTACT** can result, so observe the following safety precautions:

If possible, work on the equipment only when another person is nearby who is competent in **CARDIOPULMONARY RESUSCITATION (CPR)** and knows the five safety steps on page a.

Never work on electronic equipment unless there is another person nearby who is familiar with the operation and hazards of the equipment and who is competent in administering first aid. When the technicians are aided by operators, they must be warned about dangerous areas.

Whenever possible, the power supply to the equipment must be shut off before beginning work on the equipment. Take particular care to ground every capacitor likely to hold a dangerous potential. When working inside the equipment, after the power has been turned off, always ground every part before touching it.

Be careful not to contact high-voltage connections or 115 V ac input connections when installing or operating this equipment.

Whenever the nature of the operation permits, keep one hand away from the equipment to reduce the hazard of current flowing through the body.

**DO NOT BE MISLED** by the terms "low voltage" and "low potential." Voltages/potentials as low as 50 V can cause **DEATH** under certain conditions.

Remove or tape all personal metal objects (e.g., watches, rings, and medallions) before working on C-E equipment.

For Artificial Respiration, refer to FM 21-11.

---

**HARDNESS CRITICAL PROCESS**

---

The RT-1523 series of radio sets have been designed to survive the effects of a nuclear explosion. This includes over pressure and burst, thermal radiation, electromagnetic pulse (EMP), and transient radiation effects on electronics (TREE). Those maintenance procedures that are critical in maintaining the nuclear hardness of the radio are marked **HCP**

**WARNING****MOBILE OPERATION WITH WHIP ANTENNAS**

**DO NOT** stop your vehicle under power lines.

Maintain mobile communications with your antenna tied down.

Ensure that the protective antenna tip cap is on the end of your antenna.

**DO NOT** touch or stand within 30 inches (0.75 meters) of a vehicular antenna if it is possible that the RT is keyed.

When operating cross-country, do not place arm, leg, or weapon over the sides of the vehicle. If your antenna accidentally touches a power line, a fatal or serious accident can happen.

If you believe your vehicular antenna may not clear a power line, stop before you get near the power line. Carefully tie the antenna down. You may remove the antenna if necessary to ensure that it does not touch the power line.

Install a stay-down or snap-free antenna clip over the antenna. See TM 11-5820-890-10-1 for details.

**WARNING**

**Death** or serious injury can result:

- When antenna tip caps are not installed on antenna.
- When an antenna that is not tied-down hits a fixed object such as an overhead bridge, tree limb, etc., flying antenna parts might strike nearby personnel.



Change

No. 1

HEADQUARTERS  
DEPARTMENT OF THE ARMY  
Washington, DC, 3 June 2008

**UNIT MAINTENANCE MANUAL  
SINGGARS GROUND ICOM RADIO SETS**

AN/PRC-119A	(NSN 5820-01-267-9482) (EIC: L2Q)
AN/PRC-119D	(NSN 5820-01-421-0801) (EIC: GC9)
AN/PRC-119F	(NSN 5820-01-451-8252) (EIC: GA4)
AN/VRC-87A	(NSN 5820-01-267-9480) (EIC: L22)
AN/VRC-87C	(NSN 5820-01-304-2045) (EIC: GDC)
AN/VRC-87D	(NSN 5820-01-351-5259) (EIC: GAR)
AN/VRC-87F	(NSN 5820-01-451-8248) (EIC: GA5)
AN/VRC-87G	(NSN 5820-01-555-7674) (EIC: N/A)
AN/VRC-88A	(NSN 5820-01-267-9481) (EIC: L23)
AN/VRC-88D	(NSN 5820-01-352-1694) (EIC: GAS)
AN/VRC-88F	(NSN 5820-01-452-8435) (EIC: GA3)
AN/VRC-89A	(NSN 5820-01-267-9479) (EIC: L24)
AN/VRC-89D	(NSN 5820-01-420-6619) (EIC: GD8)
AN/VRC-89F	(NSN 5820-01-451-8247) (EIC: GAY)
AN/VRC-90A	(NSN 5820-01-268-5105) (EIC: L25)
AN/VRC-90D	(NSN 5820-01-420-6618) (EIC: GD9)
AN/VRC-90F	(NSN 5820-01-451-8246) (EIC: GA2)
AN/VRC-90G	(NSN 5820-01-555-7371) (EIC: N/A)
AN/VRC-91A	(NSN 5820-01-267-9478) (EIC: L26)
AN/VRC-91D	(NSN 5820-01-420-6621) (EIC: GDG)
AN/VRC-91F	(NSN 5820-01-451-8249) (EIC: GA8)
AN/VRC-92A	(NSN 5820-01-267-9477) (EIC: L27)
AN/VRC-92D	(NSN 5820-01-421-2605) (EIC: GDH)
AN/VRC-92F	(NSN 5820-01-451-8250) (EIC: GM2)

TM 11-5820-890-20-1 dated 30 December 1998 is changed as follows:

1. Remove old pages and insert new pages as indicated below. New or changed material is indicated by a vertical bar in the margin of the page. Added or revised illustrations and tables are indicated by a vertical bar adjacent to the caption or a hand pointing to the new material.
2. Chapter 6 has been added to the manual with this change. Because the entire Chapter 6 has been added no change bars/hands are used.

**Remove Pages**

i through iv  
v and 1-0  
1-1 through 1-6  
None

**Insert Pages**

i through iv/(v blank)  
(blank)/1-0  
1-1 through 1-6  
1-6.1/(1-6.2 blank)

**Remove Pages**

1-7 and 1-8  
 1-17 and 1-18  
 2-1 and 2-2  
 None  
 2-3 through 2-6  
 2-7 and 2-8  
 None  
 None  
 3-1 through 3-4  
 None  
 3-9 through 3-14  
 3-67 through (3-82 blank)  
 4-3 through 4-14  
 4-19 through 4-22  
 None  
 5-1 through 5-8  
 None  
 5-13 and 5-14  
 None  
 5-21 and 5-24  
 None  
 A-1 and A-2 blank  
 Index-1 and Index-2 blank  
 Front Cover

**Insert Pages**

1-7 and 1-8  
 1-17 and 1-18  
 2-1 and 2-2  
 2-2.1 and 2-2.2  
 2-3 through 2-6  
 2-7 and 2-7.1  
 (2-7.2 blank)/ 2-8  
 2-23 and 2-24  
 3-1 through 3-4  
 3-8.1/(3-8.2 blank)  
 3-9 through 3-14  
 3-67 through 3-83/(3-84 blank)  
 4-3 through 4-14  
 4-19 through 4-22  
 4-25 and 4-26  
 5-1 through 5-8  
 5-8.1/(5-8.2 blank)  
 5-13 and 5-14  
 5-18.1 and 5-18.2  
 5-21 and 5-24  
 6-1 through 6-42  
 A-1/(A-2 blank)  
 Index -1 through Index-3/(Index-4blank)  
 Front Cover

3. File this change sheet in front of the publication for reference purposes.

Approved For Public Release; Distribution Is Unlimited.

By Order of the Secretary of the Army:

Official:



JOYCE E. MORROW

*Administrative Assistant to the  
Secretary of the Army*

0816303

GEORGE W. CASEY, JR  
*General, United States Army  
Chief of Staff*

DISTRIBUTION:

To be distributed in accordance with the initial distribution number (IDN) 511756 requirements for  
TM 11-5820-890-20-1





**LIST OF EFFECTIVE PAGES**

INSERT LATEST CHANGED PAGES, DESTROY SUPERSEDED PAGES

NOTE: The portion of the text affected by the changes is indicated by a vertical line in the outer margins of the page. Changes to illustrations are indicated by miniature pointing hands or a vertical bar at the end of the title.

**Dates of issue for original and changed pages are:**

Original .....0 ..... 30 December 1998  
 Change .....1 .....3 June 2008

Page No.	Change No.	Page No.	Change No.
Cover/blank.....	1	4-15 thru 4-18 .....	0
a thru d.....	0	4-19.....	1
e/(f blank).....	0	4-20.....	0
i thru iii .....	1	4-21 and 4-22 .....	1
iv(v blank) .....	0	4-23 and 4-24 .....	0
<b>Chapter 1</b>		4-25 and 4-26 .....	1
1-0 thru 1-6 .....	1	<b>Chapter 5</b>	
1-6.1/(1-6.2 blank) .....	1	5-1 thru 5-6 .....	1
1-7 and 1-8 .....	1	5-7.....	0
1-9 thru 1-16 .....	0	5-8.....	1
1-17 and 1-18 .....	1	5-8.1/(5-8.2 blank) .....	1
1-19 thru 1-24 .....	0	5-9 thru 5-12 .....	0
<b>Chapter 2</b>		5-13 and 5-14 .....	1
2-1 and 2-2 .....	1	5-15 thru 5-18 .....	0
2-2.1 and 2-2.2 .....	1	5-18.1 and 5-18.2 .....	1
2-3 and 2-4 .....	1	5-19 and 5-20 .....	0
2-5 .....	0	5-21 and 5-22 .....	1
2-6 and 2-7 .....	1	5-23.....	0
2-7.1.....	1	5-24.....	1
(2-7.2 blank)/2-8 .....	1	<b>Chapter 6</b>	
2-9 thru 2-22 .....	0	6-1 thru 6-42 .....	1
2-23 and 2-24 .....	1	<b>Appendix</b>	
<b>Chapter 3</b>		A-1/(A-2 blank).....	1
3-1 .....	1	B-1/(B-2 blank).....	0
3-2 .....	0	C-1/(C-2 blank) .....	0
3-3 and 3-4 .....	1	<b>Index</b>	
3-5 thru 3-8 .....	0	Index-1 and Index-2.....	1
3-8.1/(3-8.2 blank) .....	1	Index-3/(Index-4 blank).....	1
3-9 .....	0		
3-10 thru 3-13 .....	1		
3-14 thru 3-66 .....	0		
3-67 thru-3-82 .....	1		
3-83/(3-84 blank) .....	1		
<b>Chapter 4</b>			
4-1 and 4-2 .....	0		
4-3 .....	1		
4-4 .....	0		
4-5 and 4-6 .....	1		
4-7 .....	0		
4-8 thru 4-14 .....	1		



**Technical Manual  
Unit Maintenance Manual  
Ground ICOM Radio Sets:**

AN/PRC-119A	(NSN 5820-01-267-9482)	(EIC: L2Q)
AN/PRC-119D	(NSN 5820-01-421-0801)	(EIC: GC9)
AN/PRC-119F	(NSN 5820-01-451-8252)	(EIC: GA4)
AN/VRC-87A	(NSN 5820-01-267-9480)	(EIC: L22)
AN/VRC-87D	(NSN 5820-01-351-5259)	(EIC: GAR)
AN/VRC-87F	(NSN 5820-01-451-8248)	(EIC: GA5)
AN/VRC-87G	(NSN 5820-01-555-7674)	(EIC: N/A)
AN/VRC-88A	(NSN 5820-01-267-9481)	(EIC: L23)
AN/VRC-88D	(NSN 5820-01-352-1694)	(EIC: GAS)
AN/VRC-88F	(NSN 5820-01-452-8435)	(EIC: GA3)
AN/VRC-89A	(NSN 5820-01-267-9479)	(EIC: L24)
AN/VRC-89D	(NSN 5820-01-420-6619)	(EIC: GD8)
AN/VRC-89F	(NSN 5820-01-451-8247)	(EIC: GAY)
AN/VRC-90A	(NSN 5820-01-267-5105)	(EIC: L25)
AN/VRC-90D	(NSN 5820-01-420-6618)	(EIC: GD9)
AN/VRC-90F	(NSN 5820-01-451-8246)	(EIC: GA2)
AN/VRC-90G	(NSN 5820-01-555-7371)	(EIC: N/A)
AN/VRC-91A	(NSN 5820-01-267-9478)	(EIC: L26)
AN/VRC-91D	(NSN 5820-01-420-6621)	(EIC: GDG)
AN/VRC-91F	(NSN 5820-01-451-8249)	(EIC: GA8)
AN/VRC-92A	(NSN 5820-01-267-9477)	(EIC: L27)
AN/VRC-92D	(NSN 5820-01-421-2605)	(EIC: GDH)
AN/VRC-92F	(NSN 5820-01-451-8250)	(EIC: GM2)

**REPORTING ERRORS AND RECOMMENDING IMPROVEMENTS**

You can help improve this manual. If you find any mistakes, or if you know a way to improve the procedures, please let us know. We'd prefer that you submit your recommended changes electronically, either by e-mail (AMSELLCLEOPUBSCHG@conus.army.mil) or a (http://edm.monmouth.army.mil/pubs/2028.html). Alternatively, you may mail or fax your letter, DA Form 2028 (Recommended Changes to Publications and Blank Forms) or DA Form 2028 located in back of this manual to : Commander, US Army CECOM Life Cycle Management Command (LCMC), Fort Monmouth, ATTN: AMSEL-LC-LEO-E-ED, Fort Monmouth, NJ 07703-5006. The fax number is 732-532-1556, DSN 992-1556. In any case, we will send you a reply.

**TABLE OF CONTENTS**

<u>Chap/Sec/Para</u>	<u>Subject</u>	<u>Page</u>
	<b>HOW TO USE THIS MANUAL</b> .....	iii
<b>CHAPTER 1</b>	<b>INTRODUCTION</b> .....	1-1
<b>Section I</b>	<b>General Information</b> .....	1-1
Para 1.1	Scope .....	1-1
Para 1.2	Consolidated Index of Army Publications .....	1-6
Para 1.3	Reporting Equipment Improvement Recommendations (EIR) .....	1-6
Para 1.4	Maintenance Forms, Records, and Reports .....	1-6
Para 1.5	Destruction of Army Electronics Materiel .....	1-6
Para 1.6	Preparation for Storage or Shipment .....	1-6
Para 1.7	Nomenclature Cross-Reference List .....	1-6

<u>Chap/Sec/Para</u>	<u>Subject</u>	<u>Page</u>
<b>Section II</b>	<b>Principles of Operation</b> .....	1-9
Para 1.8	General .....	1-9
Para 1.9	DC Power Input and Distribution .....	1-9
Para 1.10	Receive Signal Path .....	1-15
Para 1.11	Transmit Signal Path .....	1-15
Para 1.12	Frequency Hopping Operation .....	1-17
Para 1.13	Time Management .....	1-17
Para 1.14	RT Main Panel Displays .....	1-18
Para 1.15	RT Self-Test (RT-1523 Through RT-1523D) .....	1-19
Para 1.16	RT Self-Test (RT-1523E/F) .....	1-19
Para 1.17	Power Amplifier .....	1-20
<b>Section III</b>	<b>Principles of Maintenance Operation</b> .....	1-21
Para 1.18	Use of Maintenance Allocation Chart (MAC) .....	1-21
Para 1.19	Unscheduled Maintenance .....	1-21
Para 1.20	Troubleshooting .....	1-21
Para 1.21	Post-Repair Use of Operational Check .....	1-22
Para 1.22	Typical SC Test Setup .....	1-22
<b>Section IV</b>	<b>Preparation for Storage or Shipment</b> .....	1-23
Para 1.23	General .....	1-23
Para 1.24	Special Procedures .....	1-23
Para 1.25	Administrative Storage .....	1-23
Para 1.26	Intermediate Storage .....	1-24
<b>CHAPTER 2</b>	<b>MANPACK RADIO</b> .....	2-1
Para 2.1	Assembly .....	2-1
Para 2.2	Operational Check .....	2-3
Para 2.3	Troubleshooting Flowcharts .....	2-8.1
<b>CHAPTER 3</b>	<b>VEHICULAR RADIOS</b> .....	3-1
Para 3.1	Operational Check .....	3-1
Para 3.2	Troubleshooting Flowcharts .....	3-9
<b>CHAPTER 4</b>	<b>CABLES</b> .....	4-1
Para 4.1	Troubleshooting .....	4-1
Para 4.2	Schematics .....	4-3
<b>CHAPTER 5</b>	<b>COMPONENT REPLACEMENT/REPAIR</b> .....	5-1
Para 5.1	Inspection Procedures .....	5-1
Para 5.2	Component Replacement .....	5-4
Para 5.3	Component Repair .....	5-13
<b>CHAPTER 6</b>	<b>SINGLE ASIP RADIO MOUNT (SARM)</b> .....	6-1
Para 6.1	Principles of Operation .....	6-1
Para 6.2	Operation Check .....	6-6
Para 6.3	Troubleshooting Flowcharts .....	6-12
<b>INDEX</b>	<b>SUBJECT MATTER INDEX</b> .....	INDEX-1
<b>APPENDIX A</b>	<b>REFERENCES</b> .....	A-1
<b>APPENDIX B</b>	<b>MAINTENANCE ALLOCATION CHART (See TM 11-5820-890-20-2)</b>	
<b>APPENDIX C</b>	<b>EXPENDABLE/DURABLE SUPPLIES AND MATERIALS LIST</b> .....	C-1
Section I	Introduction .....	C-1
Section II	Expendable/Durable Supplies And Materials List .....	C-1
<b>POWER DISTRIBUTION DIAGRAMS (See TM 11-5820-890-20-2)</b>		

## HOW TO USE THIS MANUAL

### OBJECTIVE.

The goal of this technical manual is to provide unit maintenance procedures that are easy to understand and is equally easy to follow when operating in the field.

### MANUALS.

Three technical manuals support the unit maintainer:

**TM 11-5820-890-20-1** (Short title: TM 20-1) focuses on SINGARS radios, both manpack and vehicular configurations, single ASIP radio mount (SARM), and provides essential information regarding cables, component replacement and repair. By limiting TM 20-1 to this primary focus, the manual is small enough to be carried around by the maintainer during field operations if required.

**TM 11-5820-890-20-2** (Short title: TM 20-2) supplements TM 20-1 with maintenance procedures regarding other system components. These include vehicular intercommunications system (VIC), frequency-hopping multiplexer (FHMUX), control-monitor (C-M), remote control unit (RCU), single radio mount (SRM), FH fill devices, batteries, handheld remote control radio device (HRCDR), and control display unit (CDU). Additionally, TM 20-2 includes the maintenance allocation chart and power distribution diagrams. TM 20-2 is necessarily larger than TM 20-1, and it is designed primarily for use under shelter.

**TM 11-5820-890-20-3**, Unit Maintenance Handbook (Short title: TM 20-3) is the third manual. This is a logbook size manual designed to be routinely carried by each unit maintainer while checking out communications systems installed in vehicles and in field locations. The information contained in this handbook is extracted from TM 20-1 and TM 20-2, but the manual's useful size obviously limits the amount of information provided. The guidance found in the handbook is accurate. It is just not as detailed as that found in TM 20-1 and TM 20-2 .

Unit maintenance personnel are encouraged to use all three manuals. The handbook is carried on their person for on-site, in the field, troubleshooting and faulty line replaceable unit (LRU) identification. TM 20-1 and TM 20-2 are then used to confirm handbook-based findings, or to extend troubleshooting procedures where the handbook fails to disclose which LRU is faulty.

### PRINCIPLES OF OPERATION.

Where appropriate, TM 20-1 and TM 20-2 provide background information of general interest in understanding how the system or component works.

### OPERATIONAL CHECKS.

Each chapter of TM 20-1 and TM 20-2, where applicable, contains Operational Checks. This is where the unit maintainer starts to identify the nature of the problem. As these manuals caution, it is important to perform Operational Checks exactly as presented, or false findings can result. The second important application of the Operational Check is its use after LRU replacement, or repair, to verify that the fault has been corrected. The Operational Check for manpack and vehicular radios found in TM 20-3, Unit Maintenance Handbook, are identical to those provided in TM 20-1. Operational checks for other items of equipment are shown in TM 20-2 only.

## **TROUBLESHOOTING FLOWCHARTS.**

Each chapter of TM 20-1 and TM 20-2, where applicable, contains Troubleshooting Flowcharts. Which flowchart to use is determined by the Operational Check. Use of the troubleshooting flowchart then identifies the specific problem and tells the maintainer to replace, or repair, a specific LRU.

The Unit Maintenance Handbook, TM 20-3, contains abbreviated troubleshooting flowcharts called Troubleshooting Guides. Guides are shorter than flowcharts to permit their use in a logbook sized handbook. Experience has shown that by using these abbreviated troubleshooting guides, a unit maintainer is able to correctly identify system problems. When use of the troubleshooting guides fails to properly identify the problem, or there is a question about the accuracy of the problem identification, the unit maintainer should use TM 20-1 or TM 20-2 with their more extensive troubleshooting flowcharts. The purpose of the handbook is to help the unit maintainer when working inside vehicles in the field, but the procedures contained in the handbook may be supplemented with those in TM 20-1 and TM 20-2.

## **SYSTEM VERSUS COMPONENTS.**

The Operational Checks and troubleshooting flowcharts/guides found in TM 20-1, TM 20-2, and TM 20-3 are based upon the requirement to check systems rather than components. For example, a problem with the radio in a vehicle must be checked in the vehicle, not by removing the RT and taking it elsewhere to be checked. Once the vehicular radio system has been checked and a specific LRU identified as faulty, that LRU can be taken elsewhere for further checking. When the radio system being checked includes an AN/VIC-1 (VIC), check first to determine if the fault is in the radio or the VIC. Then troubleshoot the faulty part of the system.

## **AVOIDING FALSE PULLS.**

When properly used, these three TMs offer the unit maintainer the means for accurately identifying nearly all faulty LRUs. The number of problems which can occur in radio systems and the detailed procedures required for accurate identification dictate that manuals must be used even under the most adverse field conditions. Attempts to troubleshoot from memory have proven over and over to result in false pulls, reflecting adversely on the unit maintainer and helping no one. Four sure ways to keep false pulls to an absolute minimum are: (1) start by performing the prescribed Operational Check; (2) use these manuals when troubleshooting; (3) confirm your fault identification by again performing the Operational Check; and (4) use TM 20-1 and TM 20-2 troubleshooting flowcharts to double-check faulty LRUs before evacuating them to direct support (DS) maintenance.



**MAIN COMPONENTS OF RT-1523 SERIES RADIO SETS AND INSTALLATION KITS**

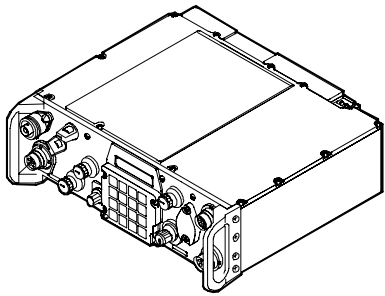

**RECEIVER-TRANSMITTER,  
RADIO (RT)  
RT-1523 SERIES**

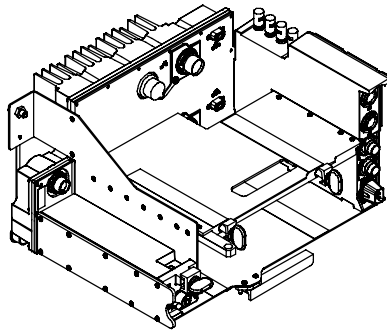

**AMPLIFIER-ADAPTER,  
VEHICULAR (VAA)  
AM-7239 SERIES**

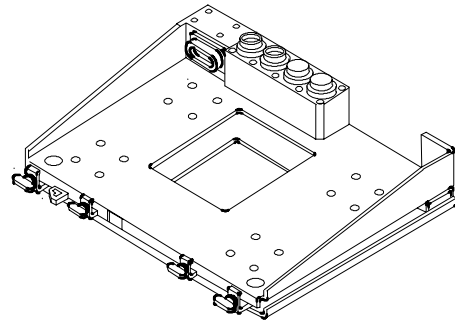

**MOUNTING BASE,  
ELECTRICAL EQUIPMENT (MB)  
MT-6352/VRC  
MT-6352A/VRC**

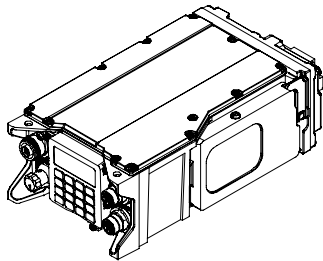

**RECEIVER-TRANSMITTER,  
RADIO (RT)  
RT-1523E(C)/U  
RT-1523F(C)/U**

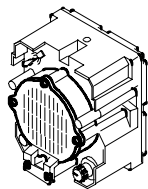

**LOUDSPEAKER-  
CONTROL UNIT  
LS-671/VRC**

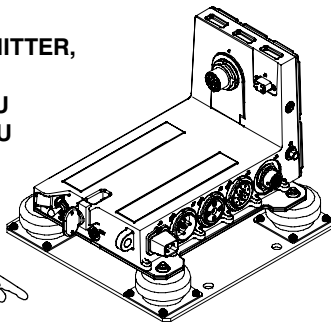

**ADAPTER, POWER  
SUPPLY (PSA)  
MX-12275/VRC**



**ANTENNA,  
MANPACK  
AS-3683/PRC**



**ANTENNA,  
MANPACK  
AS-4266A/PRC**

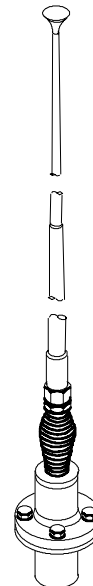

**ANTENNA,  
VEHICULAR  
AS-3900A/VRC**

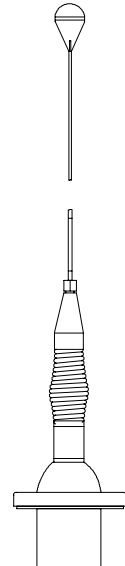

**ANTENNA,  
VEHICULAR  
AS-3916/VRC**

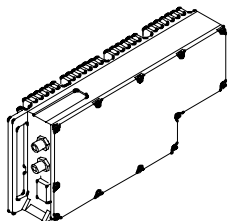

**AMPLIFIER, RADIO  
FREQUENCY (PA)  
AM-7238 SERIES**

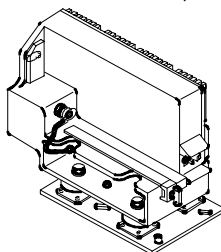

**MOUNTING BASE,  
ELECTRICAL  
EQUIPMENT  
(PA MOUNT)  
MT-6353/VRC**

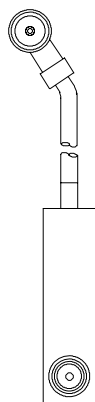

**CABLE ASSEMBLY,  
SPECIAL PURPOSE,  
ELECTRICAL  
(VIC INTERFACE CABLE)  
CX-13313/VRC**

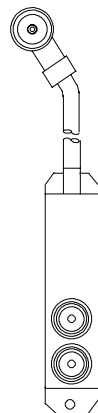

**CABLE ASSEMBLY,  
SPECIAL PURPOSE,  
ELECTRICAL  
(SPLITTER CABLE)  
CX-13417/VRC**

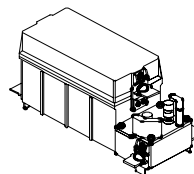

**BATTERY BOX  
CY-8523A/PRC  
CY-8523B/PRC  
CY-8523C/PRC**

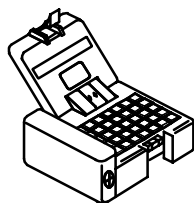

**AUTOMATED NET CONTROL  
DEVICE (ANCD) AN/CYZ-10**

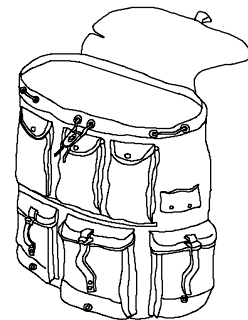

**FIELD PACK,  
COMBAT NYLON**



# CHAPTER 1

## INTRODUCTION

Subject	Section	Page
General Information .....	I	1-1
Principles of Operation .....	II	1-8
Principles of Maintenance Operation .....	III	1-19
Preparation for Storage or Shipment .....	IV	1-21

## SECTION I

### GENERAL INFORMATION

#### 1.1. SCOPE.

- a. **Type of Manual.** This is a unit maintenance manual. It contains information required to maintain the RT-1523 series radios and/or ancillary equipment.
- b. **Model Numbers and Equipment Names.**

**Radio Sets Using  
RT-1523 Series**

**Common Name**

AN/PRC-119A	Manpack radio
AN/PRC-119D	Manpack radio
AN/PRC-119F	Manpack radio
AN/VRC-87A	Short range radio
AN/VRC-87D	Short range radio
AN/VRC-87F	Short range radio
AN/VRC-87G	Short range radio in single ASIP radio mount
AN/VRC-88A	Short range radio with dismount equipment
AN/VRC-88D	Short range radio with dismount equipment
AN/VRC-88F	Short range radio with dismount equipment
AN/VRC-89A	Short range and long range radio
AN/VRC-89D	Short range and long range radio
AN/VRC-89F	Short range and long range radio
AN/VRC-90A	Long range radio
AN/VRC-90D	Long range radio
AN/VRC-90F	Long range radio
AN/VRC-90G	Long range radio in single ASIP radio mount
AN/VRC-91A	Short range and long range radio with dismount equipment
AN/VRC-91D	Short range and long range radio with dismount equipment
AN/VRC-91F	Short range and long range radio with dismount equipment
AN/VRC-92A	Dual long range radio
AN/VRC-92D	Dual long range radio
AN/VRC-92F	Dual long range radio

- c. **Purpose and Use of Equipment.** All types of SINGARS ICOM radio sets use the RT-1523 series as the basic receiver-transmitter. They can operate in single channel (SC) mode or in the frequency hopping (FH) mode. In either mode the RT can receive and transmit voice, and analog or digital data. The RT has a self-test function, retransmit capabilities, and can be remotely controlled. External COMSEC equipment is not required when using the RT-1523 series. Secure communications functions are built into the RT.

1.1. SCOPE. Continued

d. Components of Radio Sets.

**AN/PRC-119A/D/F MANPACK RADIO**

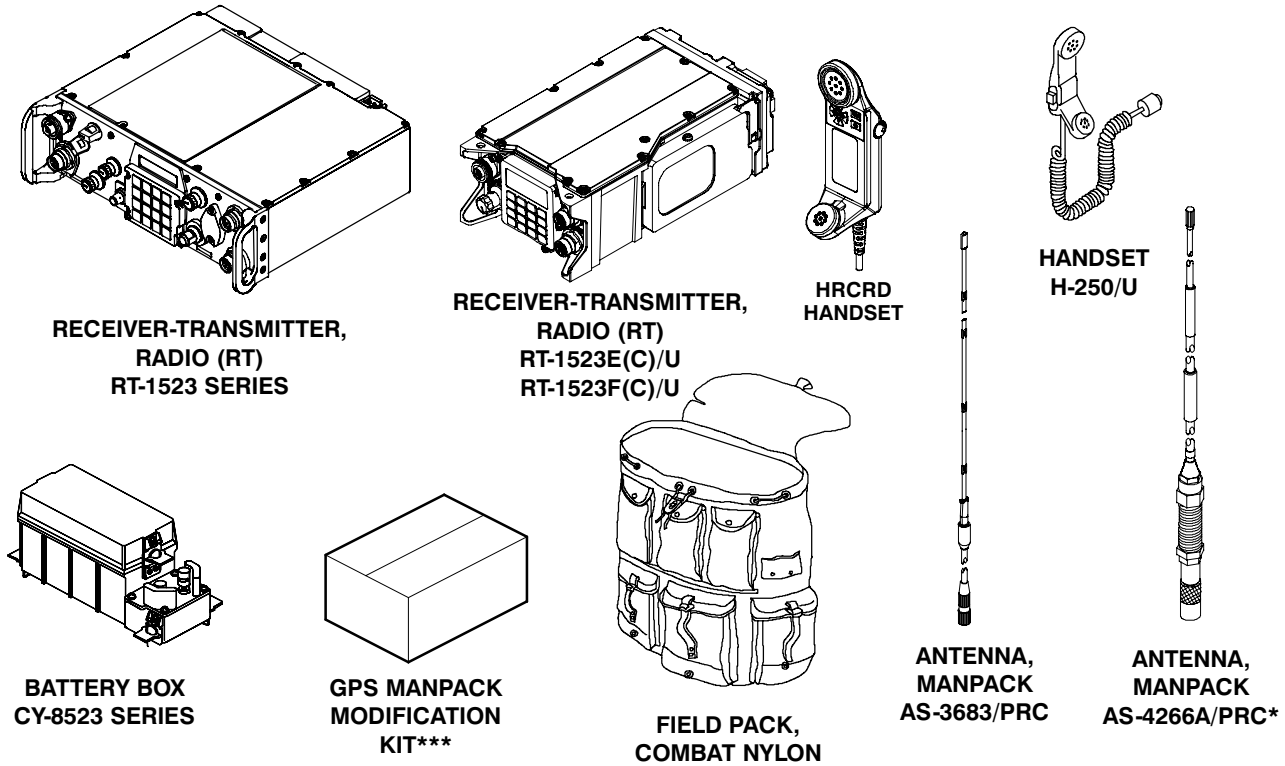

**AN/VRC-87A/D/F SHORT RANGE RADIO**

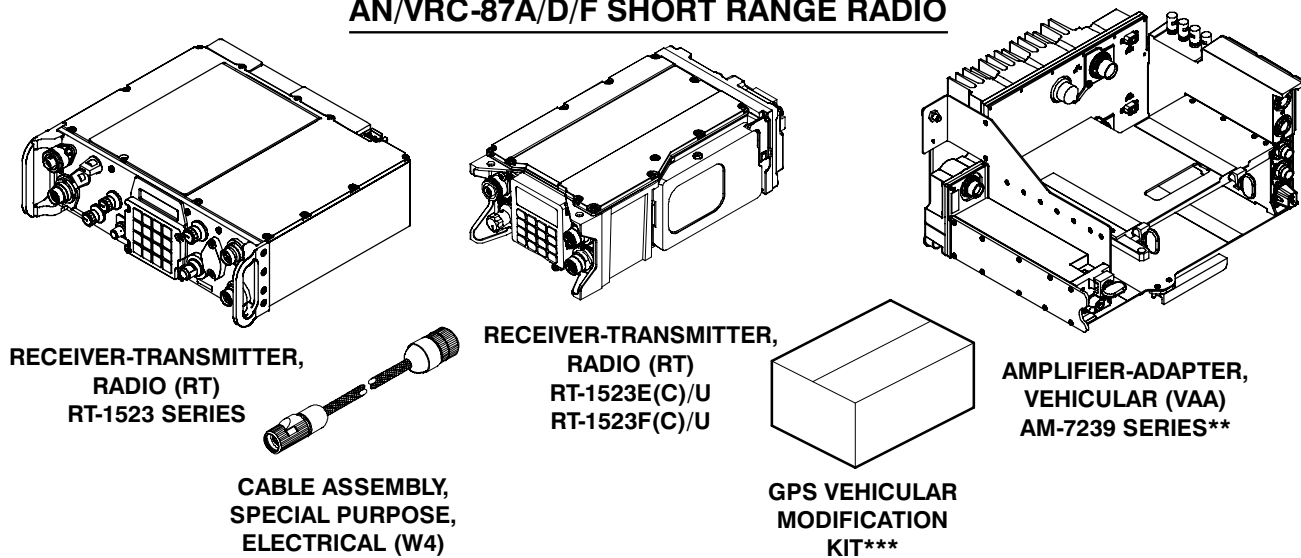

\* Additional Authorized List item

\*\* RT-1523A will not fit into AM-7239E and will not fit into AM-7239C without removal of rear GPS connectors.

\*\*\* Additional Authorized List item used with RT-1523E/F only.

1.1. **SCOPE.** Continued

d. **Components of Radio Sets.** Continued

**AN/VRC-88A/D/F SHORT RANGE RADIO WITH DISMOUNT EQUIPMENT**

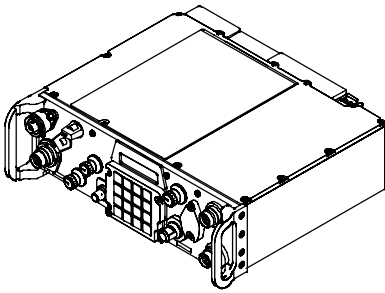

**RECEIVER-TRANSMITTER,  
RADIO (RT)  
RT-1523 SERIES**

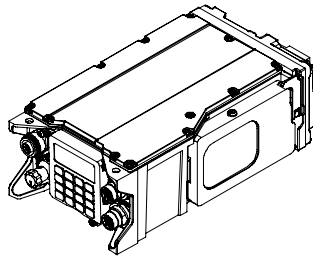

**RECEIVER-TRANSMITTER,  
RADIO (RT)  
RT-1523E(C)/U  
RT-1523F(C)/U**

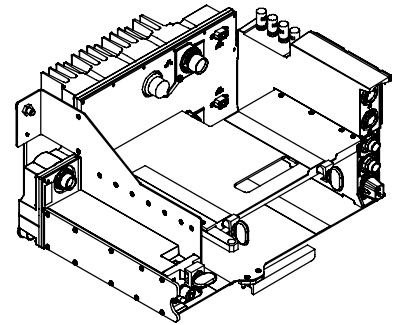

**AMPLIFIER-ADAPTER,  
VEHICULAR (VAA)  
AM-7239 SERIES\*\***

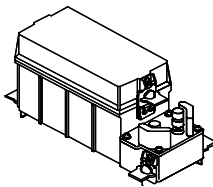

**BATTERY BOX  
CY-8523 SERIES**

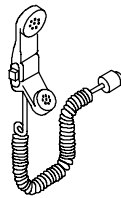

**HANDSET  
H-250/U**

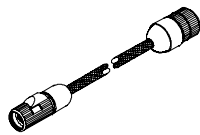

**CABLE ASSEMBLY,  
SPECIAL PURPOSE,  
ELECTRICAL (W4)**



**ANTENNA,  
MANPACK  
AS-3683/PRC**



**ANTENNA,  
MANPACK  
AS-4266A/PRC\***

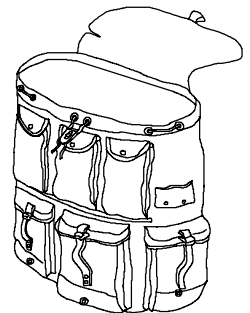

**FIELD PACK,  
COMBAT NYLON**

\* Additional Authorized List item

\*\* RT-1523A will not fit into AM-7239E and will not fit into AM-7239C without removal of rear GPS connectors

1.1. **SCOPE.** Continued

d. **Components of Radio Sets.** Continued

**AN/VRC-89A/D/F SHORT RANGE AND LONG RANGE RADIO**

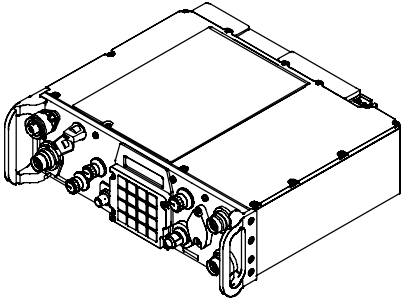

**RECEIVER-TRANSMITTER,  
RADIO (RT)  
RT-1523 SERIES  
(TWO EACH ANY  
COMBINATION)**

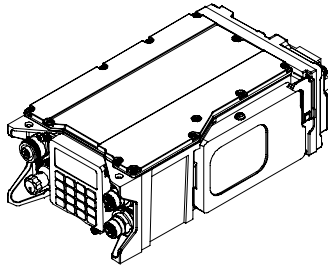

**RECEIVER-TRANSMITTER,  
RADIO (RT)  
RT-1523E(C)/U  
RT-1523F(C)/U**

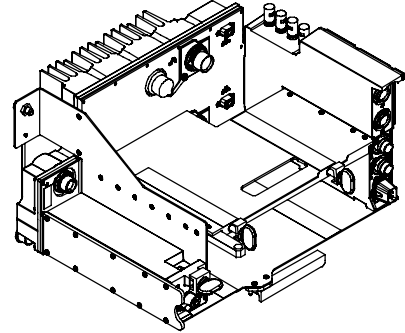

**AMPLIFIER-ADAPTER,  
VEHICULAR (VAA)  
AM-7239 SERIES\*\***

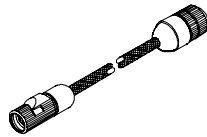

**CABLE ASSEMBLY,  
SPECIAL PURPOSE,  
ELECTRICAL (W4)  
(TWO EACH)**

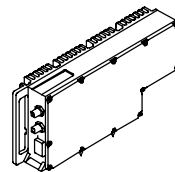

**AMPLIFIER, RADIO  
FREQUENCY (PA)  
AM-7238 SERIES**

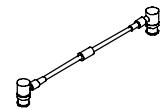

**CABLE ASSEMBLY, RADIO  
FREQUENCY (W2)**

**AN/VRC-90A/D/F LONG RANGE RADIO**

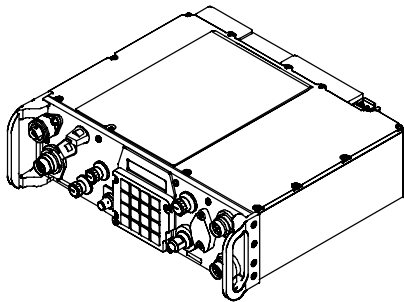

**RECEIVER-TRANSMITTER,  
RADIO (RT)  
RT-1523 SERIES**

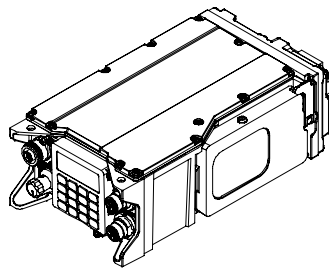

**RECEIVER-TRANSMITTER,  
RADIO (RT)  
RT-1523E(C)/U  
RT-1523F(C)/U**

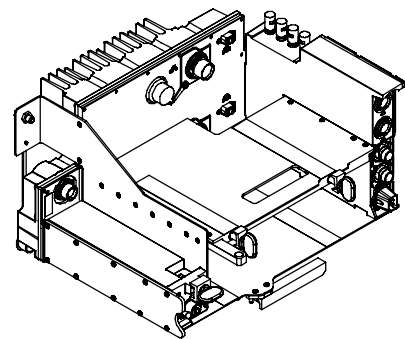

**AMPLIFIER-ADAPTER,  
VEHICULAR (VAA)  
AM-7239 SERIES\*\***

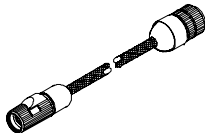

**CABLE ASSEMBLY,  
SPECIAL PURPOSE,  
ELECTRICAL (W4)**

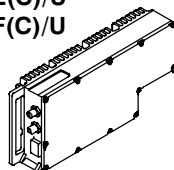

**AMPLIFIER, RADIO  
FREQUENCY (PA)  
AM-7238 SERIES**

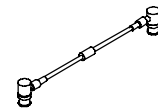

**CABLE ASSEMBLY, RADIO  
FREQUENCY (W2)**

\* Additional Authorized List item

\*\* RT-1523A will not fit into AM-7239E and will not fit into AM-7239C without removal of rear GPS connectors

1.1. SCOPE. Continued

d Components of Radio Sets. Continued

**AN/VRC-91A/D/F SHORT RANGE AND LONG RANGE RADIO WITH DISMOUNT EQUIPMENT**

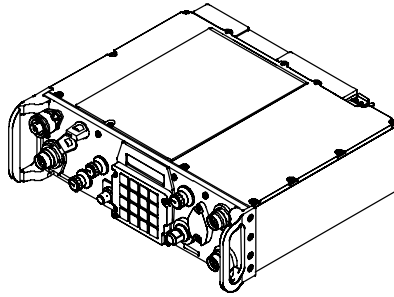

**RECEIVER-TRANSMITTER,  
RADIO (RT)  
RT-1523 SERIES  
(TWO EACH ANY  
COMBINATION)**

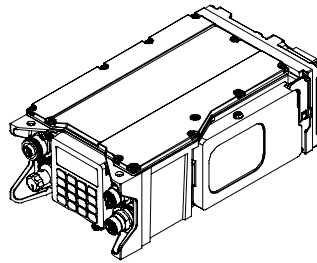

**RECEIVER-TRANSMITTER,  
RADIO (RT)  
RT-1523E(C)/U  
RT-1523F(C)/U**

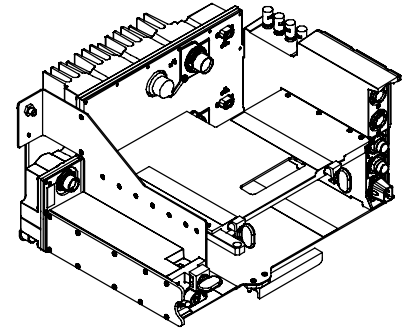

**AMPLIFIER-ADAPTER,  
VEHICULAR (VAA)  
AM-7239 SERIES\*\***

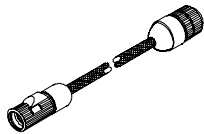

**CABLE ASSEMBLY,  
SPECIAL PURPOSE,  
ELECTRICAL (W4)  
(TWO EACH)**

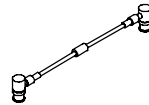

**CABLE ASSEMBLY, RA-  
DIO FREQUENCY (W2)**

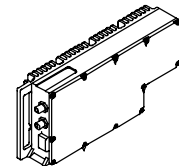

**AMPLIFIER, RADIO  
FREQUENCY (PA)  
AM-7238 SERIES**

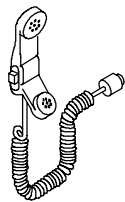

**HANDSET  
H-250/U**

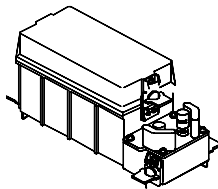

**BATTERY BOX  
CY-8523 SERIES**

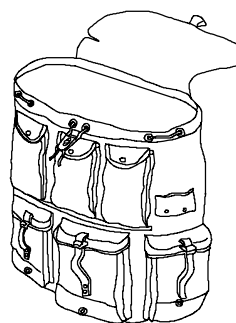

**FIELD PACK,  
COMBAT NYLON**



**ANTENNA,  
MANPACK  
AS-3683/PRC**

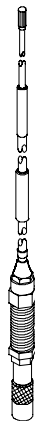

**ANTENNA,  
MANPACK  
AS-4266A/PRC\***

\* Additional Authorized List item

\*\* RT-1523A will not fit into AM-7239E and will not fit into AM-7239C without removal of rear GPS connectors.

1.1. SCOPE. Continued

d Components of Radio Sets. Continued

**AN/VRC-92A/D/F DUAL LONG RANGE RADIO**

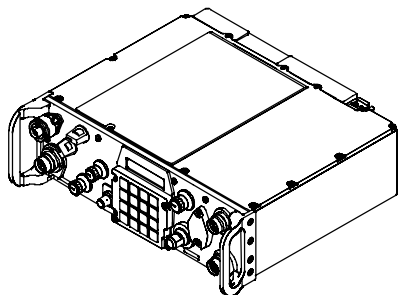

RECEIVER-TRANSMITTER,  
RADIO (RT)  
RT-1523 SERIES  
(TWO EACH ANY  
COMBINATION)

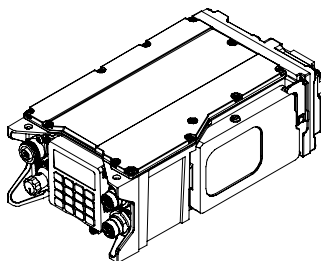

RECEIVER-TRANSMITTER,  
RADIO (RT)  
RT-1523E(C)/U  
RT-1523F(C)/U

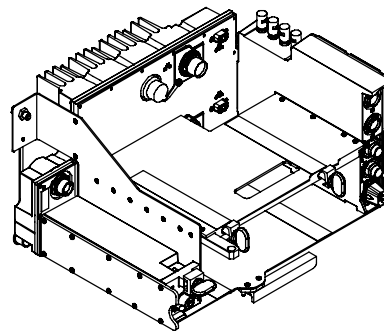

AMPLIFIER-ADAPTER,  
VEHICULAR (VAA)  
AM-7239 SERIES\*

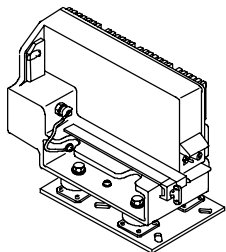

MOUNTING BASE,  
ELECTRICAL EQUIPMENT  
(PA MOUNT)  
MT-6353/VRC

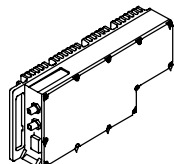

AMPLIFIER, RADIO  
FREQUENCY (PA)  
AM-7238 SERIES  
(TWO EACH ANY  
COMBINATION)

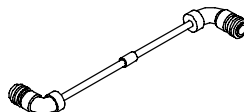

CABLE ASSEMBLY,  
SPECIAL PURPOSE,  
ELECTRICAL  
CX-13291/VRC

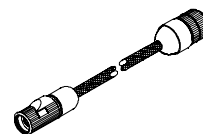

CABLE ASSEMBLY,  
SPECIAL PURPOSE,  
ELECTRICAL (W4)  
(TWO EACH)

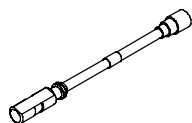

CABLE ASSEMBLY,  
SPECIAL PURPOSE,  
ELECTRICAL  
CX-13298/VRC

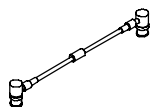

CABLE ASSEMBLY,  
RADIO FREQUENCY  
CG-3856/VRC

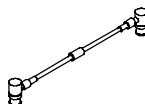

CABLE ASSEMBLY,  
RADIO FREQUENCY W2  
CG-3856/VRC

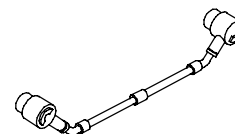

CABLE ASSEMBLY,  
POWER, ELECTRICAL  
CX-13303/VRC

\* RT-1523A will not fit into AM-7239E and will not fit into AM-7239C without removal of rear GPS connectors.

1.1. SCOPE. Continued

d Components of Radio Sets. Continued

**AN/VRC-87G SHORT RANGE RADIO  
IN SINGLE ASIP RADIO MOUNT**

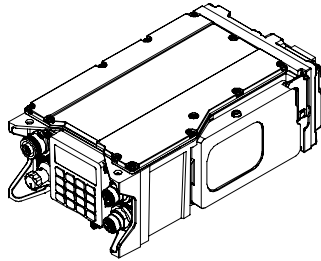

RECEIVER-TRANSMITTER,  
RADIO (RT)  
RT-1523E(C)/U  
RT-1523F(C)/U

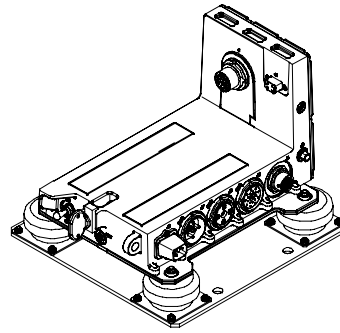

ADAPTER, POWER SUPPLY (PSA)  
MX-12275/VRC

**AN/VRC-90G LONG RANGE RADIO  
IN SINGLE ASIP RADIO MOUNT**

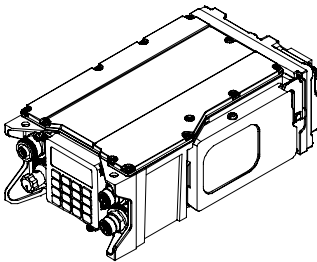

RECEIVER-TRANSMITTER,  
RADIO (RT)  
RT-1523E(C)/U  
RT-1523F(C)/U

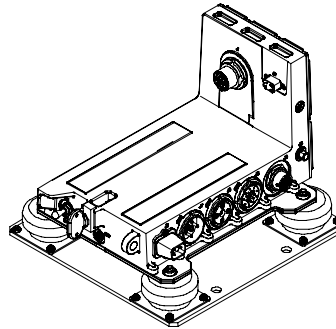

ADAPTER, POWER SUPPLY (PSA)  
MX-12275/VRC

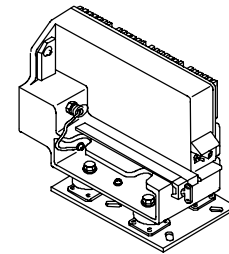

MOUNTING BASE,  
ELECTRICAL EQUIPMENT  
(PA MOUNT)  
MT-6353/VRC

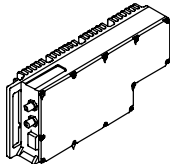

AMPLIFIER, RADIO  
FREQUENCY (PA)  
AM-7238 SERIES

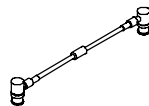

CABLE ASSEMBLY,  
RADIO FREQUENCY  
CG-3856/VRC

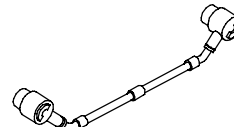

CABLE ASSEMBLY,  
POWER, ELECTRICAL  
CX-13303/VRC

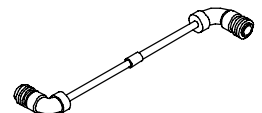

CABLE ASSEMBLY,  
SPECIAL PURPOSE,  
ELECTRICAL  
CX-13291/VRC





**1.2. CONSOLIDATED INDEX OF ARMY PUBLICATIONS AND BLANK FORMS.**

Refer to the latest issues of DA Pam 25-30 to determine whether there are new editions, changes or additional publications pertaining to the equipment.

**1.3. REPORTING EQUIPMENT IMPROVEMENT RECOMMENDATIONS (EIR).**

If your series of radio sets needs improvement, let us know. Send us an EIR. You, the user, are the only one who can tell us what you don't like about the design. Put it on an SF 368 (Product Quality Deficiency Report).  
 Mail  
 it to: US Army CECOM, ATTN: AMSEL-LC-E-ED, Fort Monmouth, NJ 07703-5006. We'll send you a reply.

**1.4. MAINTENANCE FORMS, RECORDS, AND REPORTS.**

- a. **Reports of Maintenance and Unsatisfactory Equipment.** Department of the Army forms and procedures used for equipment maintenance will be those prescribed by DA Pam 750-8 as contained in Maintenance Management Update.
- b. **Reporting of Item and Packing Discrepancies.** Fill out and forward SF 364 (Report of Discrepancy (ROD)) as prescribed in AR 735-11-2/DLAR 4140.55/SECNAVIST 4355.18/AFR 400-54/MCO 4430.3J.
- c. **Transportation Discrepancy Report (TDR) (DD 361).** Fill out and forward Transportation Discrepancy Report (TDR) (DD 361) as prescribed by Federal Property Management Regulation (FPMR), Code of Federal Regulations, Title 41, Chapter 101, Public Contracts and Property Management.

**1.5. DESTRUCTION OF ARMY ELECTRONICS MATERIEL.**

Destruction of Army electronics materiel to prevent enemy use shall be in accordance with TM 750-244-2.

**1.6. PREPARATION FOR STORAGE OR SHIPMENT.**

Before placing equipment in administrative storage, Operational Checks will be performed and necessary repairs made. Remove batteries prior to storage. When removing equipment from administrative storage, an Operational Check will be performed to assure operational readiness.

**1.7. NOMENCLATURE CROSS-REFERENCE LIST.**

This list contains common names used in this manual in place of the official nomenclature.

COMMON NAME:	NOMENCLATURE:
Audio/data cable	Cable Assembly, SP, Electrical (W4)
Battery	Battery, Non – Rechargeable BA – 5590/U Battery, Rechargeable BB – 590/U Battery, Rechargeable BB – 390
Battery box	Battery Box CY-8523A/PRC, CY-8523B/PRC and CY-8523C/PRC
CDU vehicular adapter cable	Cable Assembly, SP, Electrical – CDU
Control-monitor	Control-Monitor C-11291/VRC, C-11291A/VRC
Fill device	Automated Net Control Device (ANCD), AN/CYZ-10 Computer System, Digital, AN/PYQ-10 (Simple Key Loader)

## 1.7. NOMENCLATURE CROSS-REFERENCE LIST. Continued

COMMON NAME:	NOMENCLATURE:
GPS fill cable	Cable Assembly, SP, Electrical- GPS Fill (W20)
Handset	Handset, H-250/U
HRCRD	Handheld Remote Control Radio Device, C-12493/U
Hold-up battery (HUB)	Battery, Non-Rechargeable, BA-5372/U
HUB insert	Hold-up Battery Insert (for RT-1523E/F only)
Intercom cable	CX-13300/VRC
Loudspeaker	Loudspeaker, LS-454/U Loudspeaker, LS-671/VRC
Loudspeaker cable	CX-13292/VRC, used with LS-671/VRC
Manpack antenna	Antenna, Manpack, AS-3683/PRC Antenna, Manpack, AS-4266A/PRC
Mounting base (MB)	Mounting Base, Electrical Equipment MT-6352/VRC, MT-6352A/VRC
Power amplifier (PA)	Amplifier, Radio Frequency AM-7238 Series
PA mount	Mounting Base, Electrical Equipment MT-6353/VRC
Power cable	Any power cable connected to mounting base connector J1 or J2
Power Supply Adapter (PSA)	Adapter, Power Supply MX-12275/VRC
Radio	Radio Sets
Remote control unit (RCU)	Control, Receiver-Transmitter, C-11561(C)/U
RF cable	Cable Assembly, RF
RT*	Receiver-Transmitter, Radio RT-1523 Series,
Single ASIP Radio Mount (SARM)	Radio system containing an Adapter, Power Supply MX-12275/VRC
Splitter cable	CX-13417/VRC
Survivable Low Profile Antenna (SLPA)	Antenna, Vehicular AS-3916/VRC
Test set	Test Set, Radio AN/PRM-34
Vehicular amplifier-adapter (VAA)	Amplifier-Adapter, Vehicular, AM-7239 Series,
Vehicular antenna	Antenna, Vehicular AS-3900/VRC, AS-3900A/VRC, or AS-3916/VRC

\* RT-A is in the lower position of VAA; RT-B is in upper position of VAA.

## SECTION II

### PRINCIPLES OF OPERATION

#### 1.8. GENERAL.

This section covers the principles of operation for the RT-1523 series of radio sets and ancillary equipment.

#### NOTE

RT -A designates bottom RT in VAA, and RT -B designates top RT in VAA.

#### 1.9. DC POWER INPUT AND DISTRIBUTION.

- a. Battery Power for Manpack Radio.** The primary battery, BA-5590/U (non-rechargeable), BB-590/U (NiCad, rechargeable), or BB-390 (Nickel Metal Hydride, rechargeable), is used to provide power. These batteries are used to provide 10.5 to 15.5 V dc through the system connector (P1) on the back of the RT. Battery box CY-8523 series is provided to hold the battery to the RT.
- b. Vehicular Power.** The vehicular battery provides an input voltage that may vary from 22 to 32 V dc. The battery is connected to the mounting base by a power cable. In some vehicles, the cable is connected to a terminal block which is connected to the battery.
- c. Power Distribution in Mounting Base (MB) MT-6352 Series.** The 22 to 32 V dc enters the MB on pin B of connector J1 and is wired to pin B of J2, J3, and J4. Connector J2 is the power out connector and provides 22 to 32 V dc to either a PA mount or other peripheral equipment. Connector J3 or J4 supplies 22 to 32 V dc to be used by the LS-671 loudspeaker and intercom.

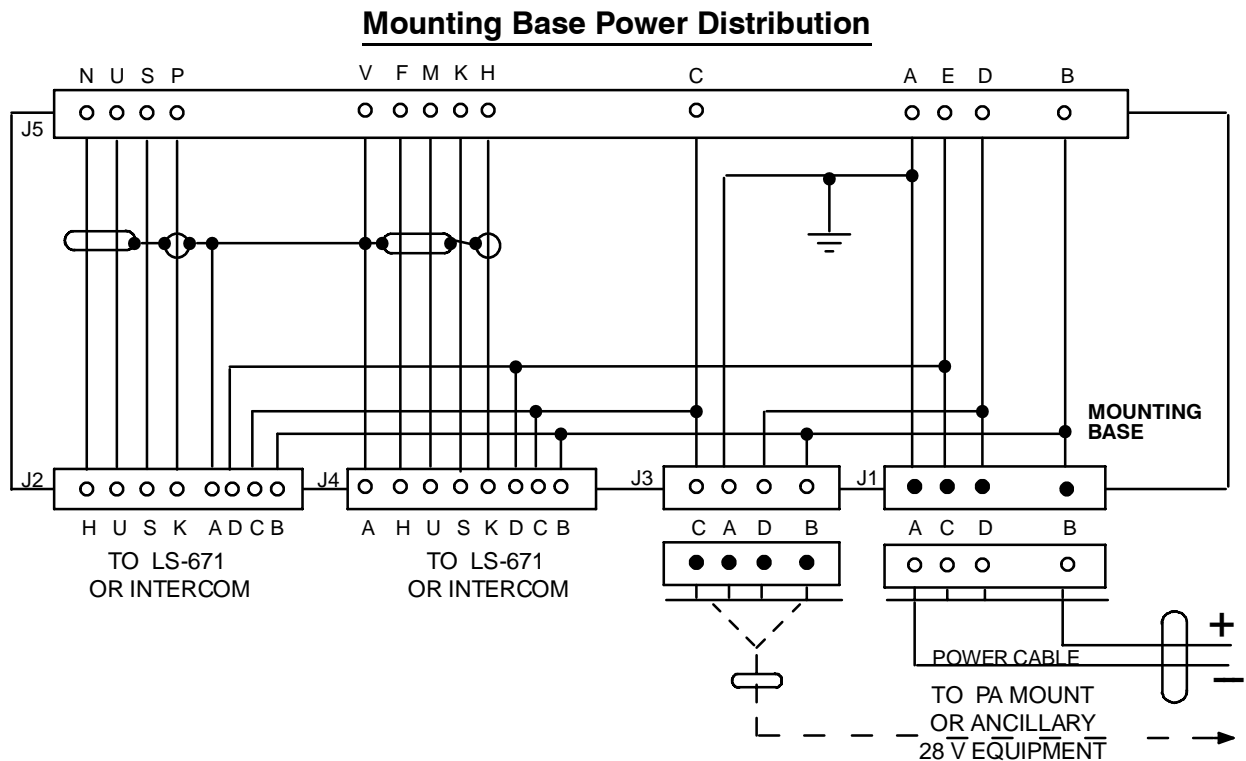

**1.9. DC POWER INPUT AND DISTRIBUTION.** Continued

- d. **Power Distribution in Vehicular Amplifier-Adapter (VAA), AM-7239 Series.** The 22 to 32 V dc from J5, pin B, of the MB, enters the VAA through P1, pin B. P1, pin B is connected to CB1, which provides over-current protection for the power supply. In the AM-7239 version of VAA, a shorting bar is used on TB2 to bypass the contacts of relay K1 for LOCAL power control. The shorting bar is removed for REMOTE power control. In the AM-7239A, a shorting jumper is moved for LOCAL or REMOTE operation. In the AM-7239B,C,D and E, a switch is used for LOCAL or REMOTE operation.

DS1 will light at the AM-7239 if power is present. DS1 will light at AM-7239A if power is present at output contact of relay K1. DS1 will light at AM-7239B,C, and E if power is present on 13 V dc line.

In the AM-7239E, transient protection is provided by the Transient Protect CCA (A3A1). The transient protection circuit controls the gates of parallel field effect transistors (FET) Q7, Q8 which are in series between the power input and the input to power supply A1.

**AM-7239 Power Distribution**

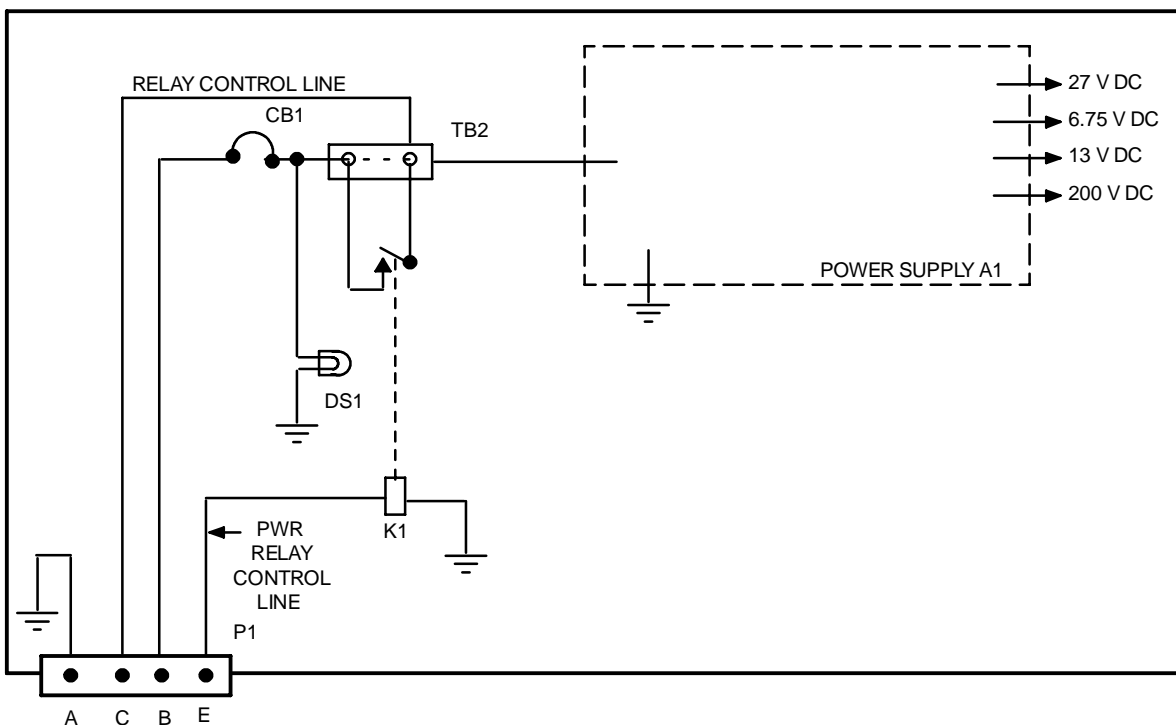

1.9. DC POWER INPUT AND DISTRIBUTION. Continued

**AM-7239A/D Power Distribution**

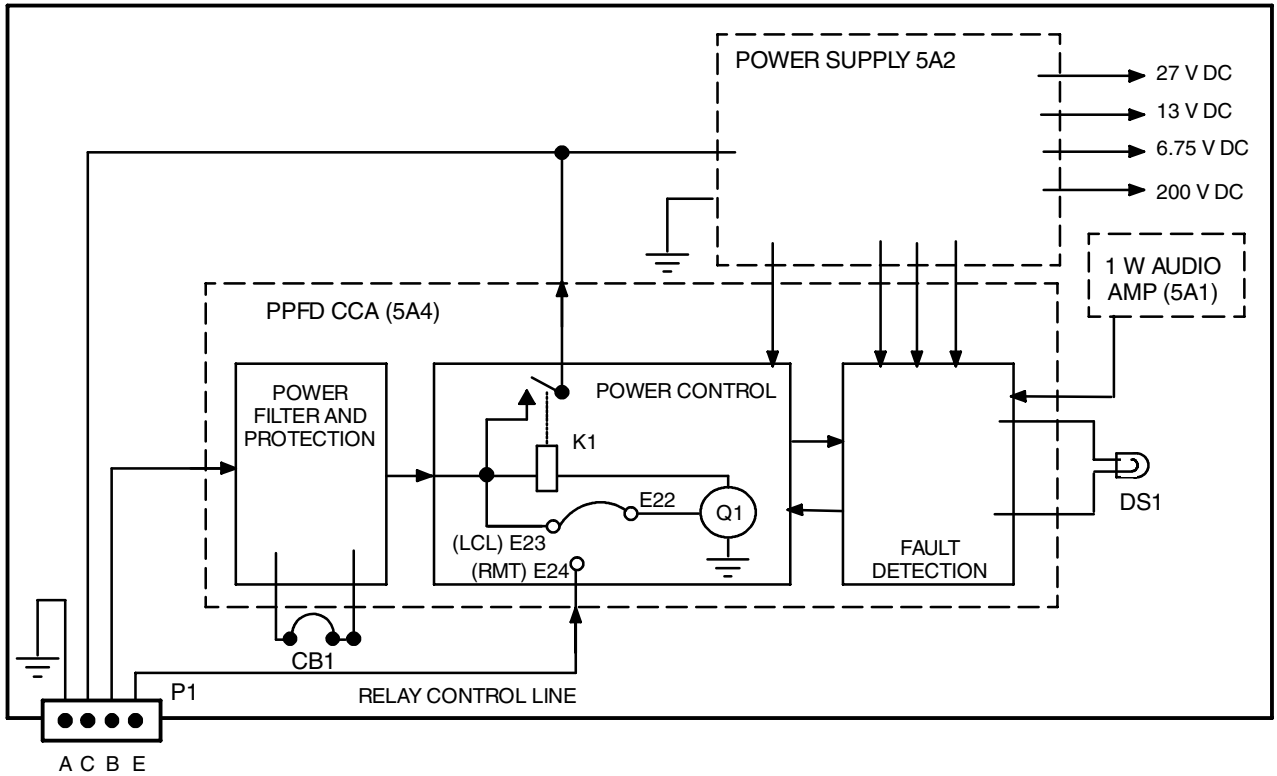

**AM-7239B/C Power Distribution**

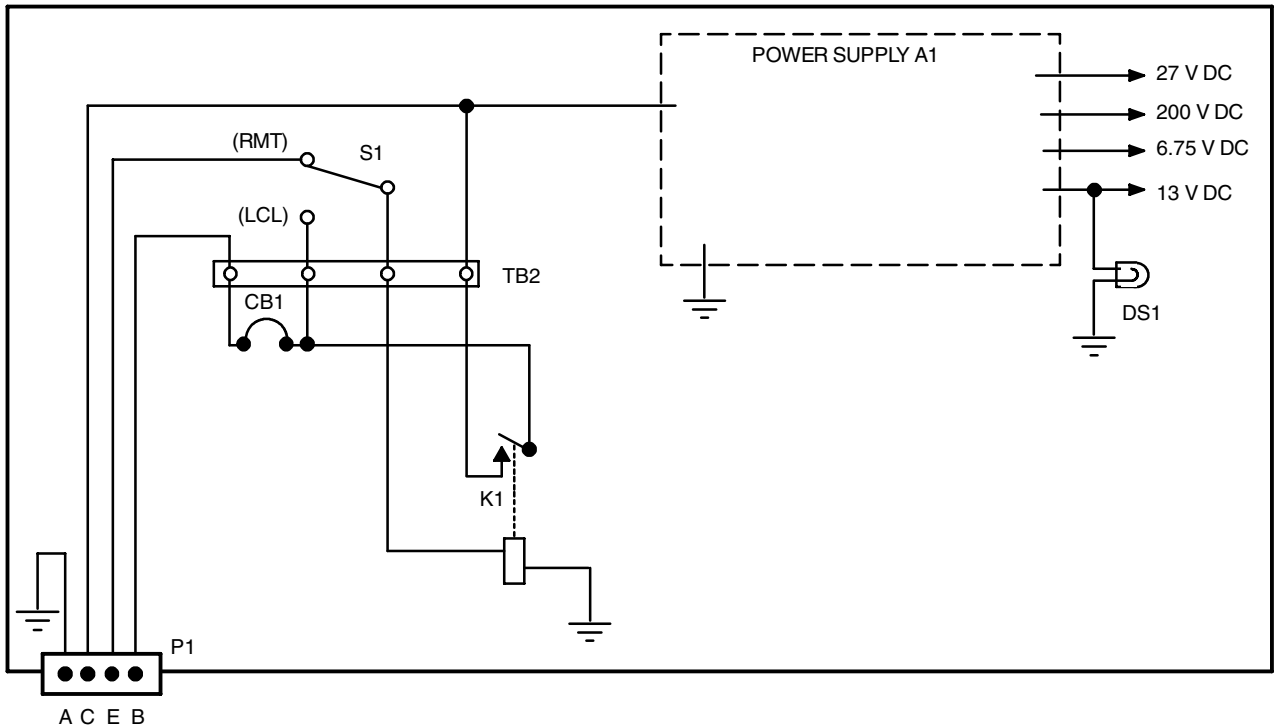

1.9. DC POWER INPUT AND DISTRIBUTION. Continued

**AM-7239E Power Distribution**

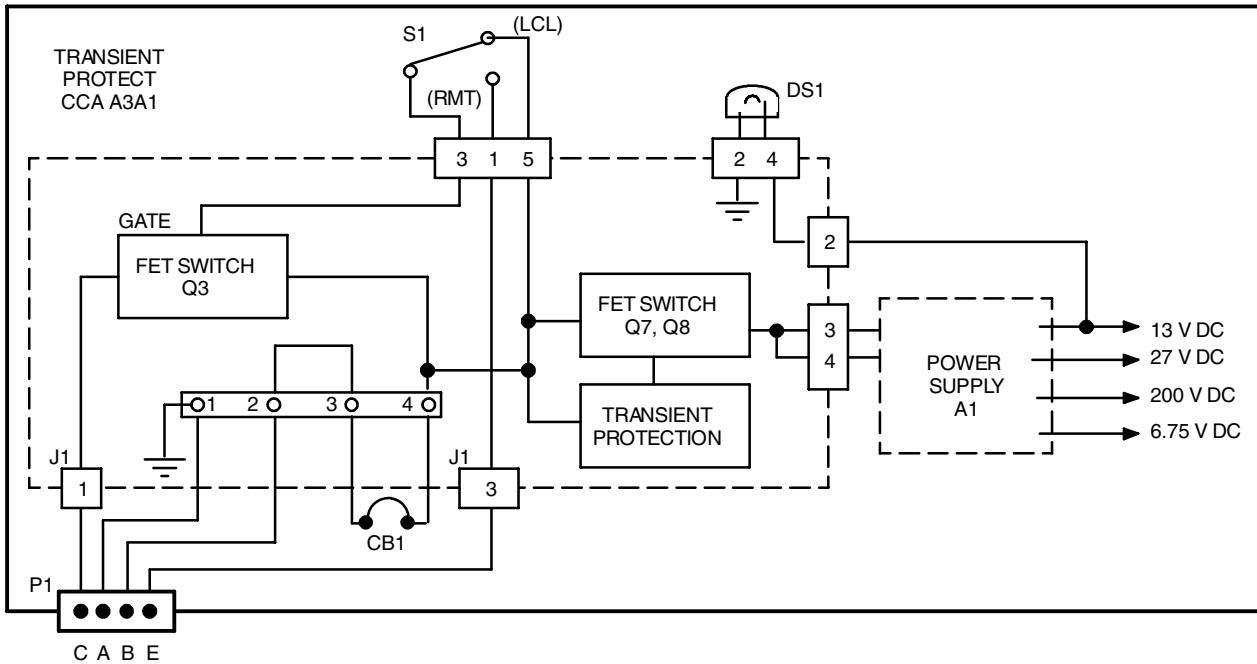

e. **REMOTE/LOCAL Power Control Operation.** There are six models of VAA: AM-7239 SERIES. The principal difference among these models is in the method of selecting LOCAL and REMOTE operation. The AM-7239 uses a shorting bar which is changed by removing a cover panel on the side of the VAA. The AM-7239A uses a shorting jumper, also located behind a cover panel. The AM-7239B,C and D uses a Local/Remote switch which is visible to the left of the RT-B J7 system connector. The AM-7239E uses a Local/Remote switch which is to the right of DS1. The following illustrations demonstrate these differences.

(1) **Placing VAA into Local or Remote Mode (AM-7239):**

MAINTENANCE REQUIREMENT:	ACTIONS:
(1) Shorting bar (3)  <b>NOTE:</b> If you have an LS-671 or VIC installed, place the shorting bar in REMOTE position.	(1) Remove cover (2). (2) Position shorting bar (3) on terminal block as required. (3) Install cover (2).

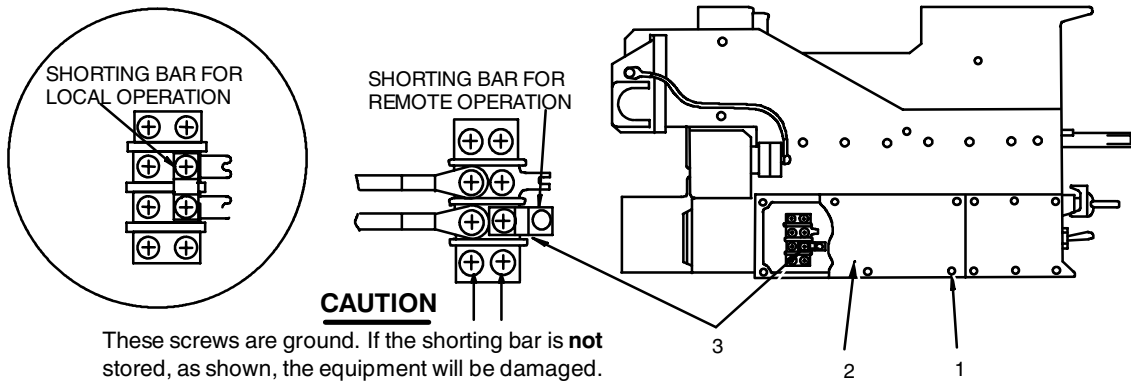

1.9. DC POWER INPUT AND DISTRIBUTION. Continued

(2) Placing VAA into Local or Remote Mode (AM-7239A):

MAINTENANCE REQUIREMENT:	ACTIONS:
(1) LOCAL/REMOTE Jumper  <b>NOTE:</b> If you have an LS-671 or VIC installed, place jumper in REMOTE position.	(1) Remove cover. (2) Place jumper in LOCAL (E23), position if there is no LS-671 or VIC present. (3) Place jumper in REMOTE (E24), position if there is an LS-671 or VIC installed. (4) Install cover.

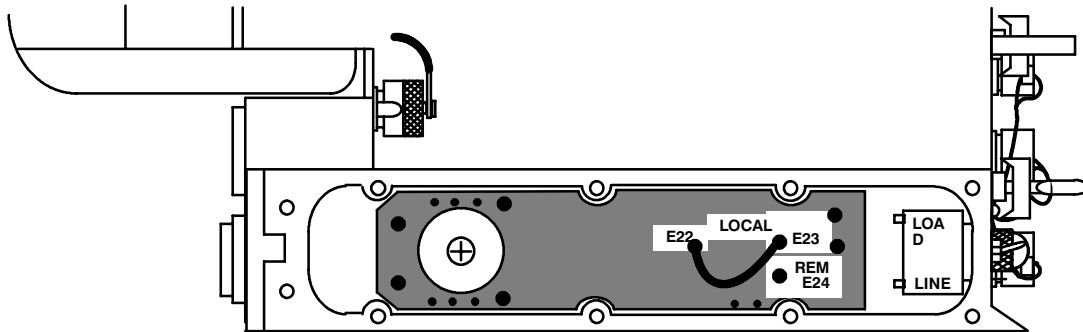

(3) Placing VAA into Local or Remote Mode (AM-7239B, C, D, E):

MAINTENANCE REQUIREMENT:	ACTIONS:
(1) REMOTE/LOCAL switch S1  <b>NOTE:</b> If you have an LS-671 or VIC installed, place switch in REMOTE position.	(1) Set switch to LOCAL, if there is no LS-671 or VIC installed. (2) Set switch to REMOTE, if there is an LS-671 or VIC installed.

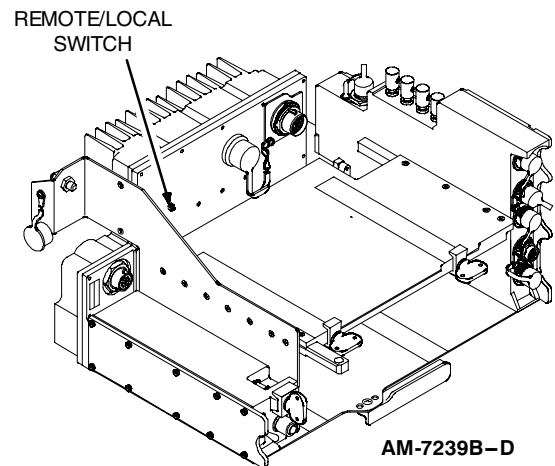
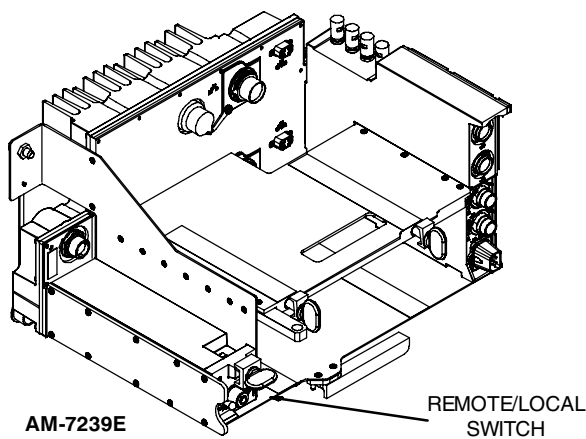

1.9. DC POWER INPUT AND DISTRIBUTION. Continued

f. **Power Supply Module.** The 22 to 32 V dc is applied to power supply A1. This power supply is a dc-to-dc converter which takes the 22 to 32 V dc and produces the following voltages:

- 6.5 to 7.25 V dc
- 12.6 to 13.4 V dc
- 180.0 to 220.0 V dc

These voltages are used by RT-A, RT-B, RCU-A, RCU-B, control-monitor, and power amplifier installed on the VAA.

g. **Power Distribution in Power Amplifier Mount (PA mount) MT-6353.** The 22 to 32 V dc enters the PA mount through J1, pin B from J2, pin B of the MB. The 22 to 32 V dc used to energize the K1 relay enters the PA mount through J1, pin C from J2, pin C of the MB. When CB1 of the VAA is set to ON, 22 to 32 V dc will be applied to J1, pin C of the PA mount causing the K1 relay to energize. This allows the 22 to 32 V dc at J1, pin B to be applied to power supply A1 of the PA mount when CB1 is set to ON. This, in turn, allows DS1 to light.

**PA Mount MT-6353 Power Distribution**

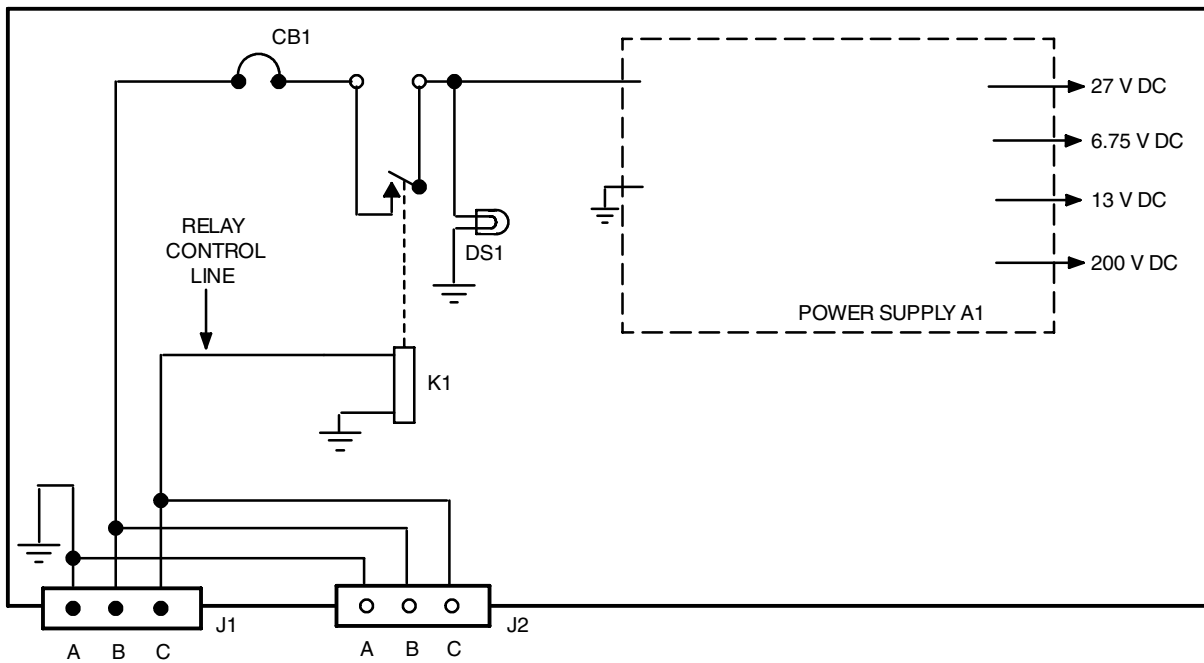

h. **Power Distribution in the Loudspeaker-Control Unit LS-671.** The loudspeaker-control unit LS-671 controls the power to the radio with its ON/OFF switch if the VAA is set to REMOTE.

The primary power enters the MB at connector J1, pin B. From here it is distributed to connectors J3 and J4, pin B. A loudspeaker cable carries the dc to the LS-671 system connector J1, pin B. If the loudspeaker ON/OFF switch is in the ON position, the dc power from pin B is connected to pin D. The loudspeaker cable carries the dc back to the MB connectors J3 and J4, pin D. Pin D of the MB is connected to the MB system connector J5, pin E. This is a direct connection to VAA system connector P1, pin E.

Dc power on P1, pin E of the VAA energizes relay K1 allowing dc power to exit on pin C. Pin C of the MB distributes the dc power to connectors J3 and J4. The loudspeaker cable carries the dc through LS-671 system connector J1, pin C, to power the audio amplifier.



## 1.10. RECEIVE SIGNAL PATH.

- a. **RF Signal.** The RF signal is picked up by an antenna.

Manpack antennas connect directly to the RT ANT connector J1. The RT contains an impedance network that matches the RT to the AS-3683 antenna. The AS-4266A contains its own matching network.

Vehicular antennas use an RF cable to transfer RF energy to the RT. The antenna base and RT have impedance networks to match the 50 ohm RF cable.

- b. **Analog Voice Receive Signals.** RT voice signals are limited to the bandwidth of 300 Hz to 3 kHz. The analog signal is amplified and sent to the AUD/DATA, AUD/FILL, and rear system connector P1.

### **AM-7239, AM-7239A, AM-7239B only**

Audio from AUD/DATA is taken by the W4 cable to the VAA. In the VAA, audio is amplified and sent to connector J6 (SPKR) and VAA system connector P1 as variable audio. The RT-A and RT-B audio are summed in the VAA for the speaker connector J6. A muting line is provided at MB connector J2 for external muting of RT-A or RT-B audio at J6.

From RT -A or RT -B rear system connector P1, audio is sent to the VAA system connector P1 as fixed level audio.

High level audio lines are used by the intercom. The amplification of the audio for these lines is provided by the radio system. For AM-7239, AM-7239A, and AM-7239B this is the amplified video mentioned in the box above. For other VAAs this is from the fixed level audio at RT P1, amplified by the VAA. The "A" audio enters the MB system connector J5, pin F and exits at connector J3, pin H. The "B" audio enters MB system connector J5, pin N and exits at connector J4, pin H.

Low level audio lines are used by the intercom and the LS-671. The amplification of this audio is provided by the peripheral equipment. The audio is from RT P1. The "A" audio enters the MB system connector J5, pin H and exits at connector J3, pin K. The "B" audio enters the MB system connector J5, pin P and exits at connector J4, pin K. Detailed information on the receive paths of the intercom and LS-671 is provided in TM 20 -2.

- c. **Analog Digital (AD1 or TF) Signals.** Analog data can be processed using either AD1 or TF. When the RT is set to AD1, the analog data signal follows the audio receive path. When TF is used, the analog data is converted into 16 kbps digital data by the transmitter. The receiver converts it back into analog data.
- d. **Squelch Circuit.** A tone squelch circuit is used to prevent the reception of noise when a signal is not being received. This allows the RT-1523 series and AN/VRC-12 (NATO FM radio) series radios to communicate with each other.

## 1.11. TRANSMIT SIGNAL PATH.

- a. **Keying Circuit.** The transmitter is "keyed" when the handset PTT switch is pressed. This places a ground on the handset audio connector pin C. For the AM-7239C and later VAAs and all manpack radios, the handset is connected to the RT-A or RT-B AUD/DATA pin C. For AM-7239B and earlier, the handset is connected to the VAA and is sent to the RT AUD/DATA connector, pin C, via the W4 cable.

A PTT ground can also be generated by the LS-671. MB J3 controls RT -A by passing the ground from pin S to VAA P1, pin K. For AM-7239C and later VAAs the ground is routed to RT system connector P1, pin S on RT-a. For AM-7239B and earlier, VAA P1, pin K is connected to the 1 watt audio amplifier in the VAA. The 1 watt audio amplifier places the ground on pin C of AUD/DATA connector J5. The ground is sent through the W4 cable, pin C, and then to the RT -A AUD/DATA, pin C.

**1.11. TRANSMIT SIGNAL PATH.** Continued

MB J4 controls RT -B by passing the ground from pin S to VAA P1, pin S. For AM-7239C and later VAAs the ground is routed to RT system connector P1, pin S on RT-B. For AM-7239B and earlier, VAA P1, pin S is connected to the 1 watt audio amplifier in the VAA. The 1 watt audio amplifier places the ground on pin C of AUD/DATA. The ground is sent through the W4 cable, pin C, then to RT -B AUD/DATA, pin C.

When the LS-671 is installed, the connected handset will provide the necessary ground to transmit. Either RT -A or RT -B will be controlled depending on whether the LS-671 is connected to MB J3 or J4. The connection is made by a loudspeaker cable (CX-13292).

- b. Analog Voice Transmit Signals.** Audio signals are generated in the handset when the PTT switch is pressed. These signals are on pin D of the handset and are passed directly to manpack and AM-7239C and later configuration RTs, or to VAA J2 or J3 for AM-7239B or earlier configurations. For AM-7239B and earlier configurations, VAA J2 and J3 are wired in parallel to connectors J4 and J5, and connect to the RT s via W4 cables.

Audio signals are also generated at the LS-671. Cables pass these signals to MB J3 or J4, pin U.

**AM-7239B and earlier**

J3 audio enters the VAA system connector P1, pin M. The signal is present at the VAA J3, pin D and J5, pin D. Connector J3 is where the RT-A handset is placed. Connector J5 is connected to the RT-A AUD/DATA, pin D by a W4 cable. The audio is then processed and transmitted.

J4 audio enters the VAA system connector P1, pin U. The signal is present at the VAA J2, pin D and J4, pin D. Connector J2 is where the RT-B handset is placed. Connector J4 is connected to the RT-B AUD/DATA, pin D by a W4 cable. The audio is then processed and transmitted.

**AM-7239C and later**

J3 audio enters the VAA system connector P1, pin M. J4 audio enters the VAA system connector P1, pin U. The audio is routed through the VAA to RT-A and RT-B system connectors P1, pin E. The audio is then processed and transmitted.

- c. Whisper (WHSP) Control.** The RT whisper mode is selected, by pulling out the RT WHSP control for RT-1523D and earlier, or by the RT menu for RT-1523E/F. When whisper mode is selected, an internal audio preamplifier is turned on. The microphone circuit now additionally amplifies the whispered voice. This allows the use of the radio in situations where the user does not wish to be overheard.
- d. Analog Data Modulation.** Data devices are connected in place of the handset on the VAA (AM-7239B or earlier) or RT (AM-7239C or later). The handset is then connected to the RT AUD/FILL. A wide range of data signals can be transmitted. The data is frequency modulated on the RF carrier and transmitted. In AD1, all incoming FSK signals are treated the same as voice signals. In TF (TACFIRE) the FSK tones are changed to a 16 kbps signal.

For RT-1523B and earlier, the RT needs a ground applied to pin F of the AUD/DATA connector for TF mode. The ground informs the RT to go to the analog data mode. Pin F is grounded by an FSK detector circuit in the VAA for the vehicular radio. Pin F is grounded by an adapter cable (CX-13308/VRC) for the manpack radio.

- e. Digital Data Modulation.** Data devices are connected to RT AUD/DATA. The handset is then connected to RT AUD/FILL. A number of data rates are available for selection; 600 bps, 1.2 kbps, 2.4 kbps, 4.8 kbps, and 16 kbps (RT-1523A/B ). For RT-1523C/D/E the following data rates are available: 600,1200, 2400, 4800, 16000, 1200N, 2400N, 4800N, 9600N, PCKT, and RS-232. When low data rates are used, the error correction coding allows a greater communication range and increased message accuracy.

### 1.11. TRANSMIT SIGNAL PATH. Continued

- f. **RF Forward Power.** The RT has four RF power settings L, M, HI, and PA. See Equipment Data for power levels. When the AS-3683 manpack antenna is used with the RT, an internal impedance matching network matches the antenna impedance to that of the RT. The vehicular antenna and the RT have impedance matching networks to match the 50 ohm RF cable.
- g. **RF Reverse Power Protection.** No damage shall occur when transmitting into a VSWR between 1 and infinity. The RT will not be harmed if it is keyed without an antenna connected. When the VSWR circuit detects a VSWR greater than 5:1, it interrupts (disables) the handset sidetone.

### 1.12. FREQUENCY HOPPING OPERATION.

- a. **General.** The RT-1523 series contains circuitry which provides encryption and decryption for Communication Security (COMSEC). Transmission security is provided by frequency hopping, with the frequency determined by the variables, including time, which are loaded into the RT. When all data is loaded into the RT, the radio can change frequencies (HOP) more than one hundred times a second.
- b. **Frequency Hopping Variables.** The process of frequency hopping requires four data elements or variables. They are: (1) a hopset, which is a group of frequencies (30 to 87.975 MHz) that the radio uses; (2) a TRANSEC (TSK) key, which is used in selecting the frequency hopping sequence; (3) a NET ID, a three digit number from 000 to 999 that fixes the hopping start point; and (4) sync time, which must be within +/– 4 seconds of each other.
- c. **RF Circuitry.** The RT uses the same RF circuits for both Single Channel (SC), and Frequency Hopping (FH). In the FH mode, the intelligence is converted into digital data of 16 kbps. The digital data is then distributed across the frequencies of the hopset. The distributed signal is then processed by the RF amplifiers and spread over a number of RF frequencies prior to being transmitted. The receiver, however, must be able to track with the transmitter in order to decipher the digital message of the frequency hopping transmitter. The transmitter provides the receiver with certain signals that enable the receiver and transmitter to synchronize with each other. With the receiver and transmitter in sync, the receiver converts the message back to either voice or data.

### 1.13. TIME MANAGEMENT.

- a. **General.** Before the RT-1523 series radio can operate in a frequency hopping net, it must have sync time entered. All RTs in a net must have the same net ID, TRANSEC key, hopset, and FH sync time within +/– 4 seconds in order to communicate with each other. If the sync times are different, the RTs cannot communicate in FH mode.
- b. **Timing Restrictions.** There are different operating time restrictions for the RT. The time restrictions apply to different operating modes as listed below.

Active in-net usage	+ 4 seconds
Passive late net entry	+ 1 minute
Use of ERF capability	+ 1 hour (RT-1523)
	100 days (RT-1523A/1523B/1523C/1523D/1523E and 1523F)

- c. **Base FH Sync Time.** If the FH sync time is entered with the front panel keyboard, all clocks of the RT are set to the base FH sync time entered through the keyboard. If the FH sync time is entered by ERF, the following will occur:

**1.13. TIME MANAGEMENT.** Continued

**When nets are inactive (net opening):**

**COLD START**

FH sync time transmitted by ERF becomes the new base FH sync time at the receiving radio.

All clocks of the receiving RT are set to the new base FH sync time.

**HOT START**

FH sync time is entered manually via keypad or electronically by connection to an SKL, ANCD, EGR, or PLGR.

**When nets are active (net updates):**

FH sync time transmitted by ERF replaces the FH sync time of the channel in which the ERF is stored.

The base FH sync time of the receiving RT is not altered.

**1.14. RT MAIN PANEL DISPLAYS.**

**RT-1523 through RT-1523D**

- a. **General.** There are three main panel displays.
- b. **SIG Display.** In the receive mode, the SIG display reads the relative strength of the received signal. The stronger the RF signal, the higher the display will read. When transmitting, the SIG display indicates the RF power output. In LO, the display lights bars 1-2, in M, bars 3-4, and in HI, bars 5-6. In PA, all 6-7 bars of the SIG display light.
- c. **RT Display.** This display shows the operator indications such as: the single channel operating frequency, net ID, COMSEC key, data rate, battery life indication, and sync time. Some versions of the RT indicate traffic on the net by placing an M in the display. When a FAIL message is displayed, there is a failure in the RT.
- d. **HUB Display.** The HUB is used to retain internal memory when the RT is in standby operation and when the main power or main battery fails or is removed. The HUB display flashes on and off when HUB power is low and remains on continuously when the HUB is spent or removed.

**RT-1523E/F**

- e. **General.** The RT-1523E/F has a single front panel LCD display. It has a backlight which can be turned on and off from the keypad. It is organized in three regions.
- f. **Right Side.** At the right side are two indicators: the top one is a dot which indicates power is present and the bottom one is "WHSP" when the whisper mode is activated.
- g. **Top Row.** There are five indicator across the top from left to right: a vertical bargraph signal strength meter, a transmit power level setting indicator, a FH mode indicator, a channel indicator and a COMSEC mode indicator.
- h. **Bottom Row.** A second row consists of a 13-character free-text region which displays operator indications such as: the single channel operating frequency, net ID, COMSEC key, data rate, battery life indicator, and sync time. It also displays a menu for setting volume, channel, power level, FH mode, and COMSEC mode.

**1.15. RT SELF-TEST (RT-1523 THROUGH RT-1523D).**

- a. **RT Self-Test.** The RT self-test is selected by setting the FCTN switch to the TST position. The displays and audio should be as shown below. Some versions of the RT will show “FAIL 5” if self-test is run with COMSEC set to PT. Setting COMSEC to CT should result in a display of “GOOD”.

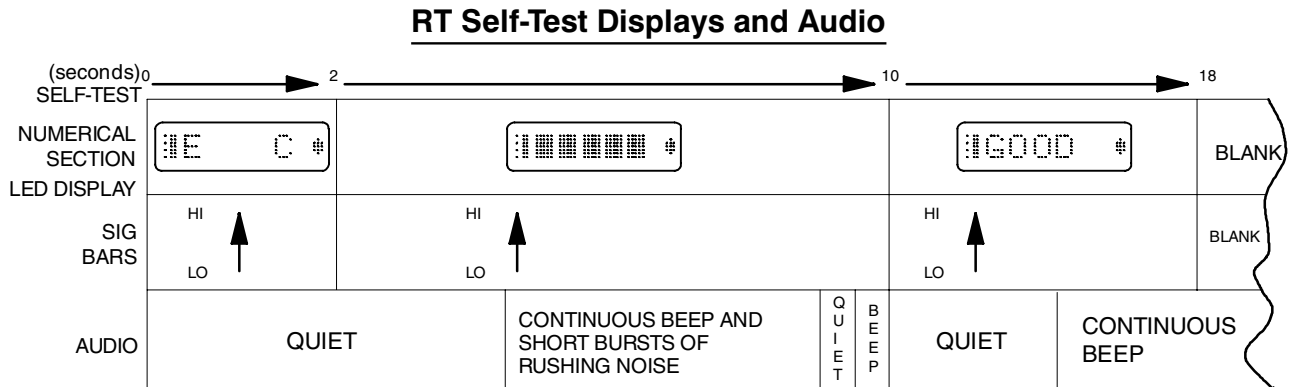

The RT display is the first section tested in self-test. The first display is “E C.” The letter “E” shows that the ECCM module is present. The letter “C” shows that the COMSEC module is present. If either module is absent, its letter in the display is replaced by a dash (–). The next display checks the display elements. All the dots in each digit of the display are lit. The SIG display bars are lit in sequence. The HUB display is also lit. After the display is checked, the RT continues its self-test. The receive path is checked at eight frequencies in SC mode and two frequencies in FH mode. As a result of the receive tests, there are 10 short bursts of unquenched rushing noise which can be heard in the handset. However, because these are so quick and close together, they are difficult to count. At the end of a successful self-test, a beep can be heard in the handset, and the display will read “GOOD”.

- b. **Failure Codes.** If a failure occurs, displays on the RT are interpreted as follows:

- FAIL 1** Internal RT Failure Receive
- FAIL 2** Internal RT Failure Data Rate Module
- FAIL 3** Internal RT Failure ECCM
- FAIL 4** Internal RT Failure Two Wire
- FAIL 5** COMSEC Failure/RT not in CT
- FAIL 6** SNAP Test or Internet Controller/ FHMUX Failure
- FAIL 7** Internal RT Failure Routing Module
- FAIL 8** Internal RT Failure Routing Module

**1.16. RT SELF-TEST (RT-1523E)**

- a. **RT Self-Test.** The RT self-test is divided into two parts: normal user self-test and detailed maintenance self-test. Normal user self-test is initiated by setting the FCTN switch to TST. The detailed maintenance BIT is for Direct Support maintenance only.
- b. **Failure Codes.** The following detailed maintenance failure code is applicable to unit maintenance:
  - FAIL SNAP** SNAP Test or Internet Controller/FHMUX Failure

**1.17. POWER AMPLIFIER.**

- a. **Power Output.** The RF power amplifier is used to extend the transmission range of the RT. The amplified RF output from the PA is a nominal 50 watts, but may vary from 30 to 70 watts. On the RT, in the PA setting, a nominal 4 watts is sent from the RT J1 to the PA J2, then amplified and fed to the antenna via the PA J1. In LO, M, or HI, the output of the RT passes through the PA with no amplification and is output to the antenna.
- b. **RF Power Amplifier Keying Circuit.** The PA is keyed by the RT. When the PTT switch on the handset is pressed, the RT is keyed by placing a ground on pin C of RT AUD/DATA connector. When RF PWR is set to PA and the RT is keyed, 6.75 V dc is placed on RT, P1, pin H. The presence of 6.75 V dc on PA, P1, pin N, keys the PA. A power level signal is generated and sent to the RT signal display. All bars of the signal display light. The RT selects the proper PA filter. Failure of the RT to select the proper band will cause the PA to fail to transmit.
- c. **RF Power Output Filtering.** The PA is a linear amplifier across the frequency band of 30 to 87.975 MHz. The PA has three sets of filters which are selected by the RT.

PA FILTER	OPERATING FREQUENCY (MHZ)	SELECTOR PIN PA CONNECTOR P1
A	30.0 to 43.0	P
B	43.0 to 61.4	R
C	61.4 to 88.0	M

- d. **Voltage Standing Wave Ratio (VSWR).** VSWR is the relative value of forward to reverse power. Any of these faults may cause high reflected power:

- Use of an old VRC -12 antenna or components
- Antenna elements broken, dirty or corroded
- Lower antenna element connector open
- Defective mounting base
- Rusty antenna base mounting bolts
- Loose or missing ground straps
- Wrong type RF cable installed (75 ohm data cable)
- Open RF cable grounds

The PA has a VSWR detector used to measure the reflected voltage. It is compared to the forward voltage to determine the VSWR. When this ratio exceeds 5 : 1, the PA RF output is automatically reduced to a safe level. The RF test set can be used to measure RVS PWR. When the 5 :1 VSWR is reached, RT sidetone is disabled (except with the AM-7238B/VRC RF PA).

- e. **PA Mount.** Some radios use a second PA in a separate mount. The mount is cabled to the VAA, where internal wiring connects the PA mount to RT--B. Cable CX-13303 is used to provide dc power, and CX-13291 is used to pass control signals between the RT and PA.

## SECTION III

### PRINCIPLES OF MAINTENANCE OPERATION

#### 1.18. USE OF MAINTENANCE ALLOCATION CHART (MAC). (See TM 20-2)

The MAC gives you the authority and responsibility for doing maintenance tasks on the RT-1523 series radio and ancillary equipment. There are 12 maintenance functions: inspect, test, service, adjust, aline, calibrate, remove, install, replace, repair, overhaul, and rebuild. You will only do these six: inspect, test, service, remove, install, and replace. These functions are marked with an "O" in the maintenance category column.

#### 1.19. UNSCHEDULED MAINTENANCE.

There is no scheduled (preventive) unit maintenance for the RT-1523 series radio. Maintenance will be performed only when the equipment fails.

#### 1.20. TROUBLESHOOTING.

- a. **Procedure.** The first step is to identify the problem. That is done by performing the prescribed Operational Check, which will locate the fault or specify a Troubleshooting Flowchart to use.
- b. **Flowchart Symbols.** The following standard symbols are used in the flowcharts. Become familiar with these symbols so that you can quickly troubleshoot your equipment. Read the explanation and be familiar with each so that you can readily use the flowcharts.

**Test Procedures Start.** Indicates start of the test procedure.



**Test Procedure Flow Line.** Indicates direction of the procedure flow.



**Test Procedure Instruction.** Gives instructions for doing a specific test.

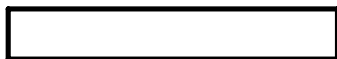

**Decision.** Indicates that a decision must be made (YES or NO) to answer a question about the previous test. Path taken depends on the answer (YES or NO).

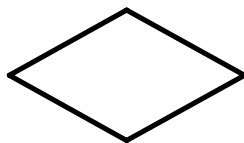

**1.20. TROUBLESHOOTING.** Continued

**Connector.** Directs user to an entry point on another sheet in the same chart. Contains an entry number and sheet number that are the same as the entry number and sheet number found on another sheet in the same chart.



**Notes Column.** Presents critical information. States cautions and warnings that must be observed when doing a test. Has additional data as to what to do or where to go after that step in the testing. Provides references to appropriate circuit diagrams.

**Connector Illustrations.** Front views of connectors are placed accordingly to give the maintainer a visual reference when measuring resistances between pins.

**Helpful Hints.** When taking measurements, remember that a connector's pin numbers are mirror images of those on the connector from which it was removed. Whenever possible, use a chassis ground instead of a pin ground. This will allow you greater flexibility when taking measurements and can prevent shorting the equipment.

**1.21. POST-REPAIR USE OF OPERATIONAL CHECK.**

When the bad LRU has been found, inspected, and replaced, repeat the Operational Check to ensure that the system is in fact operational.

**1.22. TYPICAL SC TEST SETUP.**

For testing RF in SC mode, use the following test setup for short range radios:

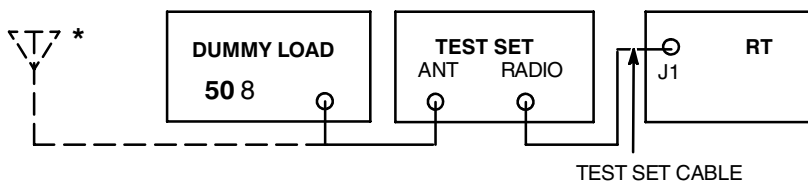

\* INDICATES ANTENNA DISCONNECTED

Use the following test setup for long range radios:

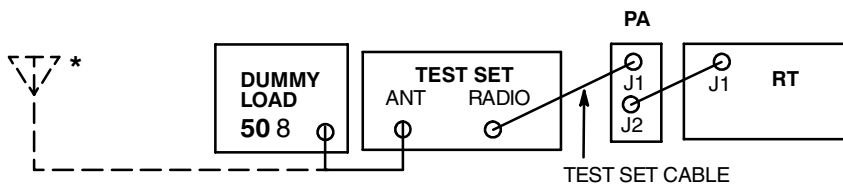

\* INDICATES ANTENNA DISCONNECTED



**SECTION IV**

**PREPARATION FOR STORAGE OR SHIPMENT**

**1.23. GENERAL.**

This section provides steps for packing the RT-1523 series radio. The radio will be properly packed before placing in storage. All PMCS will be done prior to storage.

**CAUTION**

Remove all batteries from equipment before storage or shipment. Ruptured cells will spill corrosive chemicals into electronic circuits.

**1.24. SPECIAL PROCEDURES.**

The RT-1523 series is a controlled cryptographic item (CCI). Remove the HUB battery. Refer to TB 380-40-22 for procedures to prepare for shipment.

There is no need for special preservation, packaging, packing, or marking. Under extreme climatic conditions, corrosion-preventive compounds, moisture barriers, and/or desiccant material may be required.

**1.25. ADMINISTRATIVE STORAGE.**

- a. **General.** Administrative storage is the placement of organic equipment in a limited care and preservation status for short periods of time, reviewed every 6 months to revalidate the requirement.
- b. **Procedures.** Equipment placed in storage must be capable of being restored to a working state within 24 hours. Before storing equipment, apply all mandatory MWOs. Ensure that only equipment rated OPERATIONALLY READY is placed in storage. Refer to AR-750-1.

- (1) Tools and Materials: Tool Kit, Electronic Equipment TK-101/G  
Equipment carton and packing material  
Tape
- (2) Packing: Secure dust covers on component (6) connectors.  
Place component (6) in carton (2).  
Install packing (5).  
Replace manuals (4).  
Close flaps (1, 3) and seal carton with tape.
- (3) Marking: Mark carton with nomenclature, model identification,  
and serial number of radio component.
- (4) Disposition: Place carton in secure storage area.

**1.25. ADMINISTRATIVE STORAGE.** Continued

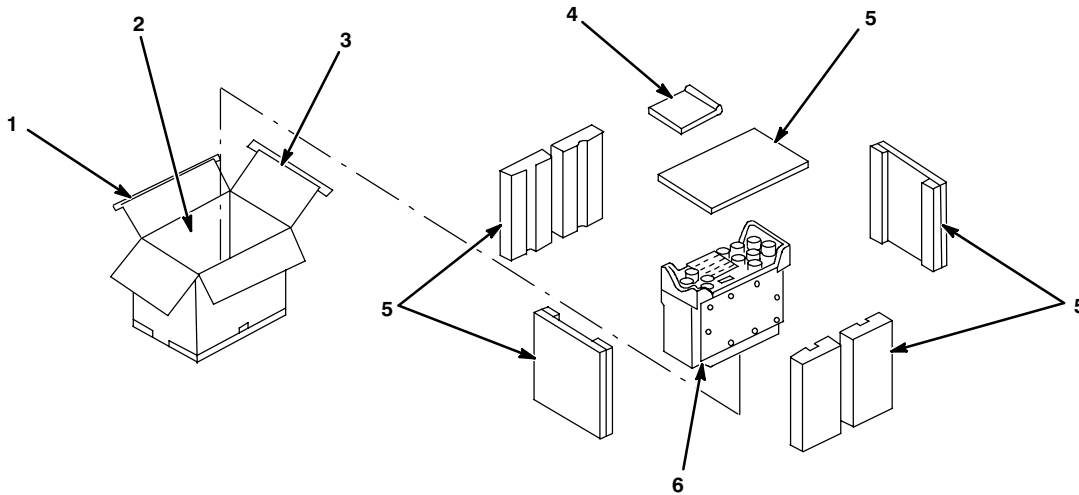

**1.26. INTERMEDIATE STORAGE.**

- a. **General.** Intermediate storage is the placement of organic equipment in storage for less than 180 days.
- b. **Procedures.** Pack equipment for administrative storage.

- (1) Tools and materials: Tool Kit, Electronic Equipment TK-101/G  
Shipping cartons  
Waterproof barrier wrap
- (2) Packing: Place waterproof barrier wrap (1) around equipment carton (2) and seal.  
Place equipment carton in outer carton (3).  
Close flaps and seal.
- (3) Marking: Mark carton with nomenclature, model identification, and serial number of radio component.
- (4) Disposition: Place carton in secure storage area.

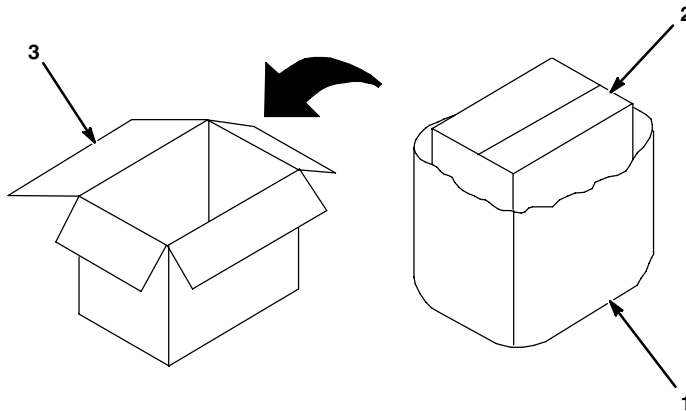

## CHAPTER 2

### MANPACK RADIO

Subject	Para	Page
Assembly Instructions .....	2.1	2-1
Operational Check .....	2.2	2-3
Troubleshooting Flowcharts .....	2.3	2-8.1

#### 2.1. ASSEMBLY INSTRUCTIONS.

The following steps explain how to assemble the manpack radio set.

Tools:

Tool Kit, Electronic Equipment TK-101/G

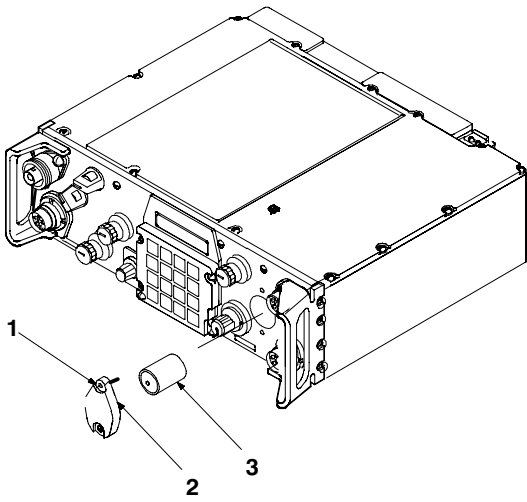
ITEM	ACTION	REMARKS
a. FCTN switch	Set to OFF.	
b. Hold up battery (HUB) cover (2)	Fully loosen two captive screws (1) and remove cover (2).	
c. Hold up battery (3)	If an old battery is present, remove and discard it. Install new battery with NEGATIVE side toward the cover.	RT-1523E/F uses a HUB insert in vehicular configuration only.
		
d. HUB cover (2)	Set in place and tighten two captive screws (1).	<p style="text-align: center;"><b>CAUTION</b></p> <p>Overtightening of HUB cover screws can damage radio front panel.</p>
e. Protective shipping covers	Remove and discard plastic shipping covers on connectors.	

2.1. ASSEMBLY INSTRUCTIONS. Continued

ITEM	ACTION	REMARKS
f. Display cover (16)	Install display cover (16). RT-1523E/F only.	
g. Battery (7)	Position into battery box (6) for all RTs except RT-1523E/F. For RT-1523E/F, remove cover (15) from RT (17). Straighten battery flex (14). Position battery (7) into battery cavity of RT (17). Connect battery flex (14) to battery connector, so bail is laying on top of battery flex. Install cover (15).	
h. Battery box (6)	Set in place and firmly seat on RT (5). Snap four hold-down latches (4) closed.	If the rubber boots on the two-wire interface posts are damaged, replace by pulling the damaged boots off and sliding new boots on.
i. GPS adapter connector (21)	Connect to RT (17) GPS connector (J5). RT-1523E/F with GPS only.	
j. CDU (20)	Connect to RT (16) AUX connector (J6). RT-1523E/F with GPS only.	
k. GPS antenna whip (18)	Lubricate threads with silicone compound: then install on antenna base (12)*. RT-1523E/F with GPS only.	
l. Antenna element (13)	Lubricate threads with silicone compound: then install on GPS antenna whip (18)* or antenna base (12).	
m. Manpack antenna	Screw onto RT ANT connector (11). Hand tighten until snug.	
n. RF cable (19)	Connect one end to GPS adapter connector (21) and the other end to GPS antenna whip (18). RT-1523E/F with GPS only.	

\* If threads do not match, loosen hex nut on bottom of GPS antenna whip (18), and flip top and bottom threaded inserts.

2.1. ASSEMBLY INSTRUCTIONS. Continued

ITEM	ACTION	REMARKS
------	--------	---------

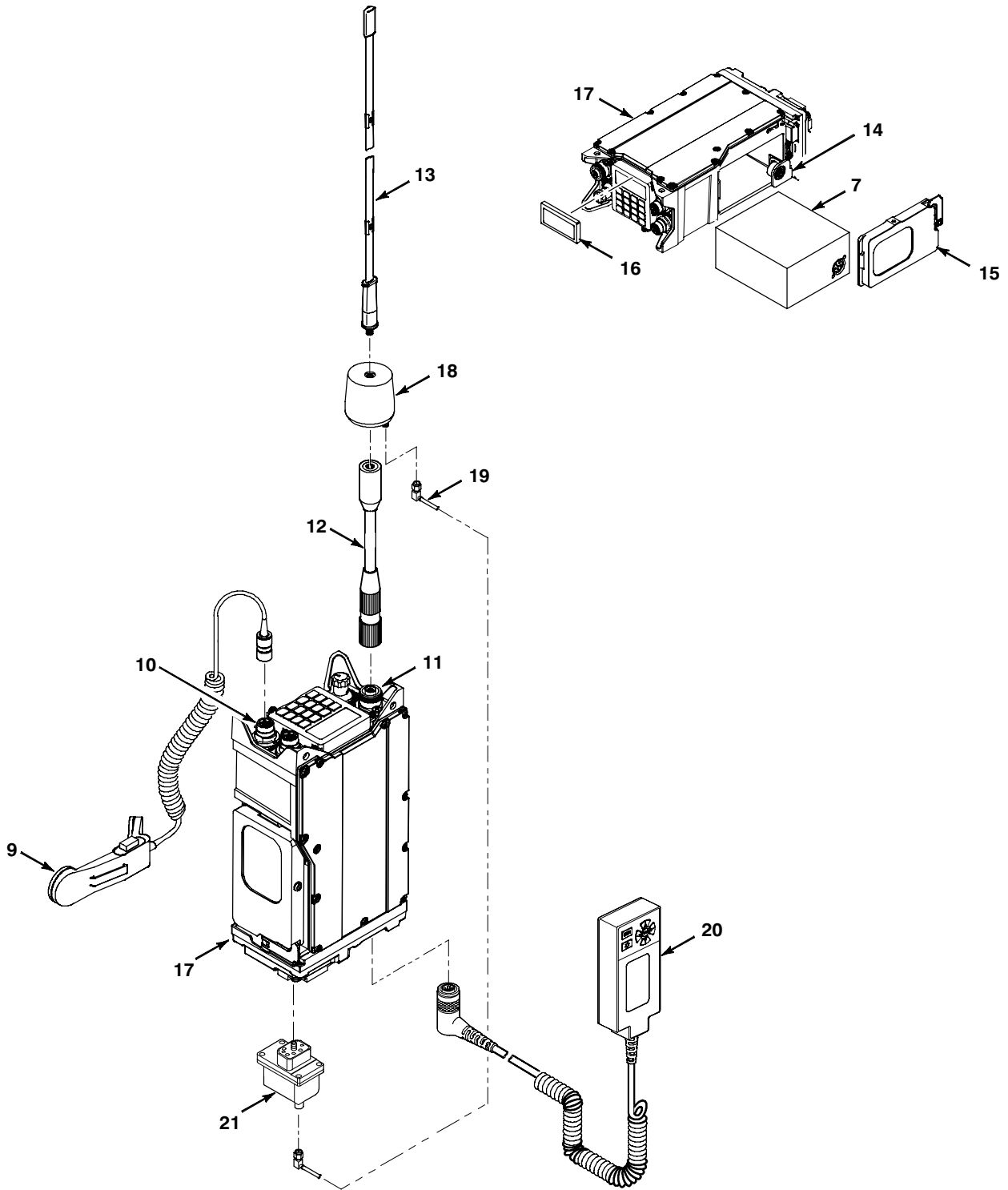

2.1. ASSEMBLY INSTRUCTIONS. Continued

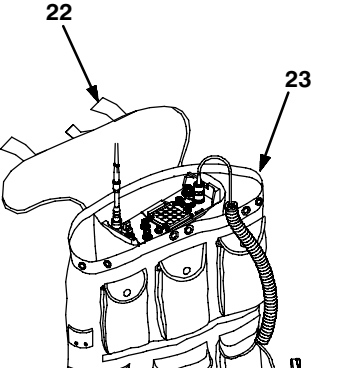
ITEM	ACTION	REMARKS
o. Handset (9)	Lubricate connector O-ring with silicone compound. Connect to RT AUD/DATA connector (10) (J4). On HRCRD handset (8) lubricate both connector O-rings and connect to RT AUD/DATA connector and CY-8523C battery box connector.	
p. RT	Place in backpack sleeve with antenna on the left as shown.	
q. Field pack (23)	Tighten straps (22) to secure RT.	

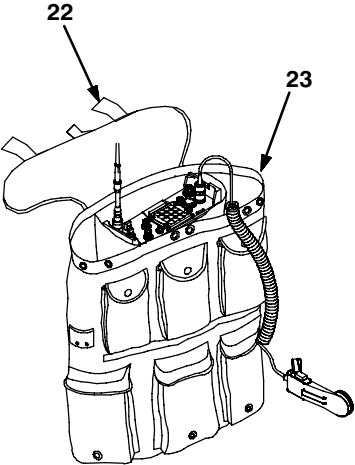

**2.2. OPERATIONAL CHECK.**

The following Operational Check for Manpack Radios, identical in both TM 20–1 and TM 20–3 (Unit Maintenance Handbook), is used to identify what is wrong with a Manpack Radio and determine what corrective actions needs to be taken at Unit Maintenance Level. After corrective action has been taken, this Operational Check is used a second time to verify that the radio is fully operational\*. As a minimum, perform a communication check.

Corrective actions are either specifically stated (for example, Replace RT), or the Unit Maintainer is advised of the most likely symptom to pursue. When the Operational Check identifies a symptom for problem that requires further investigation, the Unit Maintainer is referred to a Troubleshooting Flowchart (TS CHART) which is used to isolate the fault.

In short, use of the Operational Check either identifies the problem and specifies action to be taken, or cites a symptom and refers the Unit Maintainer to a specific Troubleshooting Flowchart. Use of the Operational Check after corrective action has been taken helps to ensure that the Manpack Radio is in fact operational, and such use greatly reduces the possibility of false pulls at Unit Maintenance Level.

\* Operational Check procedures must be performed as shown and in the order given.

**OPERATIONAL CHECK FOR MANPACK RADIOS**

**STEP 1. PREPARATION:**

STEPS TO PERFORM	CHECKS TO MAKE	ACTIONS TO TAKE
1.1 Set RT: FCTN to OFF CHAN to MAN MODE to SC RF PWR to HI VOL to Mid-Range DIM to Full CW COMSEC to Z	N/A N/A N/A N/A N/A N/A N/A	N/A N/A N/A N/A N/A N/A N/A
1.2 Handset, H-250: / HRCRD*** Connect to RT AUD/DATA	Ensure handset is operational	Install known good handset
1.3 Control Display Unit***: Connect to RT-1523E/F AUX connector J6	Ensure CDU is operational	Install known good CDU
1.4 Main Battery	Ensure good power	Install known good battery
1.5 Hold-Up Battery (HUB)	Ensure good HUB	Install known good HUB

**STEP 2. POWER CHECKS:**

STEPS TO PERFORM	CHECKS TO MAKE	ACTIONS TO TAKE
2.1 Set FCTN to Z-FH or Z for RT-1523E/F	RT display lights?	YES: Go to Step 3.1 NO: Replace Battery Box **
	RT display then lights?	YES: Go to Step 3.1 NO: Replace RT
	RT display reads GOOD?	YES: Continue ↓ NO: Replace RT
	RT HUB lit?	NO: Go to STEP 3 YES: Replace HUB **
	RT HUB still lit?	NO: Go to STEP 3 YES: Replace RT

\*\* After completing a corrective action, continue with next Operational Check step.

\*\*\* See TM 11-5820-890-10-8 for operator procedures

**2.2. OPERATIONAL CHECK.** Continued

**STEP 3. RT SELF-TEST:**

STEPS TO PERFORM	CHECKS TO MAKE	ACTIONS TO TAKE
3.1 Set RT: COMSEC to CT FCTN to TST	N/A RT passes self-test?	N/A YES: Go to Step 3.2 NO: Disconnect antenna and HS from RT, rerun self-test
	RT then passes self-test?	YES: Reconnect HS and go to Step 3.2 NO: Replace RT
3.2 Set RT: FCTN to LD CHAN to MAN DATA to OFF	N/A N/A RT display reads 30000?	N/A N/A YES: Continue ↓ NO: Replace RT
	COMSEC alarm sounds? (RT-1523/A/B/D)	YES: Go to Step 3.3 NO: Replace RT
	Steady tone heard? (RT-1523C/E/F)	YES: Go to STEP 4 NO: Replace RT
3.3 Press PTT twice	Steady tone is heard	YES: Go to STEP 4 NO: Replace RT

**STEP 4. LOAD CHECKS:**

STEPS TO PERFORM	CHECKS TO MAKE	ACTIONS TO TAKE
4.1 Load RT with SC frequencies: Chan 1: 41000 Chan 2: 54000 Chan 3: 75000	SC frequencies load properly?	YES: Go to Step 4.2 NO: Replace RT
4.2 Load RT with COMSEC and FH data.* Note: Set RT controls to CT, LD, FH, MAN, and DATA OFF (Clear COMSEC alarm by pressing PTT twice, if required)	RT accepts fill?	YES: Go to Step 4.3 NO: Go to TS Chart 1
4.3 Set RT to STBY	RT shuts down properly?	YES: Go to Step 4.4 NO: Replace RT
4.4 Remove Main Battery Replace after 1 min. Set FCTN to SQ ON	N/A N/A RT retains COMSEC, FH, and SC data in both FH and SC modes?	N/A N/A YES: Go to Step 4.5 NO: Replace RT
4.5 Set RT FCTN to LD Load Battery Life Condition	N/A Battery Life Condition loads properly?	N/A YES: Go to STEP 5 NO: Replace RT

\* If using an Automated Net Control Device (ANCD) or Simple Key Loader (SKL), follow ICOM Fill procedure to load COMSEC keys and FH data in all 6 channels. Otherwise, load COMSEC keys and FH data in Channels 1, 2, and 3. If required, load COMSEC key in EGR using EGR load procedure. Refer to TM 11-5820-890-10-8 for load procedures.



**2.2. OPERATIONAL CHECK.** Continued

**STEP 5. TRANSMITTER CHECKS:\***

STEPS TO PERFORM	CHECKS TO MAKE	ACTIONS TO TAKE
5.1 Remove antenna from RT ANT, Connect RF cable from test set RADIO to RT ANT Connect test set ANT to dummy load Set test set MODE to FWD PWR Set RT: FCTN to SQ ON CHAN to 1 MODE to SC RF PWR to HI	N/A N/A (See para. 1.22, for setup) N/A N/A N/A N/A N/A N/A N/A	N/A N/A N/A N/A N/A N/A N/A N/A
5.2 Press PTT and test set Push-To-Test	Test set reads 2.0 W or greater?	YES: Go to Step 5.3 NO: Go to TS Chart 2
5.3 Press PTT	SIG display reads 4 or more?	YES: Go to Step 5.4 NO: Replace RT
5.4 Repeat above check for CHAN 2	SIG display reads 4 or more?	YES: Go to Step 5.5 NO: Replace RT
5.5 Repeat above check for CHAN 3	SIG display reads 4 or more?	YES: Go to Step 5.6 NO: Replace RT
5.6 Set RT CHAN to 1 Press PTT, count into HS	N/A Sidetone heard?	N/A YES: Go to Step 5.7 NO: Replace RT
5.7 Set test set MODE to FREQ Press PTT and test set Push-To-Test	N/A Test set reads 40998 to 41002?	N/A YES: Go to Step 5.8 NO: Replace RT
5.8 Set RT CHAN to 2 Press PTT and test set Push-To-Test	N/A Test set reads 53998 to 54002?	N/A YES: Go to Step 5.9 NO: Replace RT
5.9 Set RT CHAN to 3 Press PTT and test set Push-To-Test	N/A Test set reads 74998 to 75002?	N/A YES: Go to Step 5.10 NO: Replace RT
5.10 Set RT FCTN to RXMT Connect HS to RT RXMT Listen at HS	N/A N/A Rushing noise heard?	N/A N/A YES: Go to Step 5.11 NO: Replace RT
5.11 Press PTT	RT SIG display reads 4 or more	YES: Go to Step 5,12 NO: Replace RT
5.12 Set RT FCTN to SQ ON Connect HS to RT AUD/DAT Remove RF Cable from RTAN Connect ANT to RT ANT Press PTT	N/A N/A N/A N/A Sidetone heard in HS?	N/A N/A N/A YES: Go to Step 6 NO: Go to TS Chart 3 □

\*If unit SOP or tactical situation prohibits transmitting, use dummy load. Antenna cannot be checked

**2.2. OPERATIONAL CHECK.** Continued

**STEP 6. RECEIVER CHECKS:**

STEPS TO PERFORM	CHECKS TO MAKE	ACTIONS TO TAKE
6.1 Remove antenna from RT ANT Connect RF cable from test set RADIO to RT ANT Remove cable from test set ANT Set test set MODE to SENS SQ Set RT: CHAN to 3 COMSEC to PT FCTN to SQ ON	N/A N/A N/A N/A N/A N/A N/A	N/A N/A N/A N/A N/A N/A N/A
6.2 Press test set Push-To-Test	Test tone heard in handset?	YES: (For RT-1523/A/B) RT is good. YES: (For RT-5123C/D/E/F)Go to Step 7.1 NO: Replace RT

(End of Manpack Radio Operational Check; See TS Chart 4 for check if having trouble with transmitting / receiving data using data device.)

**Step 7. RCU/RT SELF-TEST:**

STEPS TO PERFORM	CHECKS TO MAKE	ACTIONS TO TAKE
7.1 Configure SIP/ASIP RT (RCU) and remoted RT for RCU operations	N/A	The RT-1523E/F requires two-wire adapter for portable RCU operation (two-wire adapter connects to AUX connector at rear of RT-1523E/F).
7.2 Set RCU FCTN to TST	RCU display reads GOOD for RCU self-test?	YES: Continue ↓ NO: Replace RCU
	RCU display then reads OPEN?	YES: Go to TS Chart 5 NO: Continue ↓
	RCU display reads GOOD for RT self-test?	YES: Go to Step 4 NO: Replace RT
7.3 Set RCU: FCTN to LD MODE to SC	N/A N/A	N/A N/A
7.4 RCU: Load SC frequencies: CHAN 1: 41000 CHAN 2: 54000 CHAN 3: 75000	N/A N/A N/A	N/A N/A N/A
7.5 Set RT: FCTN to LD MODE to SC *	SC frequencies load in RT?	YES: Go to Step 7.6 NO: Go to TS Chart 6
7.6 Set RT FCTN to REM	N/A	N/A
7.7 RCU: Press BATT/CALL pushbutton twice	RCU display reads [RT XX]?	YES: Go to STEP 7.8 NO: Replace RCU

**2.2. OPERATIONAL CHECK.** Continued

STEPS TO PERFORM	CHECKS TO MAKE	ACTIONS TO TAKE
7.8 Set RCU: FCTN to REM COMSEC to PT	N/A N/A	N/A N/A
7.9 RCU: Press BATT/CALL and PTT, and release	RCU display reads CALL?	YES: Go to Step 7.10 NO: Go to TS Chart 7
7.10 RCU: Press PTT and count into HS	Voice heard at RT?	YES: Go to Step 7.11 NO: Go to TS Chart 8
7.11 RT: Press BATT/CALL and PTT, and release	RT display reads CALL?	YES: Go to Step 7.12 NO: Go to TS Chart 9
7.12 RT: Press PTT and count into HS	Voice heard at RCU?	YES: End of RCU Check. NO: Go to TS Chart 10

\* RT-1523E/F will retain settings that were changed at the RCU when taken out of REM to LD. There is no need to change to SC mode.

**Step 8. HRCRD CHECK:**

8.1 Connect HRCRD to RT AUD/DATA and Battery Box connector.*	N/A	N/A
8.2 Press light button on HRCRD	HRCRD display lights?	YES: Continue ↓ NO: Replace Battery Box
	HRCRD display now lights?	YES: Continue ↓ NO: Replace HRCRD
	HRCRD display now lights?	YES: Continue ↓ NO: Replace Battery
8.3 Test all HRCRD features.	All features work.	YES: End of HRCRD Check. NO: Note discrepancies and continue to use until Transmit/Receive features is inoperable.

\* Only Battery Box CY-8523C may be with HRCRD. Refer to TM 11-5820-890-10-8 for features and use. RT-1523E/F connection to HRCRD is to AUD/DATA and AUX.

**Step 9. CDU/EGR CHECKS:**

9.1	Connect CDU to RT-1523E/F AUX connector J6*	N/A	N/A
9.2	Set RT FCTN switch to STBY, then REM	CDU display lights?	YES: Continue ↓ NO: Replace battery.
		CDU passes self-test?	YES: Continue ↓ NO: Replace CDU.
9.3	Press GPS key on RT	Display read NOGPS or OFF?	YES: If display reads NOGPS and EGR is installed replace RT. If display reads OFF, turn GPS on and continue ↓ . NO: Continue ↓
9.4	Load GPS time into RT	GPS time loads?	YES: Continue ↓ NO: Go to TS Chart 11.
9.5	Test all CDU features	All features work?	YES: End of CDU/EGR Checks. NO: Go to TS Chart 12.

\* CDU works in conjunction with handset H-250/U.



2.3. TROUBLESHOOTING FLOWCHARTS.

Chart 1

VARIABLE WILL NOT LOAD.  
(Sheet 1 of 1)

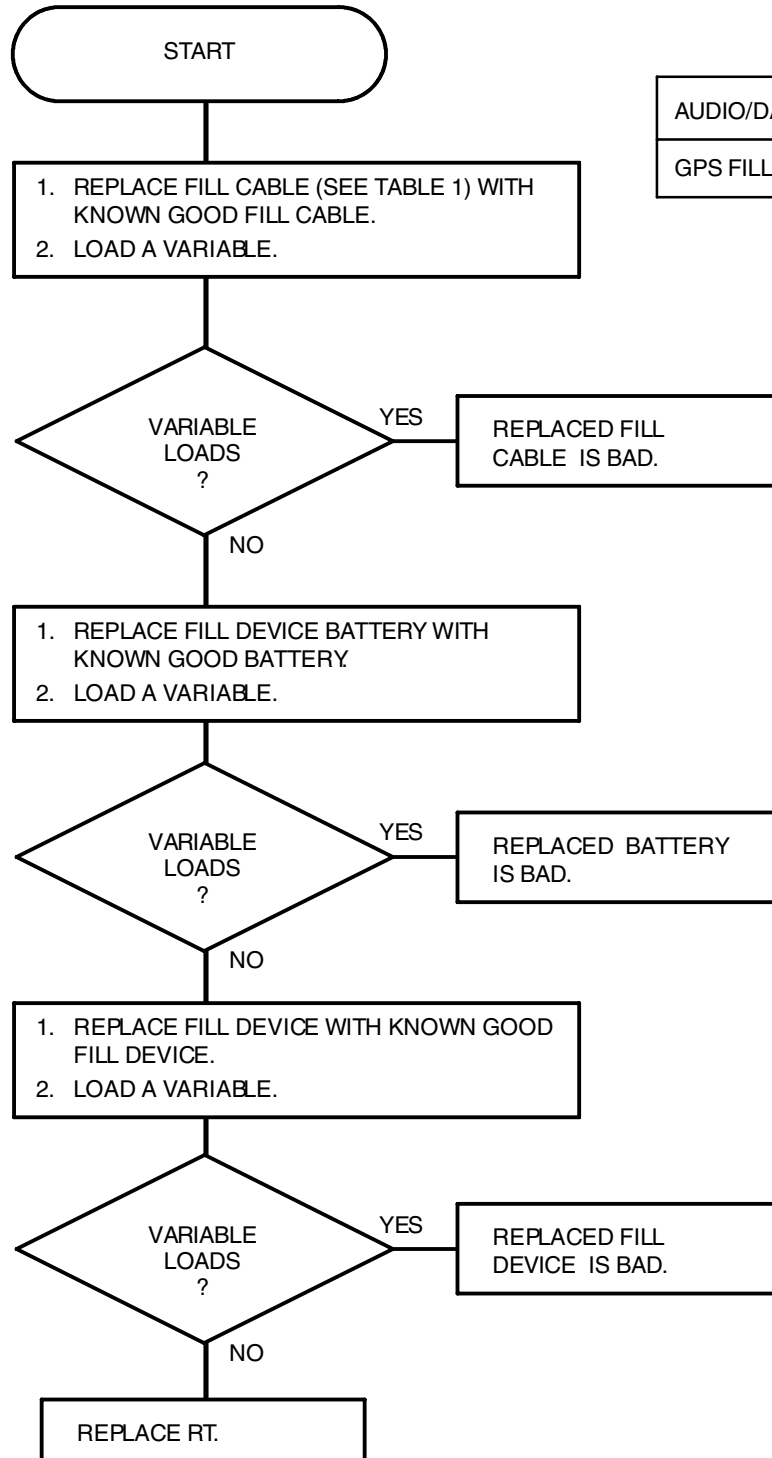

TABLE 1

AUDIO/DATA (FILL) CABLE	W4
GPS FILL CABLE	W20



2.3. TROUBLESHOOTING FLOWCHARTS. Continued

Chart 2

LOW OR NO POWER OUT.  
(Sheet 1 of 1)

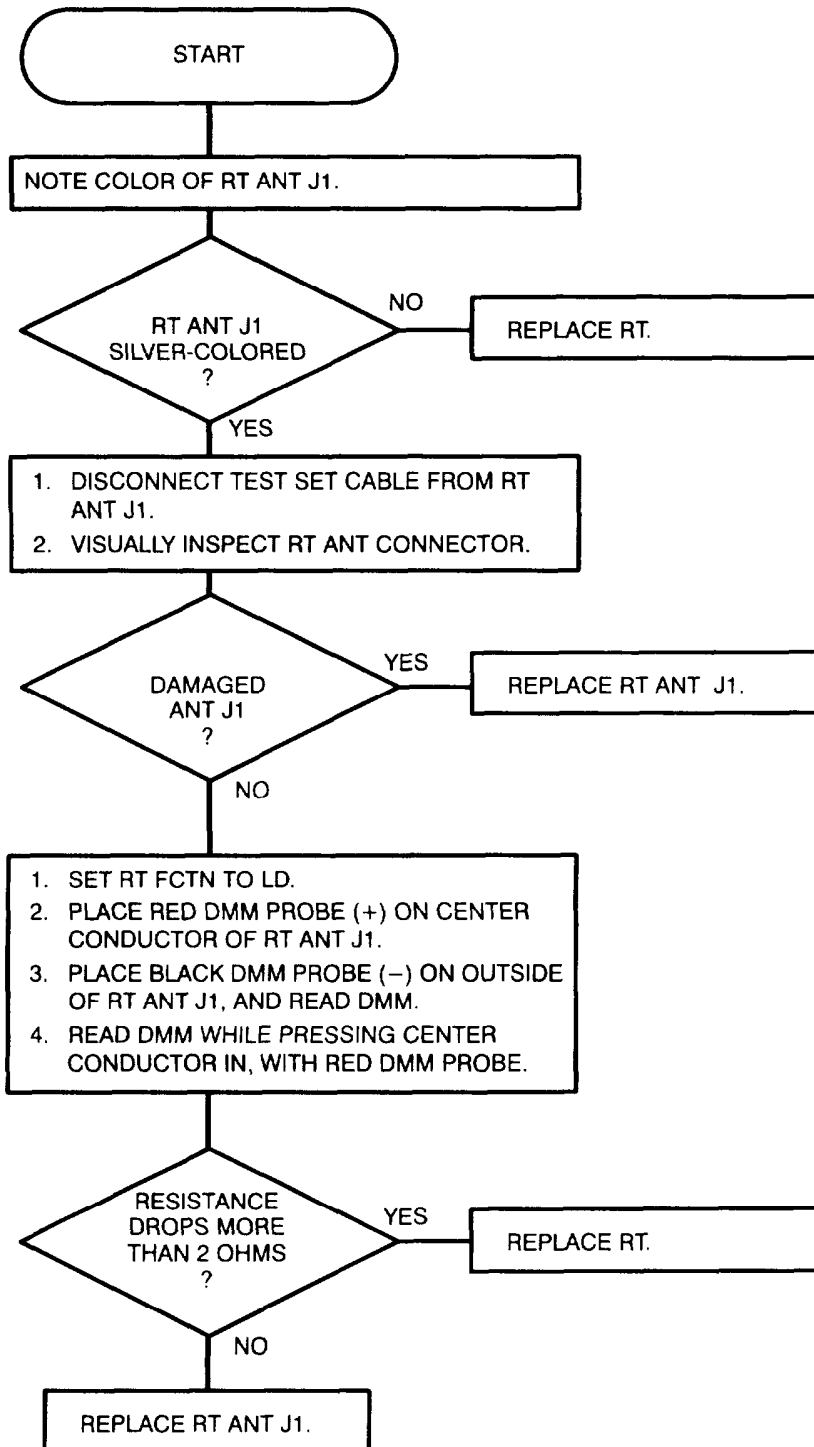

2.3. TROUBLESHOOTING FLOWCHARTS. Continued

Chart 3

LOSS OF SIDETONE.

(Sheet 1 of 2)

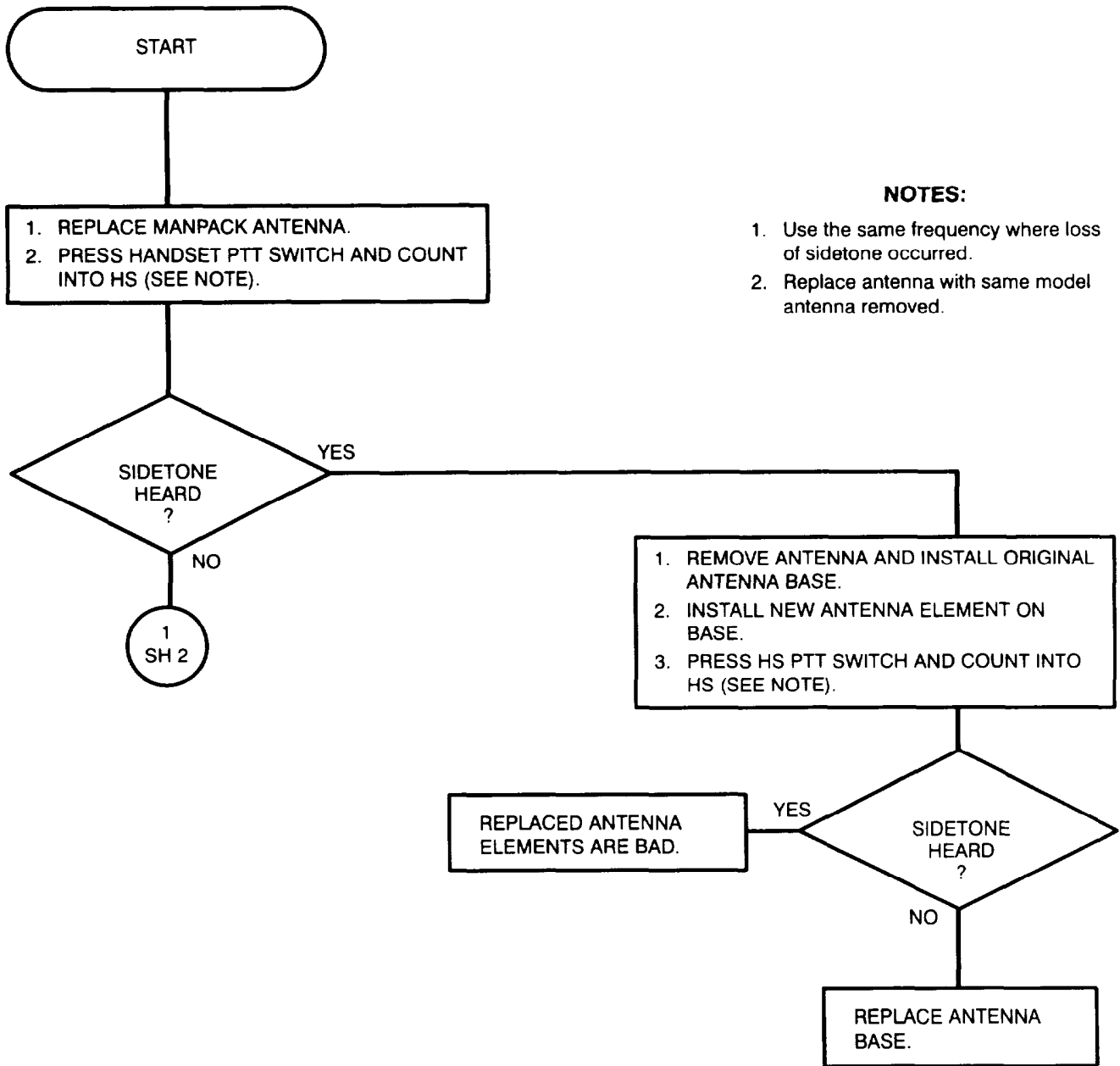

**NOTES:**

1. Use the same frequency where loss of sidetone occurred.
2. Replace antenna with same model antenna removed.



2.3. TROUBLESHOOTING FLOWCHARTS. Continued

Chart 3

LOSS OF SIDETONE.  
(Sheet 2 of 2)

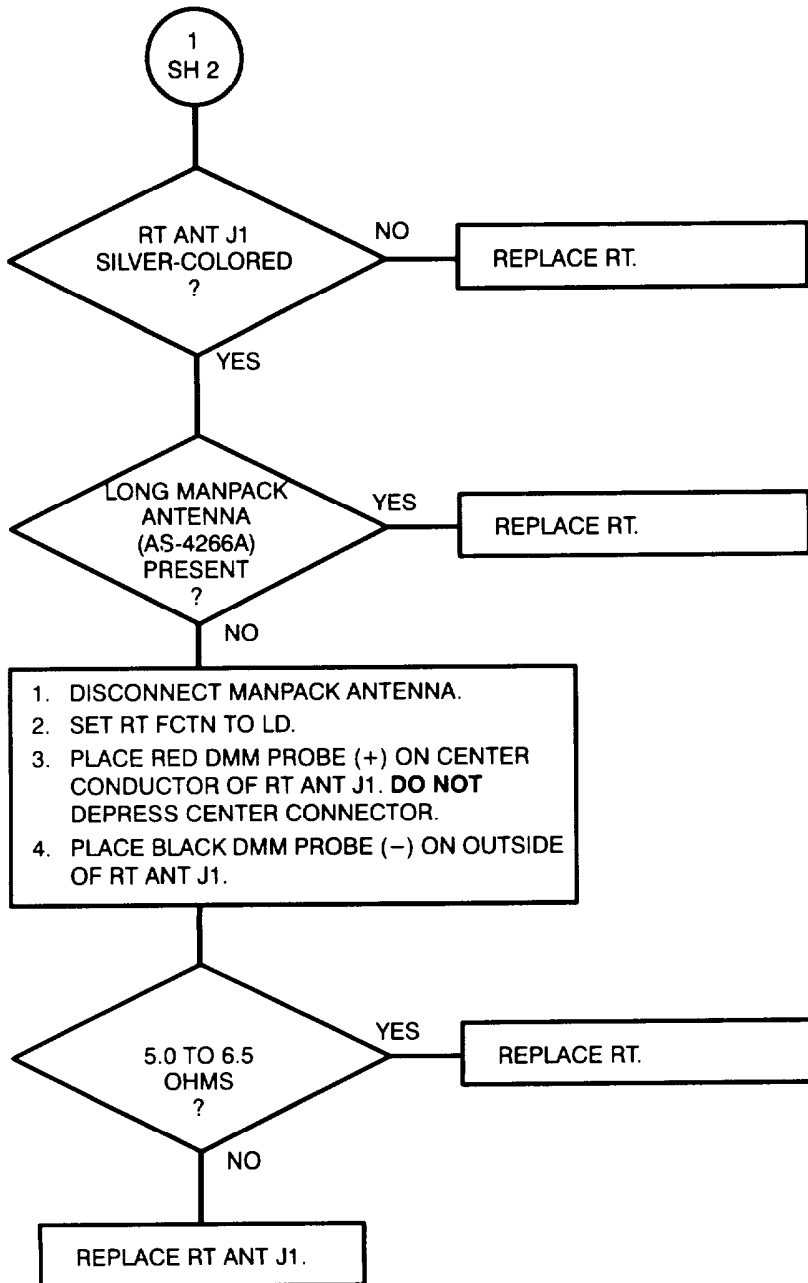

2.3. TROUBLESHOOTING FLOWCHARTS. Continued

Chart 4

RADIO WILL NOT OPERATE WITH DATA DEVICES.

(Sheet 1 of 2)

**NOTE:**

Data devices may be any type equipment which meet the RT data requirements.  
\*SINGARS provided cables schematics listed in Chap 4. For all other cables refer to Operator/Unit Level manual for Data Device.

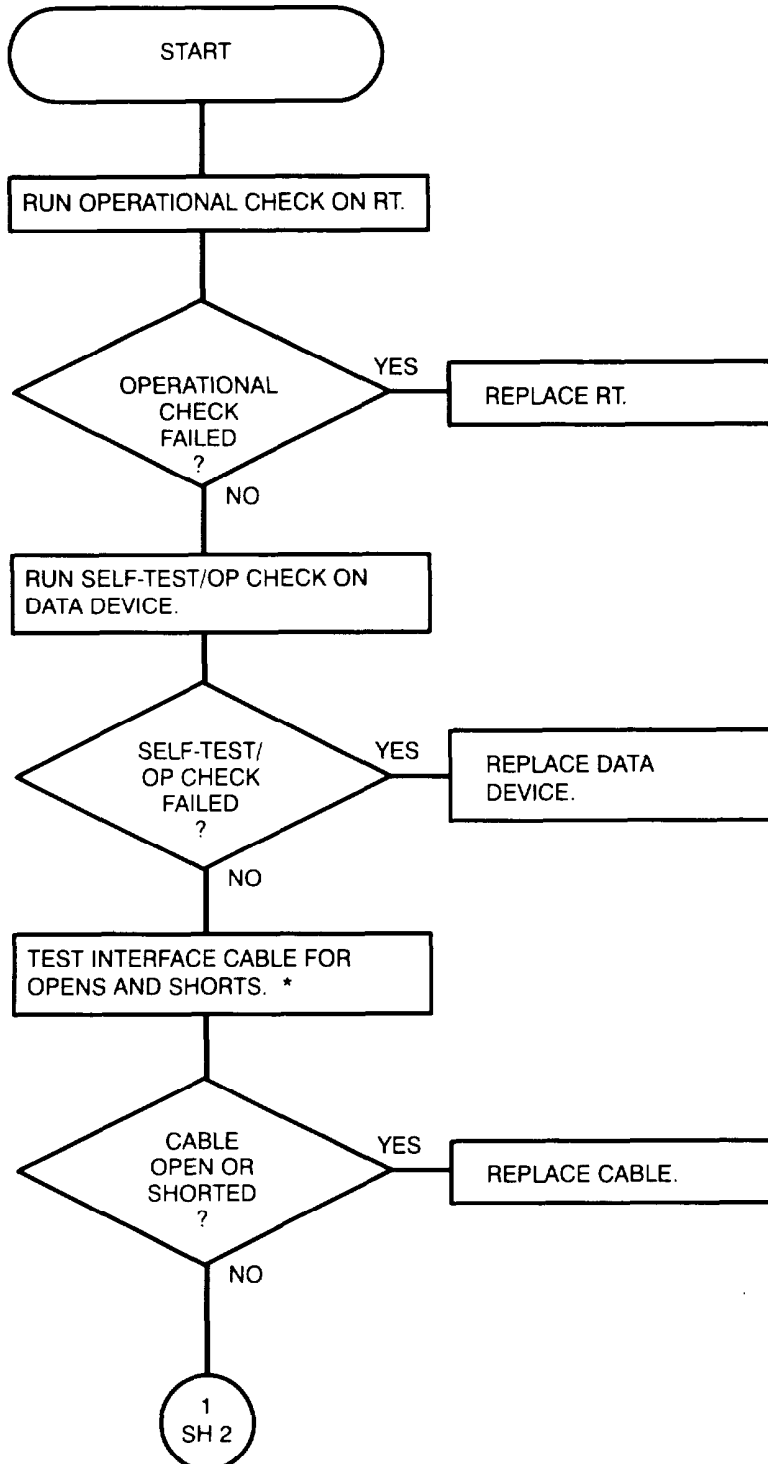

2.3. TROUBLESHOOTING FLOWCHARTS. Continued

Chart 4

RADIO WILL NOT OPERATE WITH DATA DEVICES.

(Sheet 2 of 2)

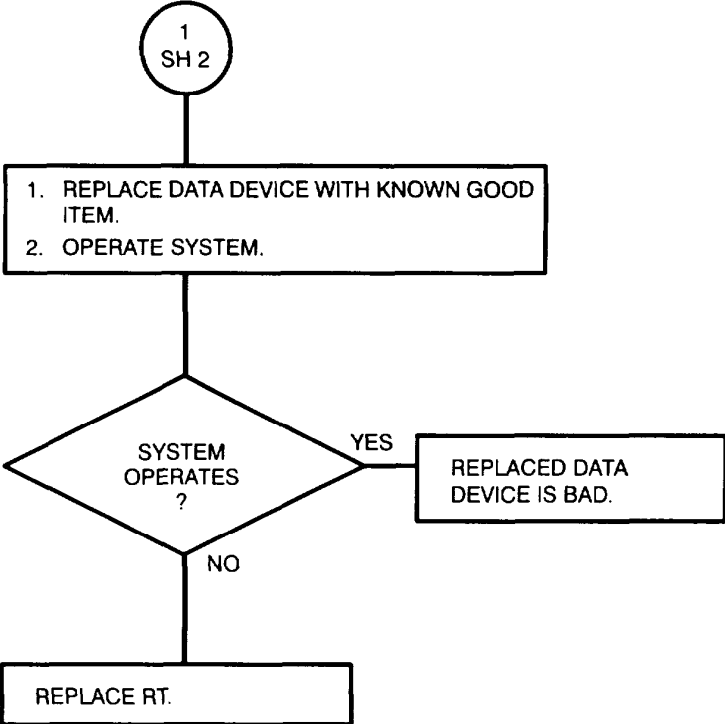

**NOTE:**

If a data device is not available, replace the RT  
If the system operates, the RT is bad.

2.3. TROUBLESHOOTING FLOWCHARTS. Continued

CHART 5

RCU DISPLAY READS "OPEN" DURING SELF-TEST.

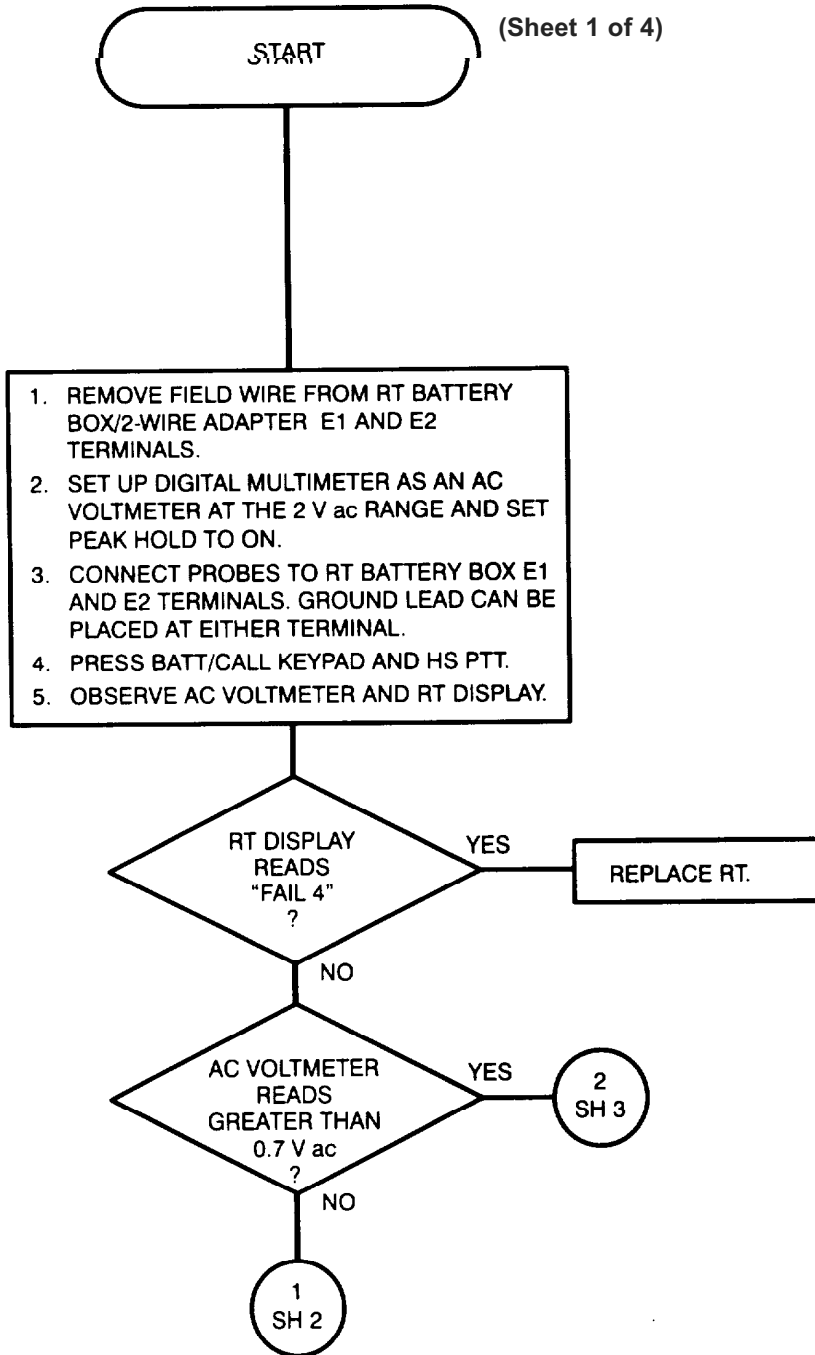

2.3. TROUBLESHOOTING FLOWCHARTS. Continued

CHART 5  
RCU DISPLAY READS "OPEN" DURING SELF-TEST.  
(Sheet 2 of 4)

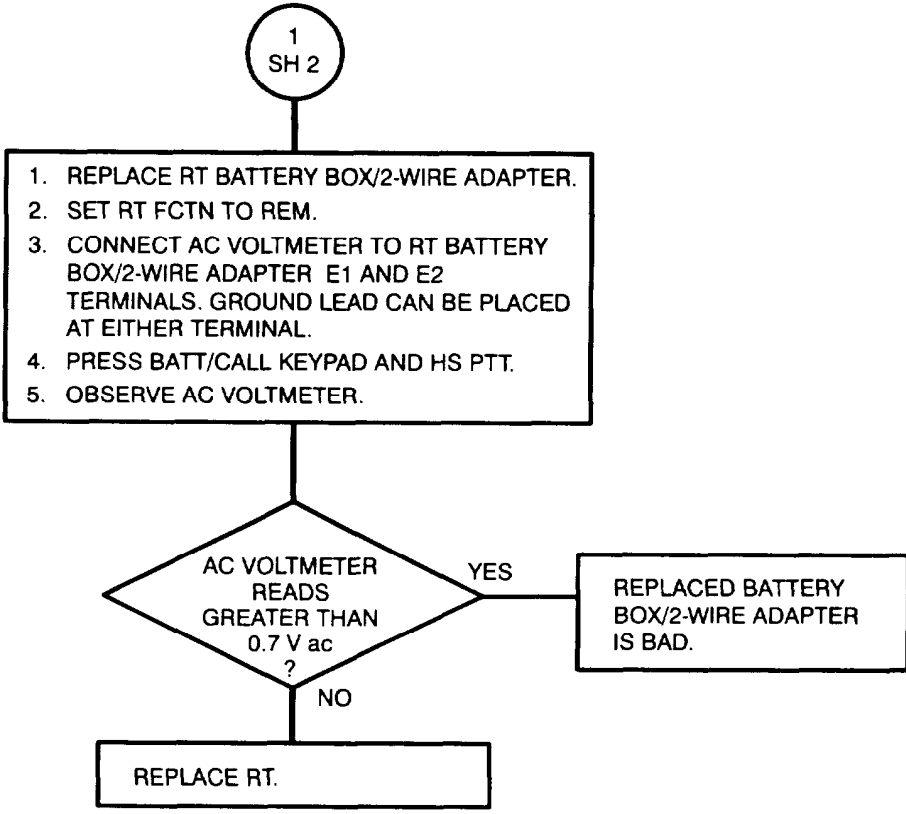

2.3. TROUBLESHOOTING FLOWCHARTS. Continued

CHART 5  
RCU DISPLAY READS 'OPEN' DURING SELF-TEST.  
(Sheet 3 of 4)

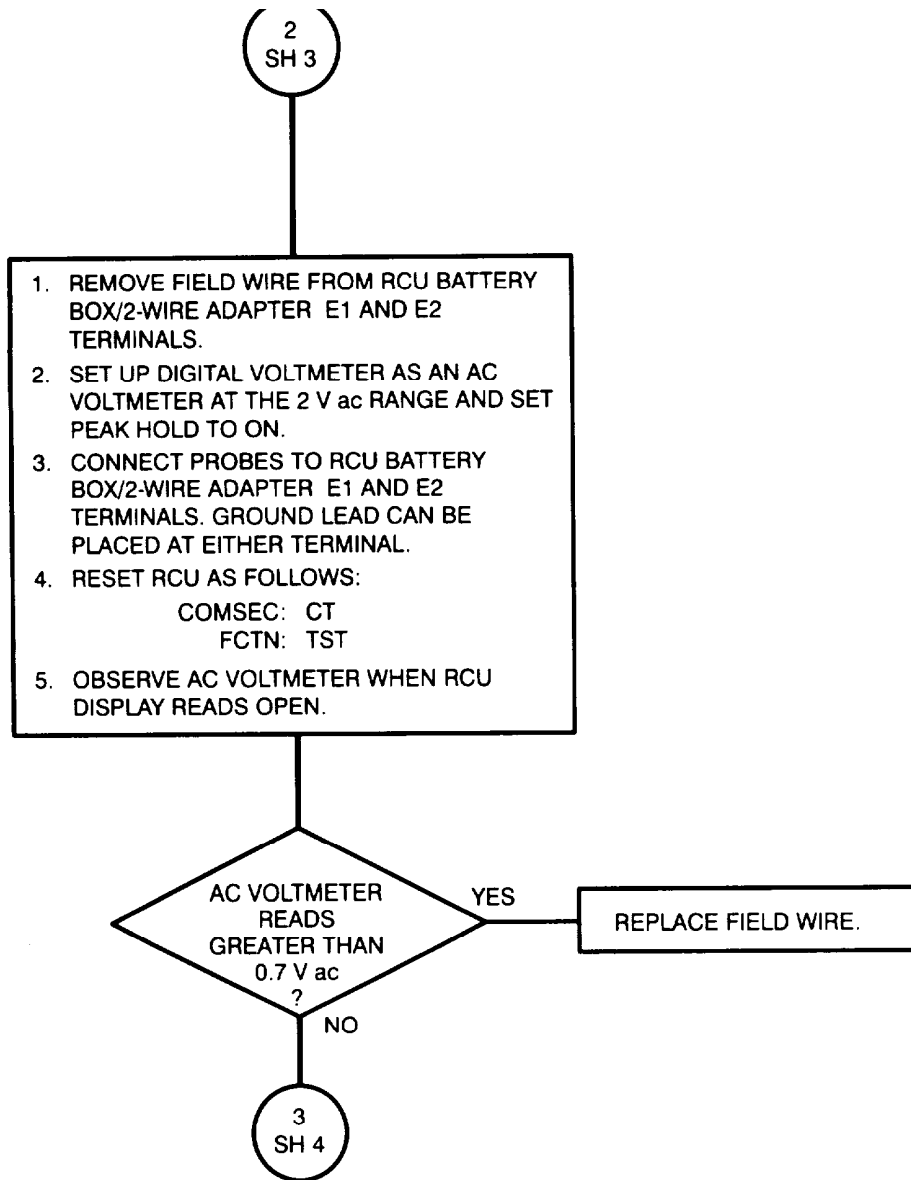

2.3. TROUBLESHOOTING FLOWCHARTS. Continued

CHART 5  
 RCU DISPLAY READS 'OPEN' DURING SELF-TEST.  
 (Sheet 4 of 4)

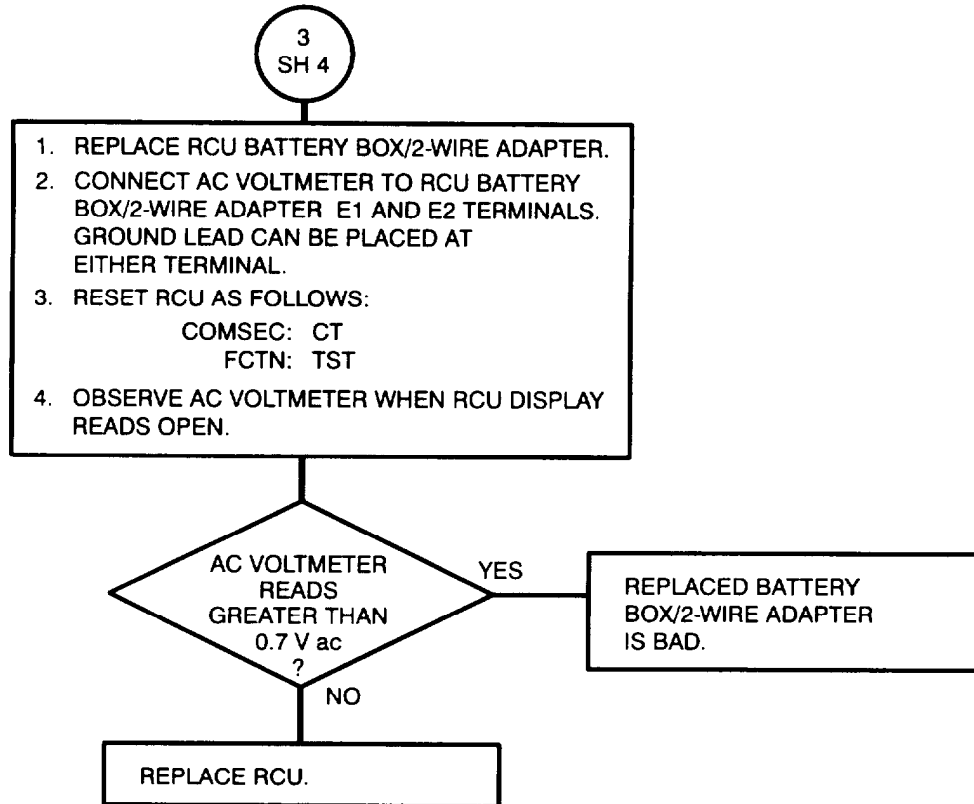

2.3. TROUBLESHOOTING FLOWCHARTS. Continued

CHART 6

RT WILL NOT LOAD FREQUENCIES FROM RCU.

(Sheet 1 of 1)

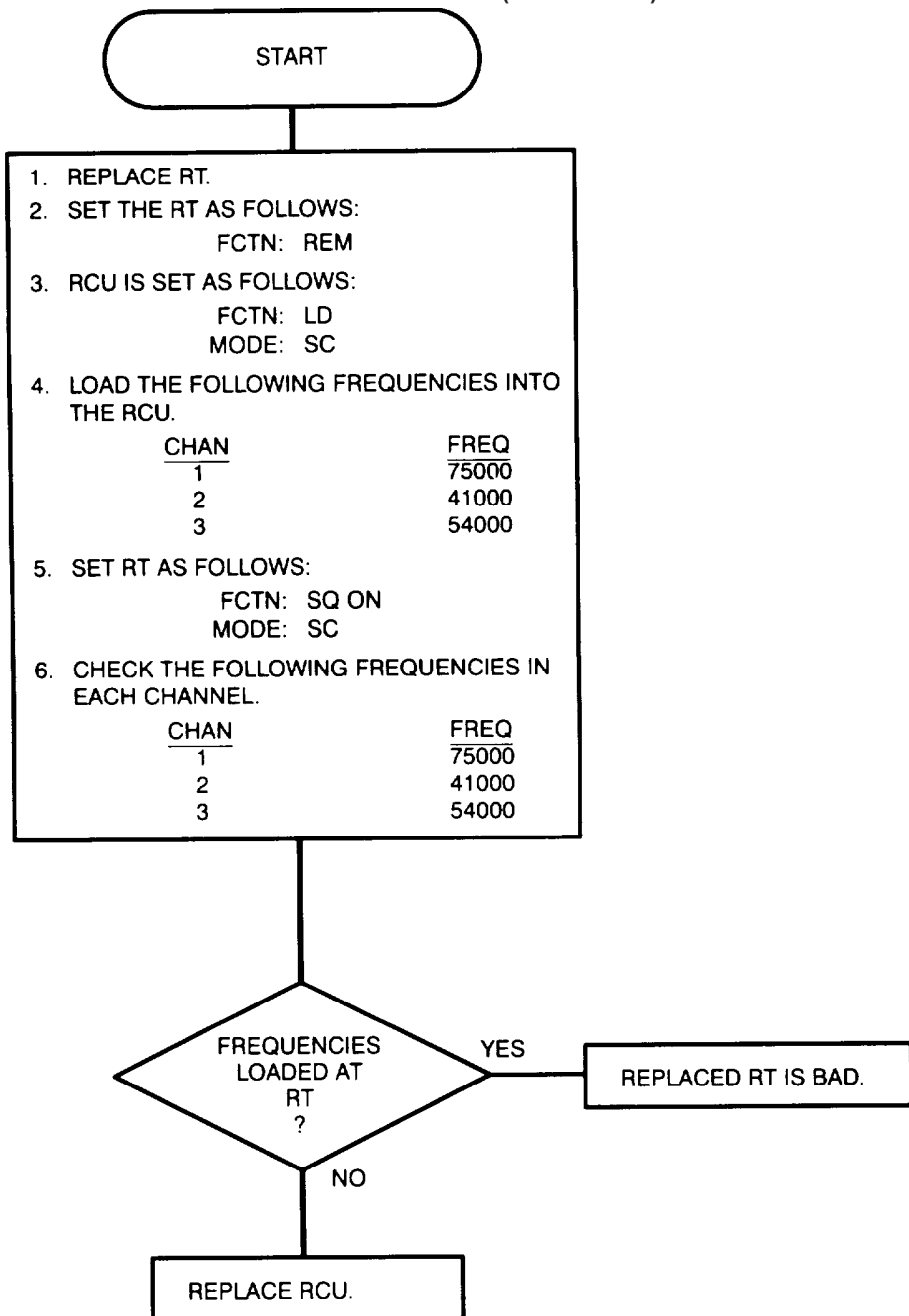



2.3. TROUBLESHOOTING FLOWCHARTS. Continued

CHART 7  
 NO CALL FUNCTION AT THE RCU.  
 (Sheet 1 of 1)

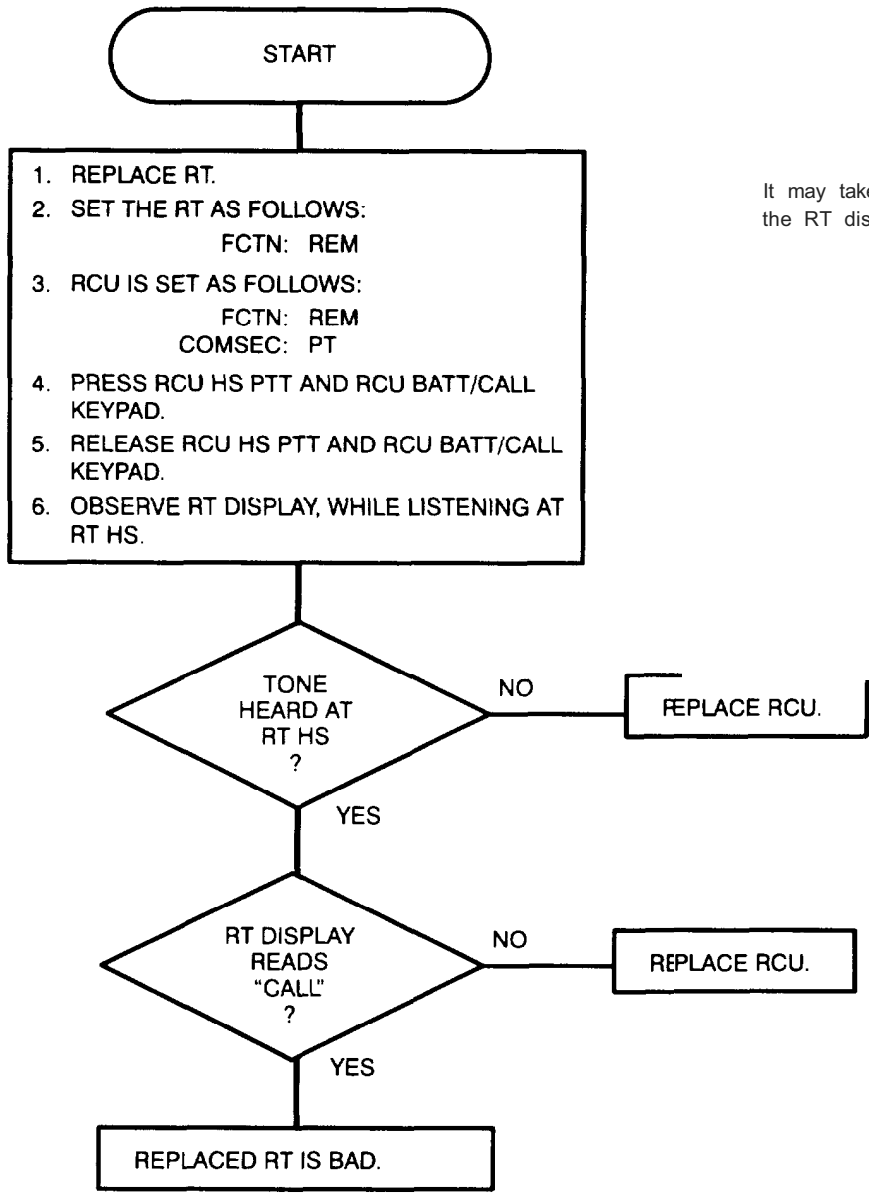

**NOTE:**

It may take up to 12 seconds before the RT display will display "CALL".

2.3. TROUBLESHOOTING FLOWCHARTS. Continued

CHART 8  
NO INTERCOM TALK FUNCTION FROM RCU TO RT.  
(Sheet 1 of 1)

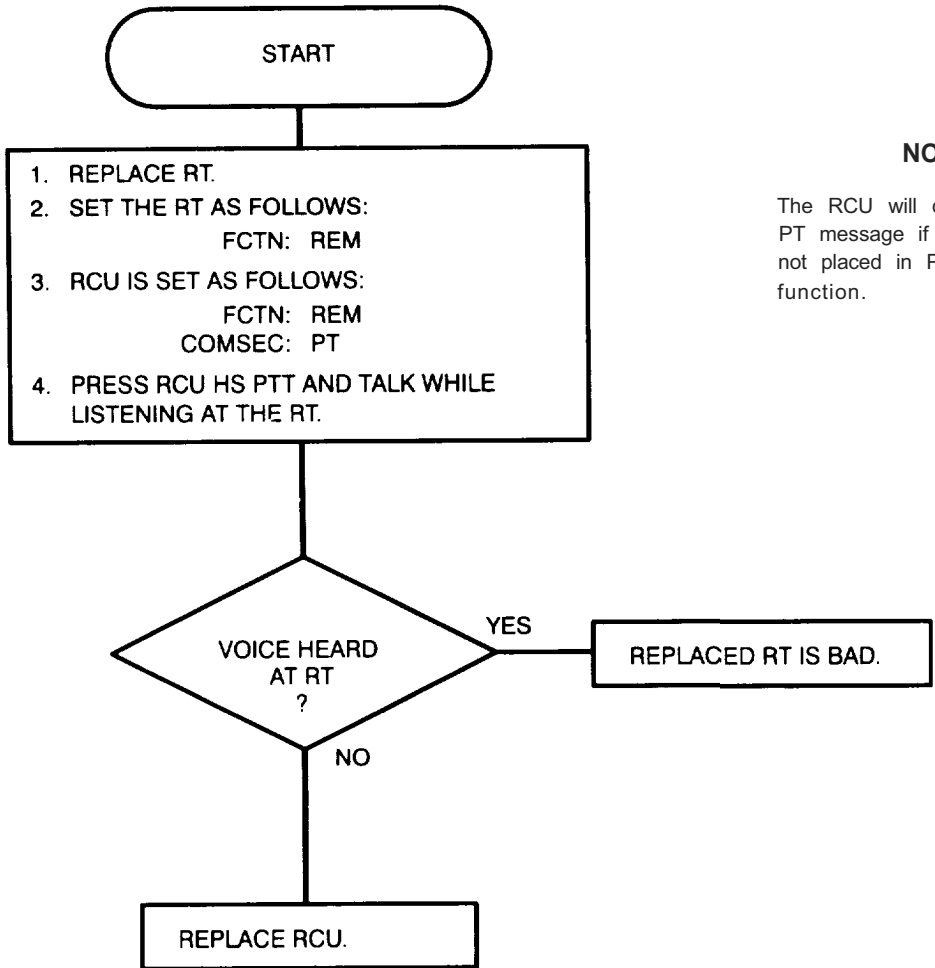

**NOTE:**

The RCU will display an ERROR/GO PT message if the COMSEC switch is not placed in PT for the intercom function.

2.3. TROUBLESHOOTING FLOWCHARTS. Continued

CHART 9  
NO CALL FUNCTION AT THE RT.  
(Sheet 1 of 1)

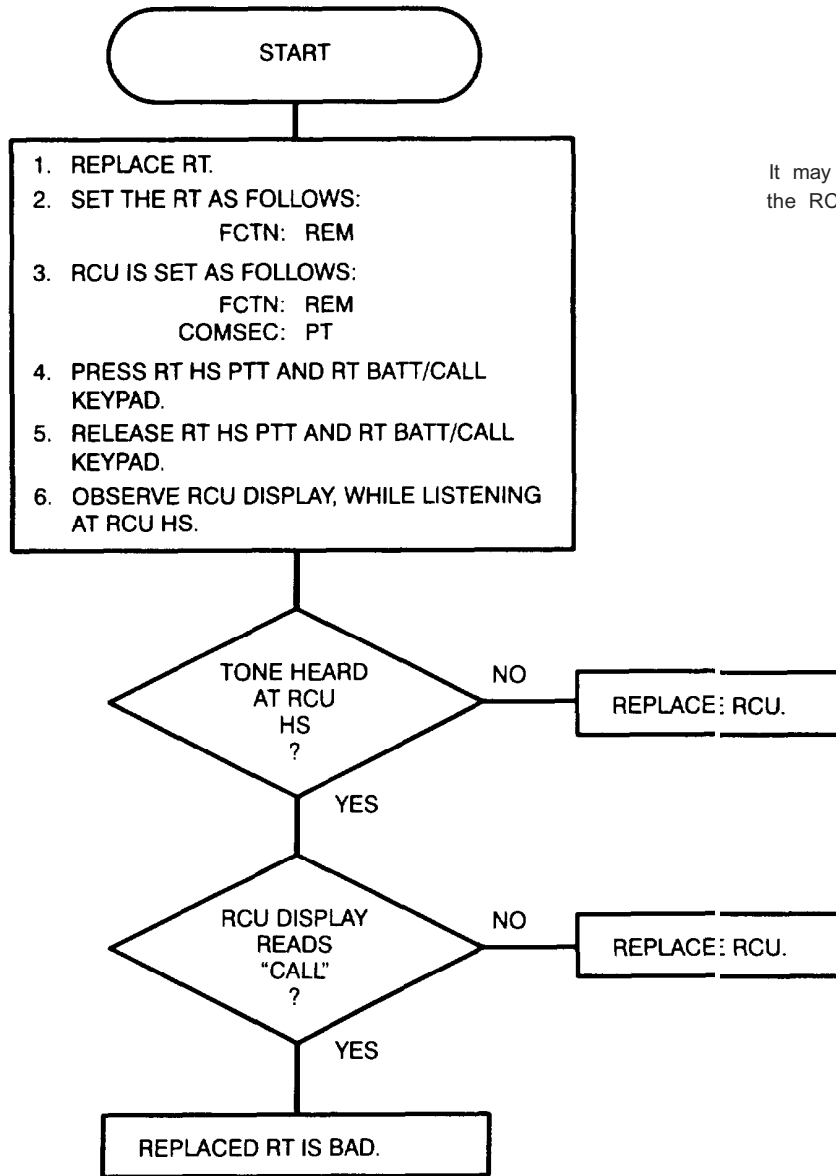

**NOTE:**

It may take up to 12 seconds before the RCU display will display CALL.

2.3. TROUBLESHOOTING FLOWCHARTS. Continued

CHART 10  
NO INTERCOM TALK FUNCTION FROM RT TO RCU.  
(Sheet 1 of 1)

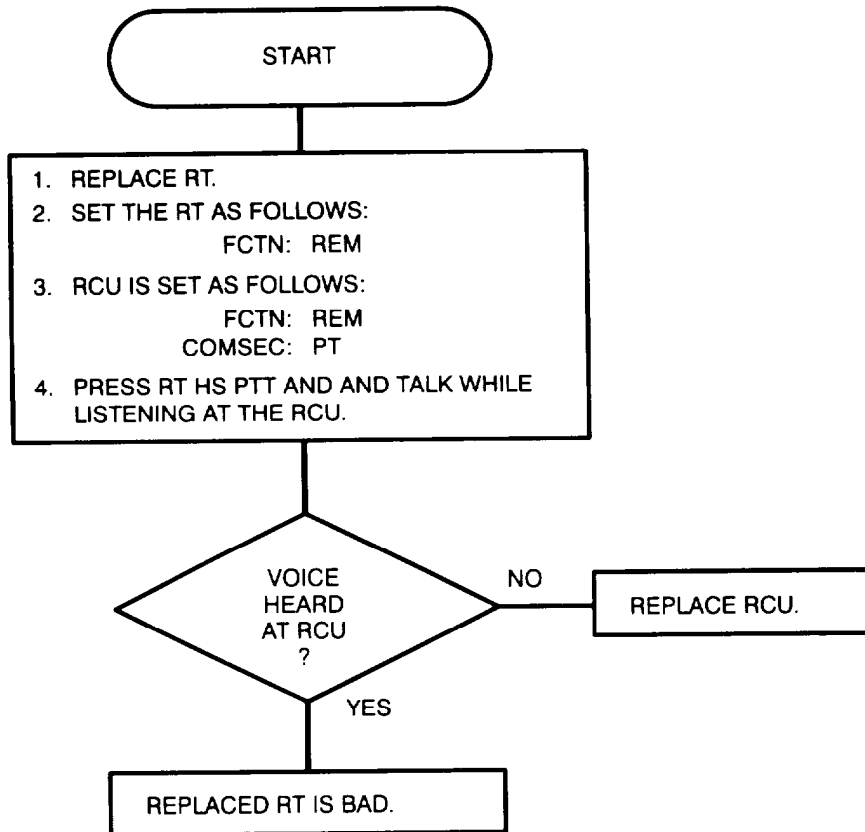

2.3. TROUBLESHOOTING FLOWCHARTS. Continued

**CHART 11**  
**RT WITH EGR WILL NOT LOAD GPS TIME.**  
 (Sheet 1 of 1)

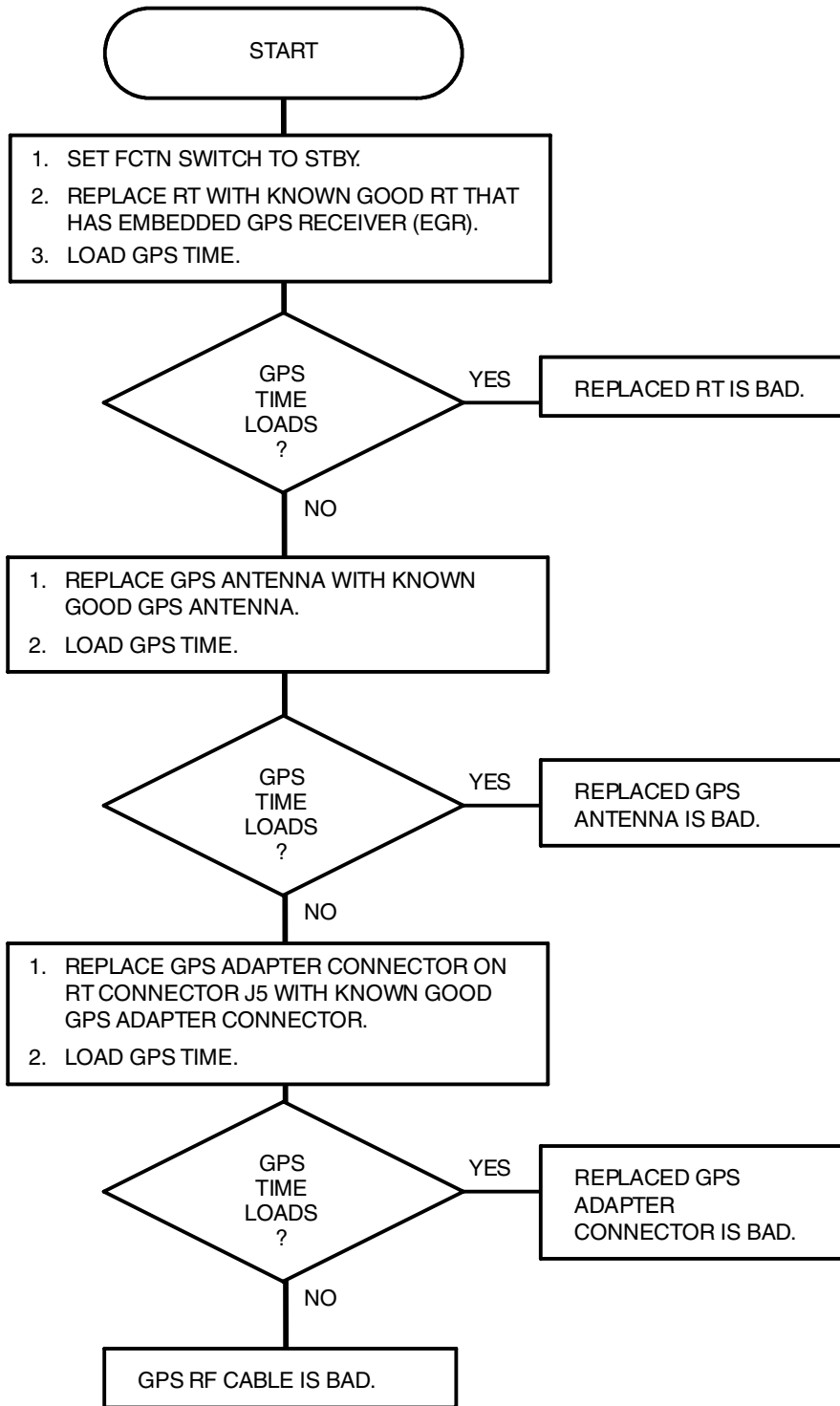

2.3. TROUBLESHOOTING FLOWCHARTS. Continued

CHART 12  
CDU FEATURES DO NOT WORK.  
(Sheet 1 of 1)

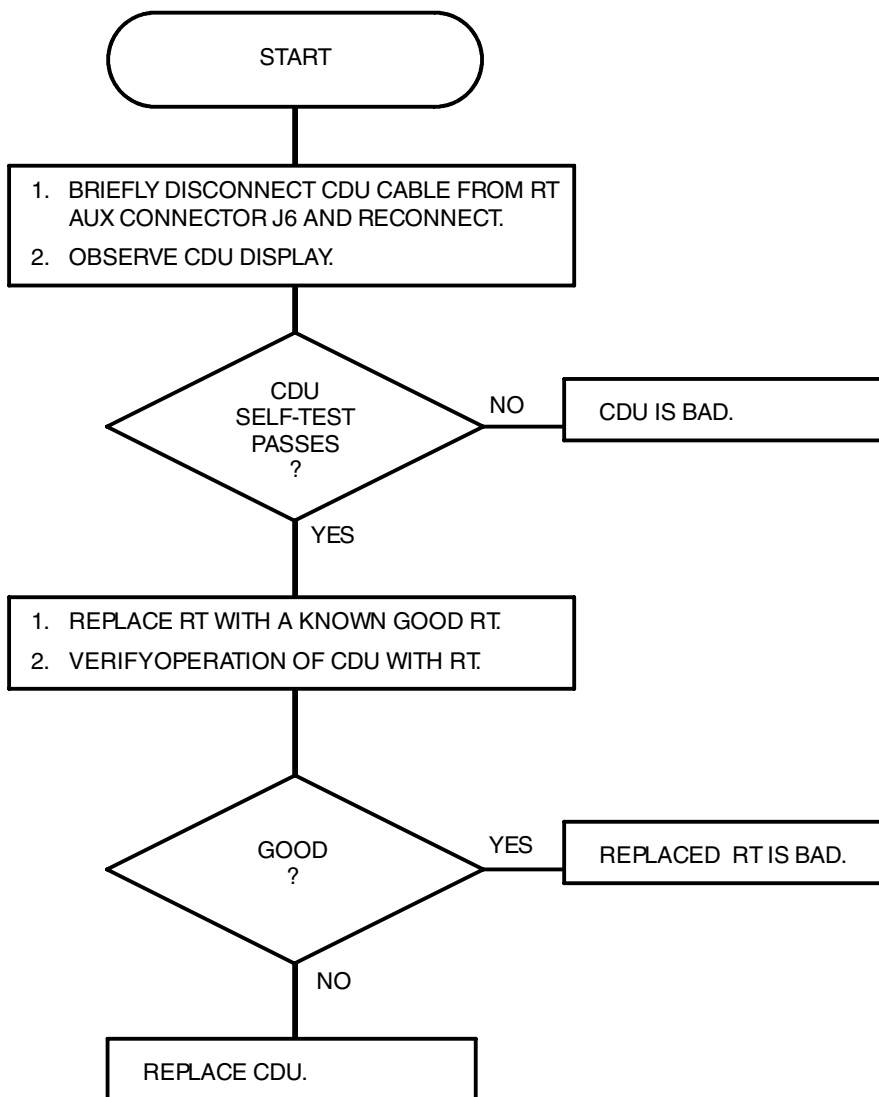

## CHAPTER 3

### VEHICULAR RADIO CONFIGURATIONS

Subject	Para	Page
Operational Check .....	3.1	3-1
Troubleshooting Flowcharts .....	3.2	3-9

#### 3.1. OPERATIONAL CHECK.

The following Operational Check for Vehicular Radio Configurations, identical in both TM 20-1 and TM 20-3 (Unit Maintenance Handbook) is used initially to identify what is wrong with a vehicular radio system and determine what corrective action needs to be taken at Unit Maintenance. After corrective action has been taken, this Operational Check is used a second time to verify that the system is fully operational.

The Unit Maintainer, using this Operational Check, determines if RT-A, RT-B, or both are to be checked, and whether the problem radio is short range or long range. The Unit Maintainer also determines which other items of ancillary equipment such as intercommunications systems, loudspeakers, and control-monitors, are involved and skips those Operational Check actions that do not apply. Wiring diagrams of Short Range RT-A and RT-B, plus Long Range RT-A and RT-B, are provided at the front of the Troubleshooting section (Paragraph 3.2) for ease of reference.

In checking vehicular radio systems that contain a Vehicular Amplifier-Adapter (VAA), the Unit Maintainer must determine which of the five current models is present: AM-7239 SERIES. The principal difference among these models is in the method of selecting LOCAL and REMOTE operation. The AM-7239 uses a shorting bar which is changed by removing a cover panel on the side of the VAA. The AM-7239A uses a shorting jumper, also located behind a cover panel. The AM-7239B, AM-7239C and AM-7239D uses a LOCAL/REMOTE switch which is visible to the left of the RT-B J7 system connector. AM-7239E uses a LOCAL/REMOTE switch which is visible to the right of CB1. Chapter 1 provides both explanations and graphics of these differences (refer to paragraph 1.9.e). Whenever necessary, Operational Checks and Troubleshooting Flowcharts/Guides provide separate actions by VAA model.

Corrective actions are either specifically stated (for example, Replace RT), or the Unit Maintainer is advised of the Troubleshooting Flowchart (TS CHART) to use. Use of the Operational Check after corrective action has been taken helps to ensure that the vehicular radio is in fact operational, and greatly reduces the possibility of false pulls at Unit Maintenance.

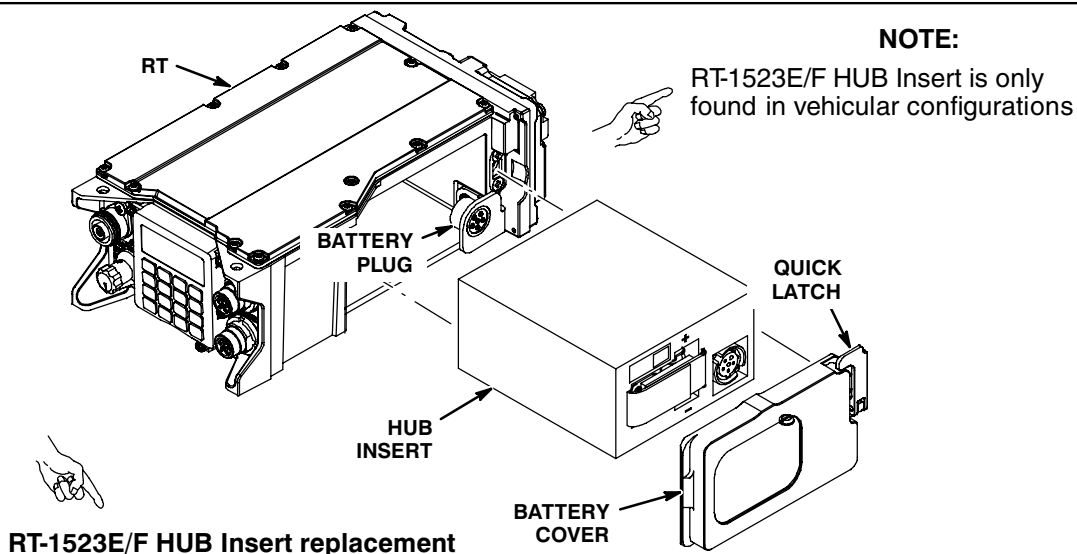

**3.1. OPERATIONAL CHECK.** Continued

**IMPORTANT POINTS TO REMEMBER IN USING THE OPERATIONAL CHECK**

- When an Operational Check step involves an item of equipment which is not used in the system being checked, skip the appropriate portion of that step and continue to the next step.
- It is important that Operational Check steps be performed as stated and in the order presented in the manual.
- If the vehicular radio system being checked includes an AN/VIC-1 (VIC) intercom, determine as early as possible whether the problem is in the VIC or the radio; then troubleshoot that part of the system. If you need to troubleshoot the VIC, see Chapter 2 TM 20-2.
- Once you have completed the Operational Check, and the problem appears to be solved, make a communications check (unless prohibited by unit SOP or the tactical situation) and repeat the Operational Check to ensure the system is completely operational.
- When removing or installing components ensure VAA CB1 is in OFF position.
- Do not accept power outputs less than those specified.
- Before beginning an Operational Check on any vehicular radio system, verify that you have good power with engine running and engine off. Obtain assistance of unit vehicle mechanic as required.

**OPERATIONAL CHECK FOR VEHICULAR RADIOS**  
**(Short Range RT-A, RT-B, and Long Range RT-A, RT-B)**

**STEP 1. PREPARATION:**

STEPS TO PERFORM	CHECKS TO MAKE	ACTIONS TO TAKE
1.1 Set RT: FCTN to OFF CHAN to MAN MODE to SC RF PWR to HI VOL to Mid-Range DIM to Full CW COMSEC to Z	N/A N/A N/A N/A N/A N/A N/A	N/A N/A N/A N/A N/A N/A N/A
1.2 Set Vehicular Amplifier-Adapter (VAA): CB1 to OFF DS1 to Full CCW AM-7239 Series: If LS-671 or VIC is used: If neither is used:	N/A N/A Ensure VAA is set to REMOTE. Ensure VAA is set to LOCAL.	N/A N/A N/A N/A
1.3 Set all LS-671 Loudspeakers: CB1 to OFF DS1 to Full CCW VOL to OUT/Mid-Range	N/A N/A N/A	N/A N/A N/A
1.4 Set PA Mount, MT-6353: CB1 to OFF DS1 to Full CCW	N/A N/A	N/A N/A
1.5 Handset (HS), H-250: Connect RT-A HS to VAA J3 Connect RT-B HS to VAA J2**	Ensure that HS used is operational * N/A N/A	Install known good HS N/A N/A

\* And disconnect all other HS.

\*\* If AM-7239/C/D/E are used, disconnect W-4 from VAA and RT. Connect H-250 to RT AUD/DATA. W-4 only needs to be connected when transmitting Packet Data.



**3.1. OPERATIONAL CHECK.** Continued

STEPS TO PERFORM	CHECKS TO MAKE	ACTIONS TO TAKE
1.6 Control Display Unit***:	Ensure CDU is operational.	Install known good CDU
Connect CDU Vehicular Adapter Cable to AM-7239E connector J9	N/A	N/A
Connect CDU to CDU Vehicular Adapter Cable connector RT A	N/A	N/A

\*\*\* See TM 11-5820-890-10-8 for operator procedures.

**STEP 2. POWER CHECKS:**

STEPS TO PERFORM	CHECKS TO MAKE	ACTIONS TO TAKE
2.1 Set VAA CB1 to ON and RT-A LS-671 CB1 ON	VAA CB1 trips? *	NO: Continue ↓ YES: Go to TS Chart 1
	VAA DS1 lights?	YES: Continue ↓ NO: Go to TS Chart 2
	VAA DS1 blinks continuously?	NO: Continue ↓ YES: Replace VAA
	LS-671 CB1 trips?	NO: Continue ↓ YES: Replace LS-671
	LS-671 DS1 lights?	YES: Go to Step 2.2 NO: Go to TS Chart 3
2.2 Set RT-B LS-671 CB1 ON and RT-A LS-671 CB1 OFF	LS-671 CB1 trips?	NO: Continue ↓ YES: Replace LS-671
	LS-671 DS1 light?	YES: Go to Step 2.3 NO: Go to TS Chart 4
2.3 Set RT-A LS-671 CB1 to ON and set PA mount CB1 to ON	PA Mount CB1 trips?	NO: Continue ↓ YES: Go to TS Chart 5
	PA Mount DS1 lights?	YES: Go to Step 2.4 NO: Go to TS Chart 6
2.4 Set RT FCTN to Z-FH or Z for RT-1523E /F	RT display lights?	YES: Continue ↓ NO: Go to TS Chart 7
	RT display reads GOOD?	YES: Continue ↓ NO: Replace RT if it reads other than GOOD
	RT HUB lit? **	NO: Go to STEP 3 YES: Replace HUB
	RT HUB still lit?	NO: Go to STEP 3 YES: Replace RT

\* If VAA CB1 still trips after completing a TS Chart 1 corrective action, go back to TS Chart 1 and continue.

\*\* RT-1523E/F does not have a HUB display.

**3.1. OPERATIONAL CHECK.** Continued

**STEP 3. RT SELF-TEST:**

STEPS TO PERFORM	CHECKS TO MAKE	ACTIONS TO TAKE
3.1 Set RT: COMSEC to CT FCTN to TST	N/A RT display reads FAIL 6?	N/A NO: Continue ↓ YES: Go to TS Chart 8
	RT passes self-test?	YES: Go to Step 3.2 NO: Disconnect all cables from front of RT; rerun self-test
	RT now passes self-test?	YES: Reconnect all cables to front of RT and go to Step 3.2 NO: Replace RT
3.2 Set RT: FCTN to LD CHAN to MAN DATA to OFF	N/A N/A RT display reads 30000?	N/A N/A YES: Continue ↓ NO: Replace RT
	COMSEC alarm heard at HS/loudspeaker?*( For RT-1523/A/B/D)	YES: Go to Step 3.3 NO: If no external devices, go to TS Chart 9 NO: If using external devices, go to TS Chart 10
	Steady tone heard at HS/loudspeaker?*( For RT-1523C/E/F)	YES: Go to STEP 4 NO: If no external devices, go to TS Chart 9 NO: If using external devices, go to TS Chart 10
3.3 Press PTT twice	Steady tone is heard	YES: Go to STEP 4 NO: If no external devices, go to TS Chart 9 NO: If using external devices, go to TS Chart 10

\* External devices (LS 671 Speaker)

**STEP 4. LOAD CHECKS:**

STEPS TO PERFORM	CHECKS TO MAKE	ACTIONS TO TAKE
4.1 Load RT with SC frequencies: Chan 1: 41000 Chan 2: 54000 Chan 3: 75000	SC frequencies load properly?	YES: Go to Step 4.2 NO: Replace RT
4.2 Set RT MODE to FH and load RT with COMSEC and FH data*	RT accepts fill?	YES: Go to Step 4.3 NO: Go to TS Chart 11
4.3 Load test sync time (82/09:36)	Test sync time loads properly?	YES: Go to Step 4.4 NO: Replace RT.
4.4 Set RT to STBY	RT shuts down properly?	YES: Go to Step 4.5 NO: Replace RT

**3.1. OPERATIONAL CHECK.** Continued

STEPS TO PERFORM	CHECKS TO MAKE	ACTIONS TO TAKE
4.5 Set CB1 to OFF Wait 1 min. Set CB1 to ON Set RT FCTN to SQ ON	N/A N/A RT retains COMSEC, FH, and SC data in both FH and SC modes?	N/A N/A YES: Go to STEP 5 NO: Replace RT

NOTE If using an Automated Net Control Device (ANCD) follow ICOM Fill procedures to load COMSEC key and FH data in all 6 channels. Otherwise, load COMSEC keys and FH data in Channels 1, 2, and 3

**STEP 5. TRANSMITTER CHECKS:\***

STEPS TO PERFORM	CHECKS TO MAKE	ACTIONS TO TAKE
5.1 Remove RF cable from RT ANT, Connect test set cable from test set RADIO to RT ANT. Connect vehicular antenna cable to test set ANT and dummy load. Set test set MODE to FWD PWR Set RT: CHAN to 1 MODE to SC COMSEC to CT	N/A N/A (See para. 1.22 for setup) N/A N/A N/A N/A N/A N/A	N/A N/A N/A N/A N/A N/A N/A
5.2 Press PTT and test set Push-To-Test	Test set reads 2W or greater?	YES: Go to Step 5.3 NO: Go to TS Chart 12
5.3 Set test set MODE to RVS PWR Press PTT and test set Push-To-Test	N/A Test set reads no more than 1/3** of FWD PWR?	N/A YES: Go to Step 5.4 NO: Go to TS Chart 12
5.4 Press PTT	RT SIG display reads 4 or more?	YES: Go to Step 5.5 NO: Replace RT
5.5 Set RT CHAN to 2 Repeat FWD and RVSPWR check for CHAN 2	N/A Test set reads no more than 1/3** of FWD PWR?	N/A YES: Go to Step 5.6 NO: Go to TS Chart 12
5.6 Set RT CHAN to 3 Repeat FWD and RVSPWR check for CHAN 3	N/A Test set reads no more than 1/3** of FWD PWR?	N/A YES: Go to Step 5.7 NO: Go to TS Chart 12
5.7 Set RT to CHAN 1 Press PTT, count into HS	N/A Sidetone heard?	N/A YES: Go to Step 5.8 NO: Got to TS Chart 13
5.8 Set test set MODE to FREQ Press PTT and test set Push-To-Test	N/A Test set reads 40998 to 41002?	N/A YES: Go to Step 5.9 NO: Replace RT
5.9 Set RT CHAN to 2 Press PTT and test set Push-To-Test	N/A Test set reads: 53998 to 54002?	N/A YES: Go to Step 5.10 NO: Replace RT
5.10 Set RT CHAN to 3 Press PTT and test set Push-To-Test	N/A Test set reads: 74998 to 75002?	N/A YES: Go to Step 5.11 NO: Replace RT

STEPS TO PERFORM	CHECKS TO MAKE	ACTIONS TO TAKE
5.11 Set RT FCTN to RXMT, connect HS to RT RXMT, and listen at HS	Rushing noise heard at HS?	YES: Go to Step 5.12 NO: Replace RT
5.12 Press PTT	SIG display reads 4 or more?	YES: Go to STEP 6 NO: Replace RT

\* If unit SOP or tactical situation prohibits transmitting, use dummy load and realize that antenna cannot be checked.

\*\* If radio is used for data transmission, use 1/4 rather than 1/3 for these checks

**STEP 6. RECEIVER CHECKS:**

STEPS TO PERFORM	CHECKS TO MAKE	ACTIONS TO TAKE
6.1 Remove vehicular antenna cable from test set ANT Set test set MODE to SENS SQ Set RT: COMSEC to PT CHAN to 3	N/A N/A N/A N/A	N/A N/A N/A N/A
6.2 Press test set Push-To-Test	Test tone heard in HS?	YES: Go to Step 6.3 NO: Replace RT
6.3 Connect HS to RT AUD/FILL Set RT FCTN to SQ ON Press test set Push-To-Test	RT-A/B RT-A/B Test tone heard in HS?	N/A N/A YES: Go to STEP 7 NO: Replace RT

**STEP 7. POWER AMPLIFIER CHECKS:\***

STEPS TO PERFORM	CHECKS TO MAKE	ACTIONS TO TAKE
7.1 Connect vehicular antenna cable to test set ANT Connect W2/CG-3856 cable to RT ANT and PA J2 Set test set MODE to FWD PWR Connect test set cable from test set RADIO to PA J1 Set RT CHAN to 1	N/A N/A N/A N/A N/A	N/A N/A N/A N/A N/A
7.2 Press PTT and test set Push-To-Test	Test set reads 2-6 W FWD PWR?	YES: Go to Step 7.3 NO: Go to TS Chart 14
7.3 Set RT to PA Press PTT and test set Push-To-Test	N/A Test set reads 30 W or greater FWD PWR?	YES: Go to Step 7.4 NO: RT -A; Go to TS Chart 15 RT -B; Go to TS Chart 16
7.4 Set RT CHAN to 2 Press PTT and test set Push-To-Test	N/A Test set reads 30 W or greater FWD PWR?	N/A YES: Go to Step 7.5 NO: RT -A; Go to TS Chart 17 RT -B; Go to TS Chart 18

STEPS TO PERFORM	CHECKS TO MAKE	ACTIONS TO TAKE
7.5 Set RT CHAN to 3 Press PTT and test set Push-To-Test	N/A Test set reads 30 W or greater FWD PWR?	N/A YES: Go to Step 7.6 NO: RT-A; Go to TS Chart 17 RT- B; Go to TS Chart 18
7.6 Press PTT and count into HS	Sidetone heard at HS?	YES: Continue 4 NO: Replace PA
	SIG display reads 6?	YES: Go to STEP 8 NO: Go to TS Chart 19

\* Skip this STEP if the tactical situation or your unit SOP precludes transmitting.

3.1. OPERATIONAL CHECK. Continued

STEP 8. LS-671 CHECKS:

STEPS TO PERFORM	CHECKS TO MAKE	ACTIONS TO TAKE
8.1 Set test set MODE to FWD PWR Connect HS to LS-671 J2 Push LS-671 volume IN Set RT COMSEC to CT FCTN to TST MODE to SC RF PWR to HI	N/A N/A N/A N/A N/A N/A N/A N/A	N/A N/A N/A N/A N/A N/A N/A N/A
8.2 Check for beeps	Beeps heard at HS only?	YES: Go to Step 8.3 NO: Replace LS-671
8.3 Set RT COMSEC to PT FCTN to SQ ON Press PTT	N/A N/A RT SIG display reads 4 or more?	N/A N/A YES: Go to Step 8.4 NO: Go to TS Chart 20
8.4 Pull LS-671 volume OUT Press PTT and count into HS	N/A Sidetone heard at HS?	N/A YES: Continue - NO: Go to TS Chart 21
	Sidetone heard at LS-671?	YES: Replace LS-671 NO: End of Operational Check*

\* Return HS to operational position, if required.

**STEP 9. RCU/RT SELF-TEST:**

STEPS TO PERFORM	CHECKS TO MAKE	ACTIONS TO TAKE
9.1 Configure SIP/ASIP RT (RCU) and remoted RT for RCU operations	N/A	N/A
9.2 Set RCU FCTN to TST	RCU display reads GOOD for RCU self-test?	YES: Continue NO: Replace RCU
	RCU display then reads OPEN?	YES: Go to TS Chart 23 NO: Continue
	RCU display reads GOOD for RT self-test?	YES: Go to STEP 4 NO: Replace RT
9.3 Set RCU: FCTN to LD MODE to SC	N/A N/A	N/A N/A
9.4 RCU: Load SC frequencies: CHAN 1: 41000 CHAN 2: 54000 CHAN 3: 75000	N/A N/A N/A	N/A N/A N/A
9.5 Set RT: FCTN to LD MODE to SC	SC frequencies load in RT?	YES: Continue NO: Go to TS Chart 2 4
9.6 Set RT FCTN to REM	N/A	N/A
9.7 RCU: Press BATT/CALL pushbutton twice	RCU display reads (RT XX)?	YES: Go to STEP 9.8 NO: Replace RCU
9.8 Set RCU: FCTN to REM COMSEC to PT	N/A N/A	N/A N/A
9.9 RCU: Press BATT/CALL and PTT, and release	RCU display reads CALL?	YES: Go to Step 9.10 NO: Go to TS Chart 25
9.10 RCU: Press PTT and count into HS	Voice heard at AT?	YES: Go to Step 9.11 NO: Go to TS Chart 26
9.11 RT: Press BATT/CALL and PTT, and release	RT display reads CALL?	YES: Go to Step 9.12 NO: Go to TS Chart 27
9.12 RT: Press PTT and count into HS	Voice heard at RCU?	YES: Go to Step 9.13 NO: Go to TS Chart 28
9.13 RCU: Press BATT/CALL and PTT, and release	RCU display reads CALL?	YES: End of RCU Check NO: Go to TS Chart 25

(End of Operational Check for Vehicular Radios; See TS Chart 22 if having trouble with transmitting / receiving data devices.)

**Step 10. CDU CHECK:**

STEPS TO PERFORM	ACTIONS TO TAKE	CHECKS TO MAKE
10.1 Control Display Unit* : Connect CDU Vehicular Adapter Cable to AM-7239E connector J9  Connect CDU to CDU Vehicular Adapter Cable connector RTA	Install CDU.  N/A  N/A	N/A  N/A  N/A
10.2 Set RT A FCTN switch to STBY, then REM.	CDU display lights?	YES: Continue ↓ NO: Go to TS Chart 29.
	CDU passes self-test?	YES: Continue ↓ NO: Replace CDU.
10.3 Test all CDU features.	All features work?	YES: End of CDU Check. NO: Go to TS Chart 30.

\* CDU works in conjunction with handset H-250/U.





### **3.2. TROUBLESHOOTING FLOWCHARTS.**

This paragraph provides the unit maintainer with four general use schematics (Short Range RT-A; Short Range RT-B; Long Range RT-A; and Long Range RT-B) plus 30 Troubleshooting Charts. The unit maintainer is directed to one or more specific Troubleshooting Chart from the Operational Check. Use of Troubleshooting Charts prior to application of the Operational Check, represents poor use of unit maintainer time, can result in false pulls, and is strongly discouraged.

After application of the Operational Check and one or more Troubleshooting Charts, if required, the unit maintainer will perform the prescribed LRU replacement or repair. To ensure that the system is completely operational following such maintenance action, the unit maintainer again applies the complete Operational Check. If the system then passes all steps of the Operational Check, the system may be declared fully operational and returned to service.

3.2. TROUBLESHOOTING FLOWCHARTS. Continued

**Short Range Radio, RT-A  
(AN/VRC-87A/D/F, AN/VRC-88A/D/F)**

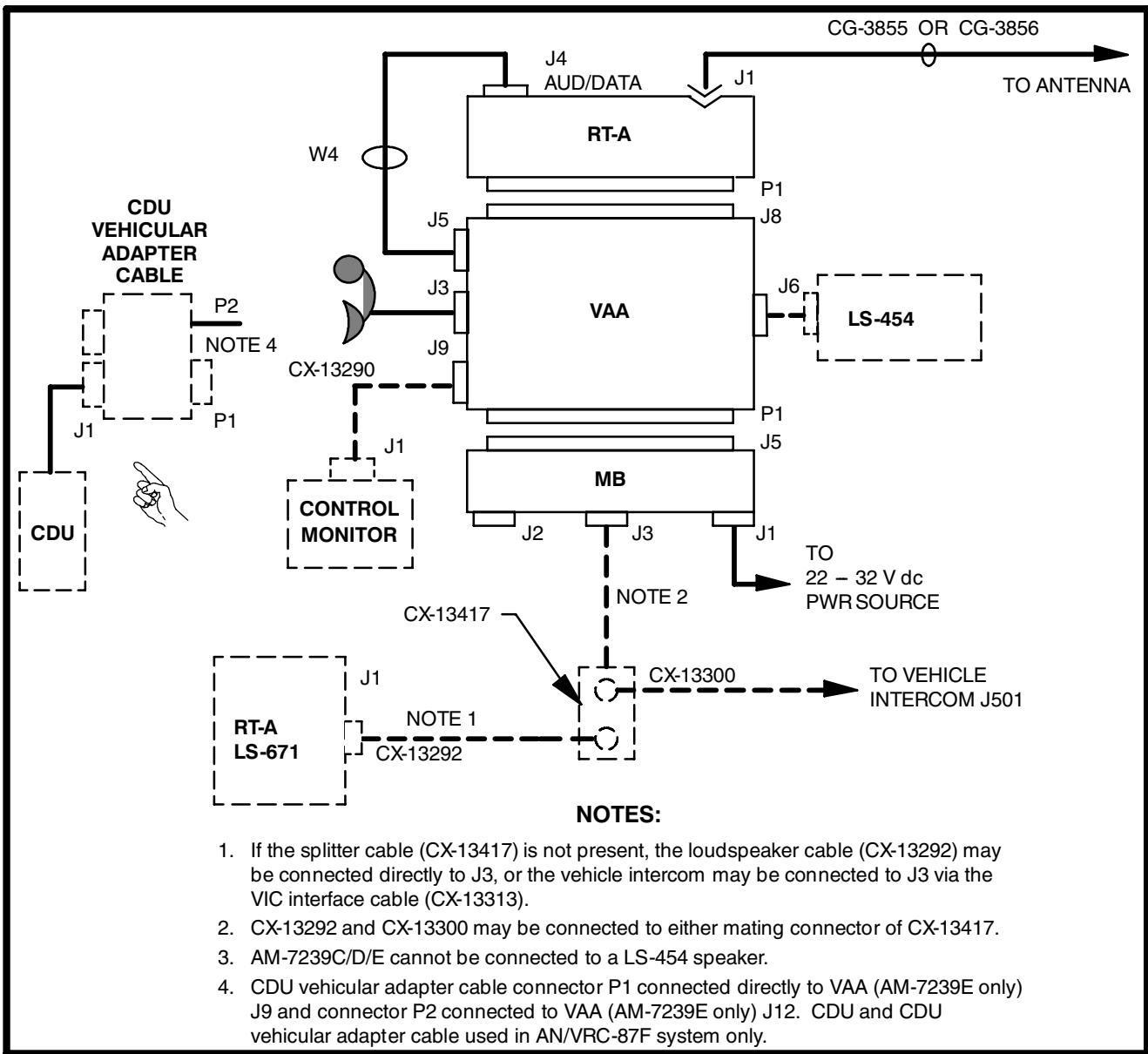

3.2. TROUBLESHOOTING FLOWCHARTS. Continued

**Short Range Radio, RT-B  
(AN/VRC-89A/D/F, AN/VRC-91A/D/F)**

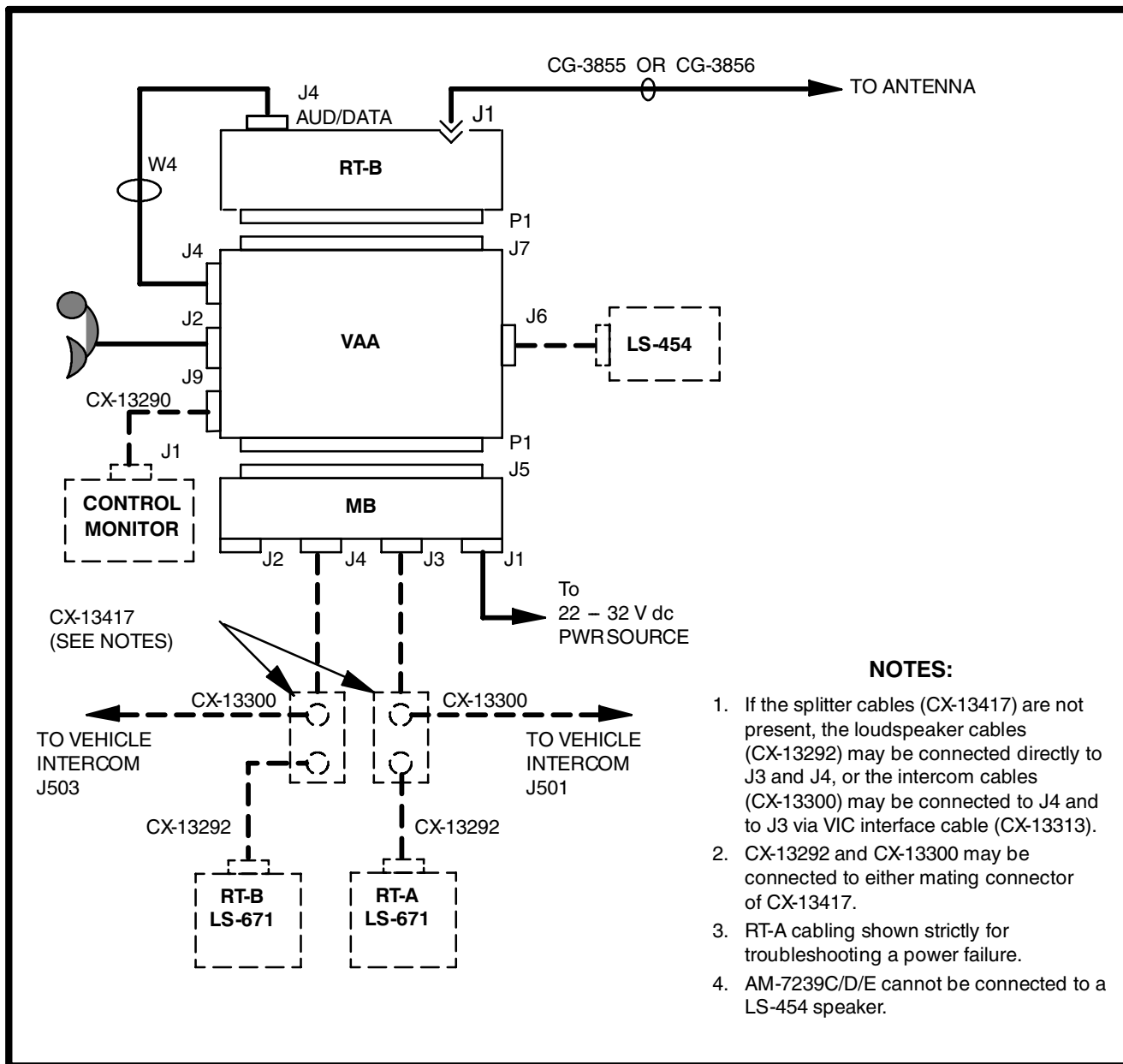

3.2. TROUBLESHOOTING FLOWCHARTS. Continued

**Long Range Radio, RT-A**  
**(AN/VRC-89A/D/F, AN/VRC-90A/D/F, AN/VRC-91A/D/F, AN/VRC-92A/D/F)**

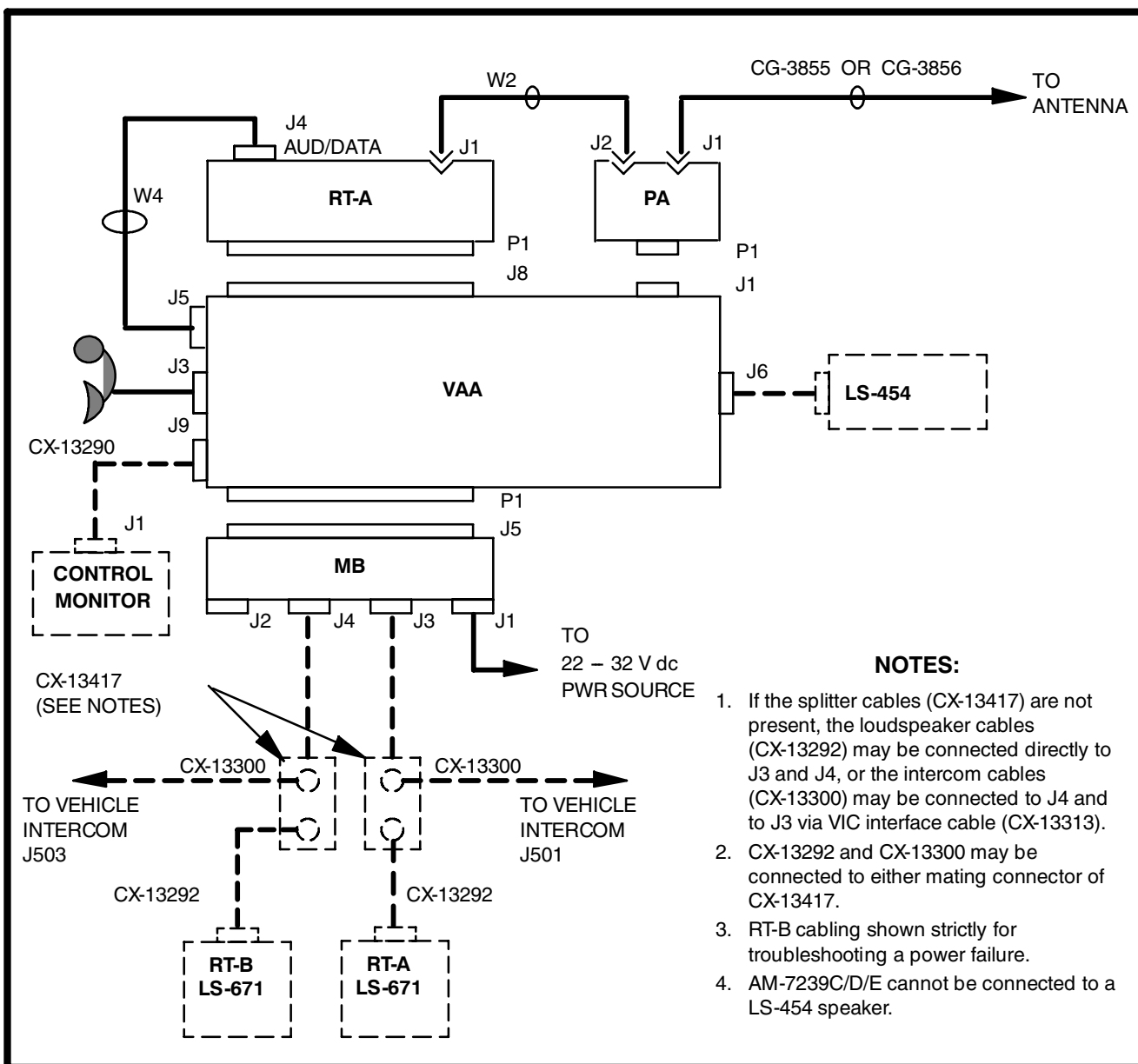

- NOTES:**
1. If the splitter cables (CX-13417) are not present, the loudspeaker cables (CX-13292) may be connected directly to J3 and J4, or the intercom cables (CX-13300) may be connected to J4 and to J3 via VIC interface cable (CX-13313).
  2. CX-13292 and CX-13300 may be connected to either mating connector of CX-13417.
  3. RT-B cabling shown strictly for troubleshooting a power failure.
  4. AM-7239C/D/E cannot be connected to a LS-454 speaker.

3.2. TROUBLESHOOTING FLOWCHARTS. Continued

**Long Range Radio, RT-B  
(AN/VRC-92A/D/F)**

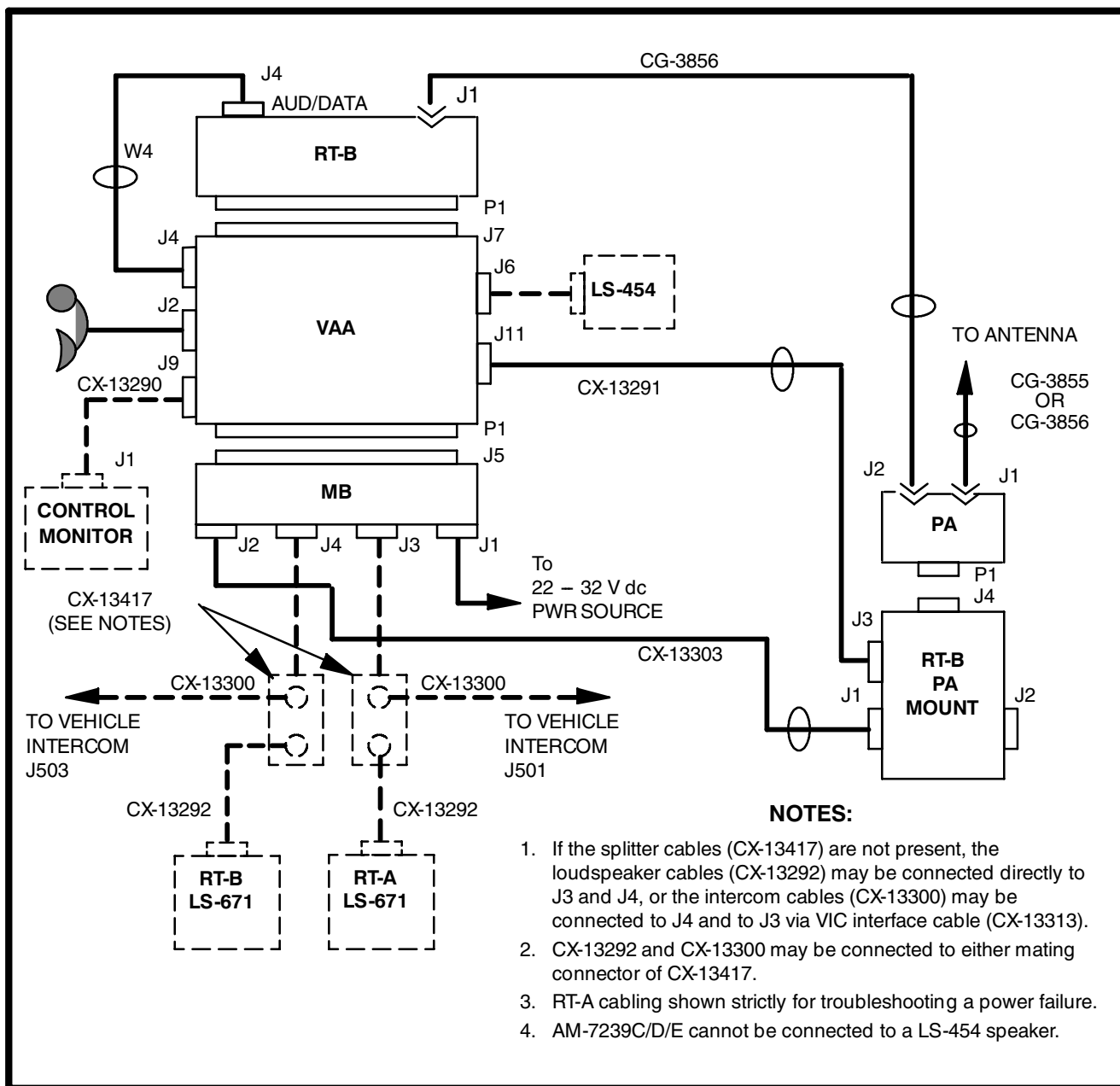

3.2. TROUBLESHOOTING FLOWCHARTS. Continued

Chart 1

VAA CB1 TRIPS WHEN SET TO "ON".  
(Sheet 1 of 2)

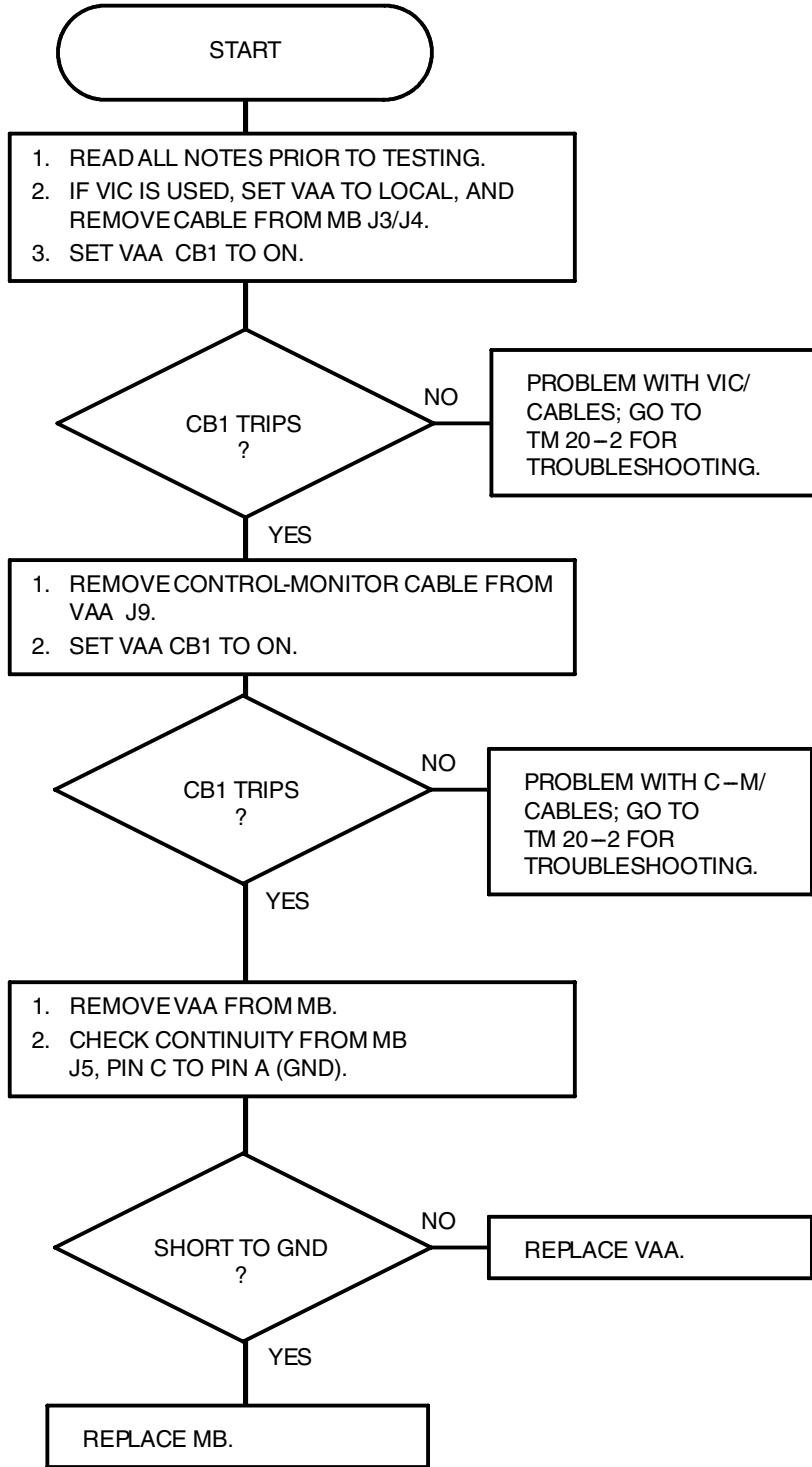

NOTES:

1. If a control-monitor is not installed, go to the next step.
2. If your system is an AN/VRC-89A, 90A, 91A, or 92A, the RT-A PA can trip the circuit breaker. Remove PA and set CB1 to ON and try again. If problem clears, RT-A PA is bad.
3. If your system has LS-671 loudspeakers, set VAA to LOCAL mode and remove all cables from MB J3/J4. Set CB1 to ON. If problem clears, go to:

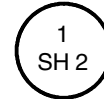

4. If your system has RT-B PA mount, disconnect cable from J2. If problem clears, go to:

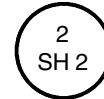

5. ● filled-in indicates male connector  
○ not filled-in indicates female connector

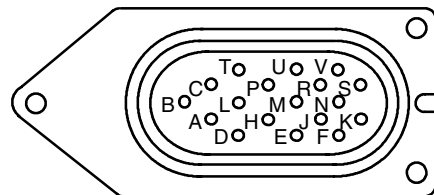

MB J5

3.2. TROUBLESHOOTING FLOWCHARTS. Continued

Chart 1

VAA CB1 TRIPS WHEN SET TO "ON".  
(Sheet 2 of 2)

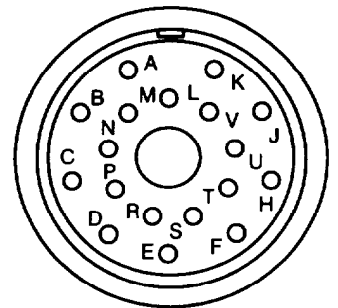
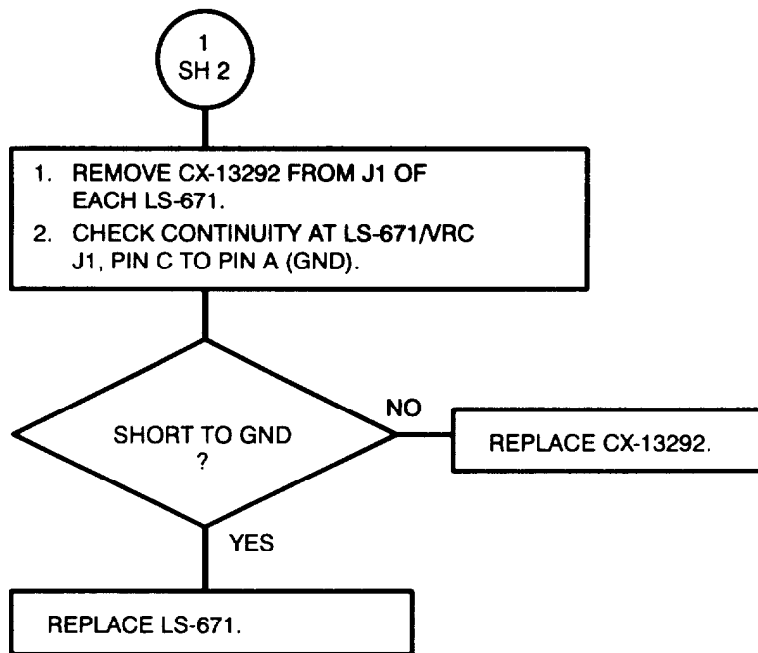

LS-671 J1

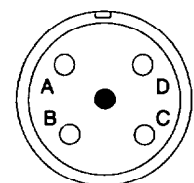
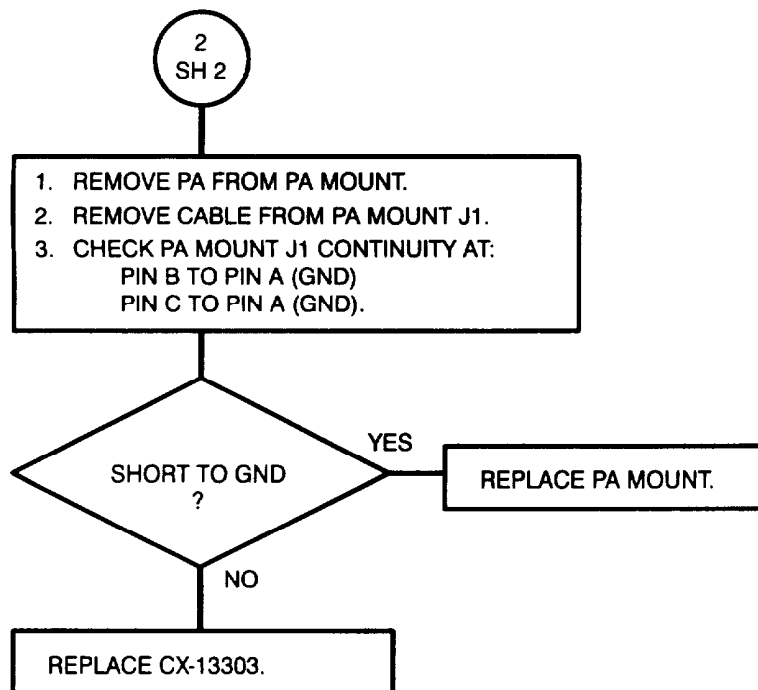

PA J1

3.2. TROUBLESHOOTING FLOWCHARTS. Continued

Chart 2

VAA DS1 NOT LIT WHEN CB1 IS SET TO "ON".

(Sheet 1 of 4)

NOTES:

1. Make sure VAA DS1 is set full CCW.
2. If CX-13292, CX-13313, or CX-13417 is used, ensure VAA is set to REMOTE.
3. If nothing is connected to MB J3/J4, ensure VAA is set to LOCAL.

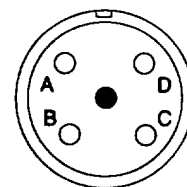
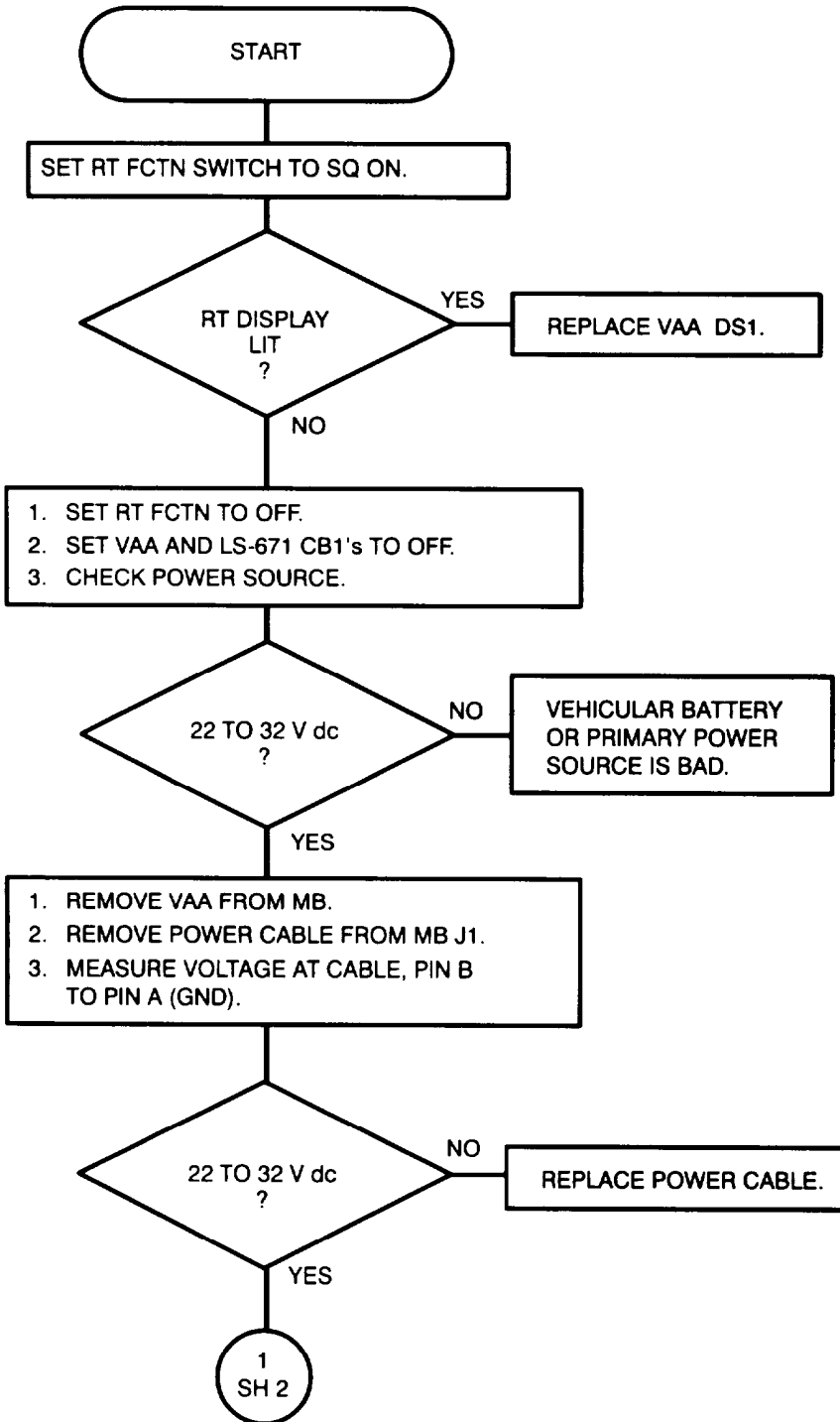

CX-13303



3.2. TROUBLESHOOTING FLOWCHARTS. Continued

Chart 2  
VAA DS1 NOT LIT WHEN CB1 IS SET TO 'ON'.  
(Sheet 2 of 4)

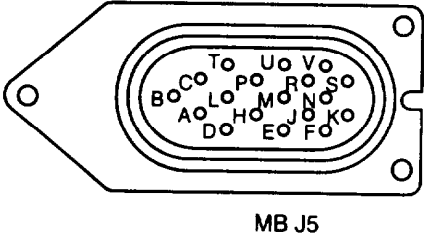
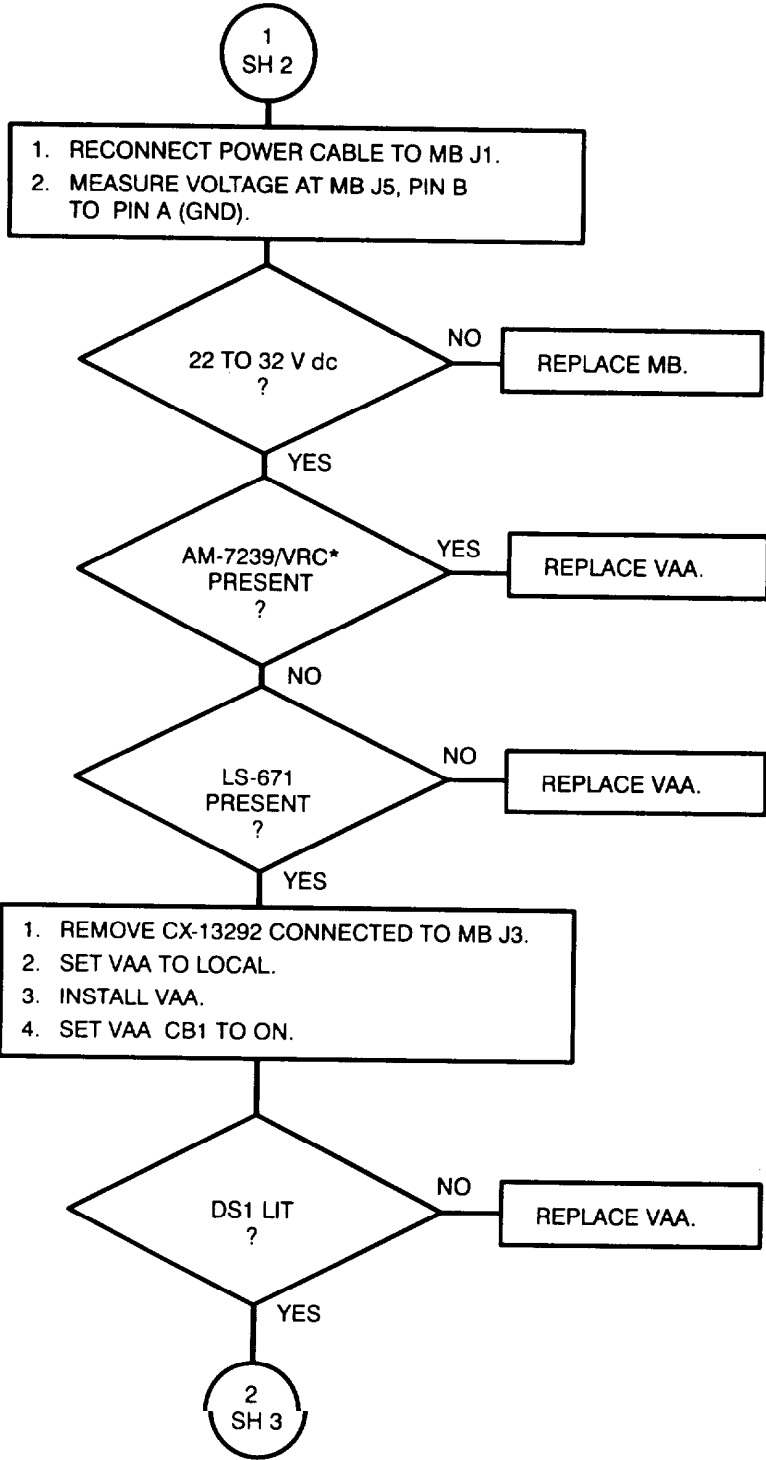

\* Not AM-7239A or AM-7239B,

3.2. TROUBLESHOOTING FLOWCHARTS. Continued

Chart 2

VAA DS1 NOT LIT WHEN CB1 IS SET TO "ON".

(Sheet 3 of 4)

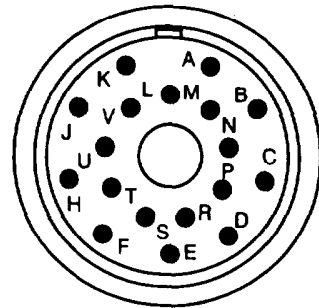
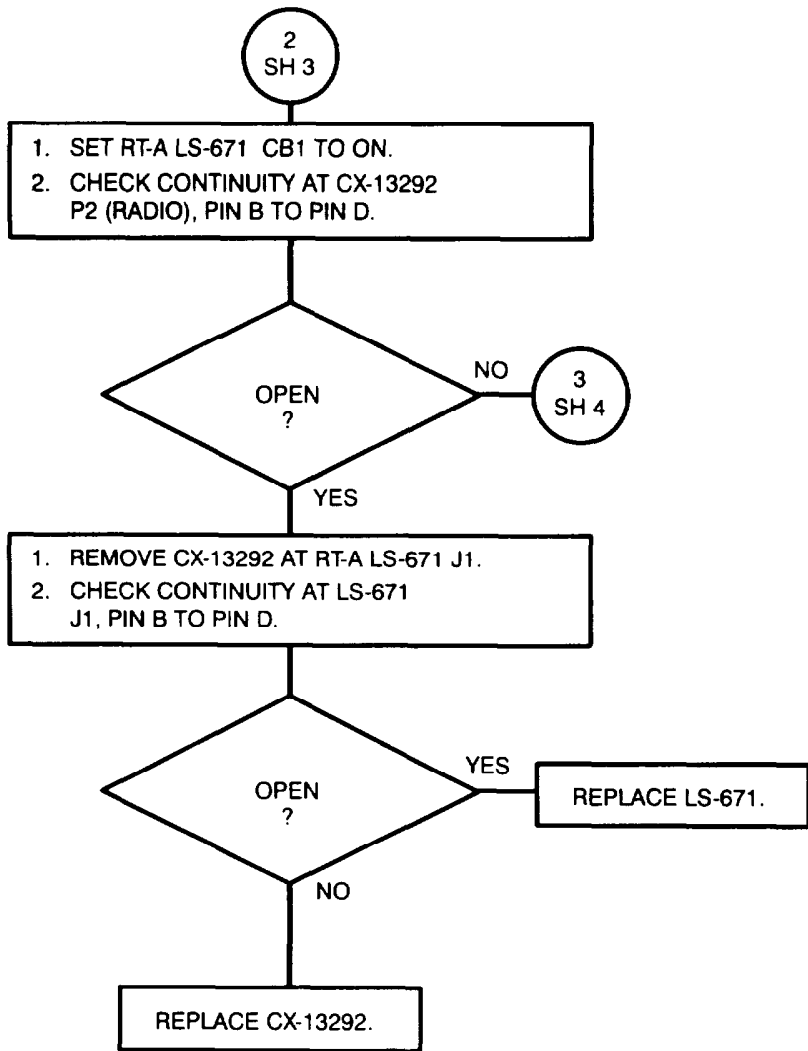

CX-13292 P2

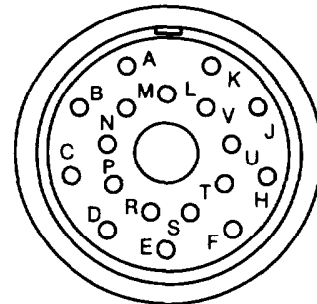

LS-671 J1

3.2. TROUBLESHOOTING FLOWCHARTS. Continued

Chart 2

VAA DS1 NOT LIT WHEN CB1 IS SET TO "ON".

(Sheet 4 of 4)

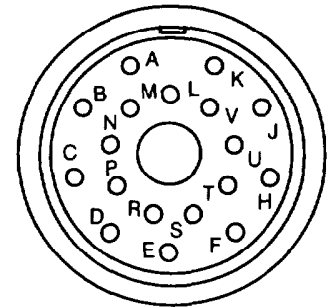
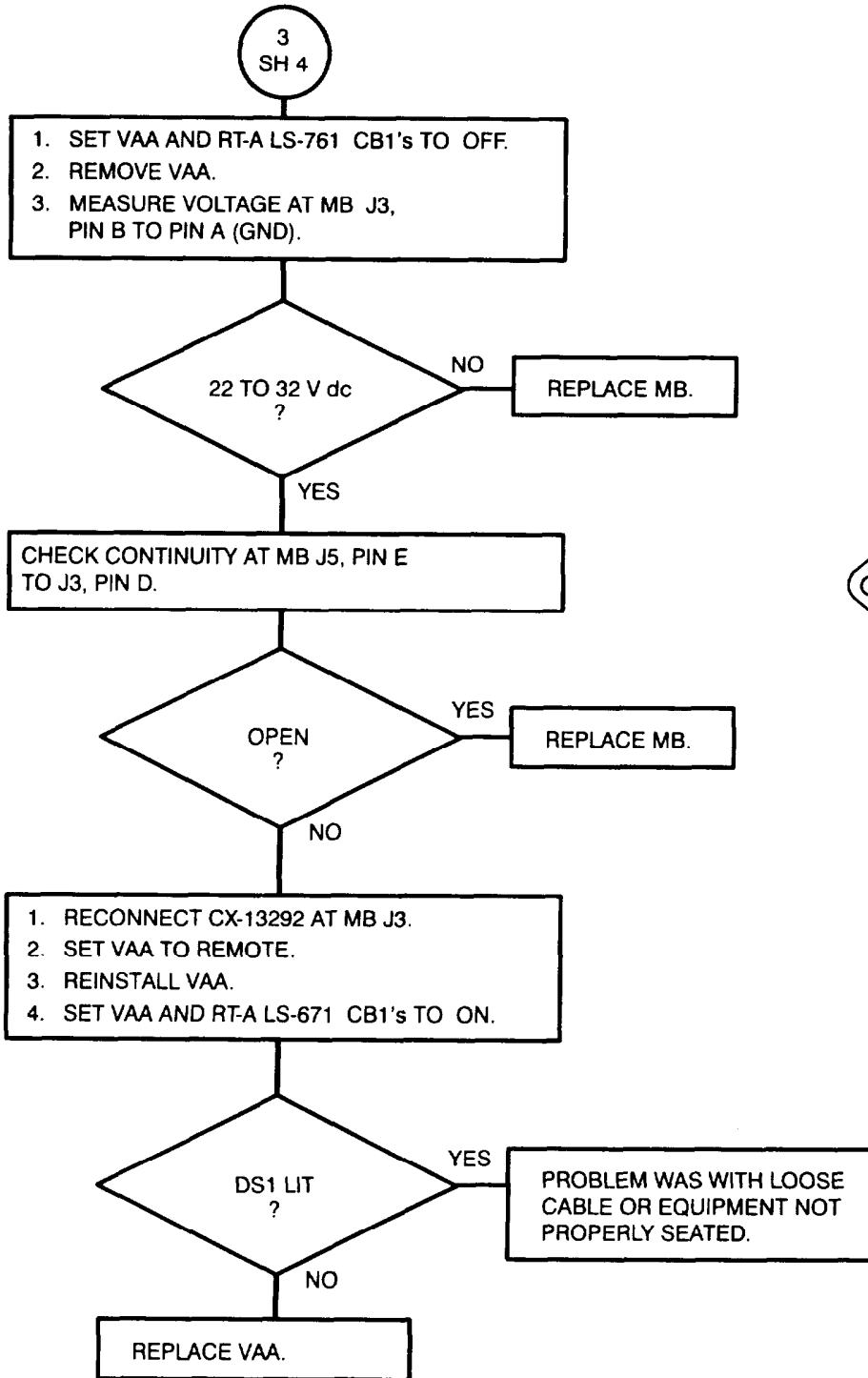

MB J3

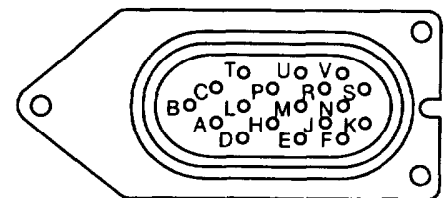

MB J5

3.2. TROUBLESHOOTING FLOWCHARTS. Continued

Chart 3

RT-A LS-671 DS1 NOT LIT AND VAA DS1 IS LIT.  
(Sheet 1 of 4)

**NOTE:**  
Make sure LS-671 DS1 is set full CCW.

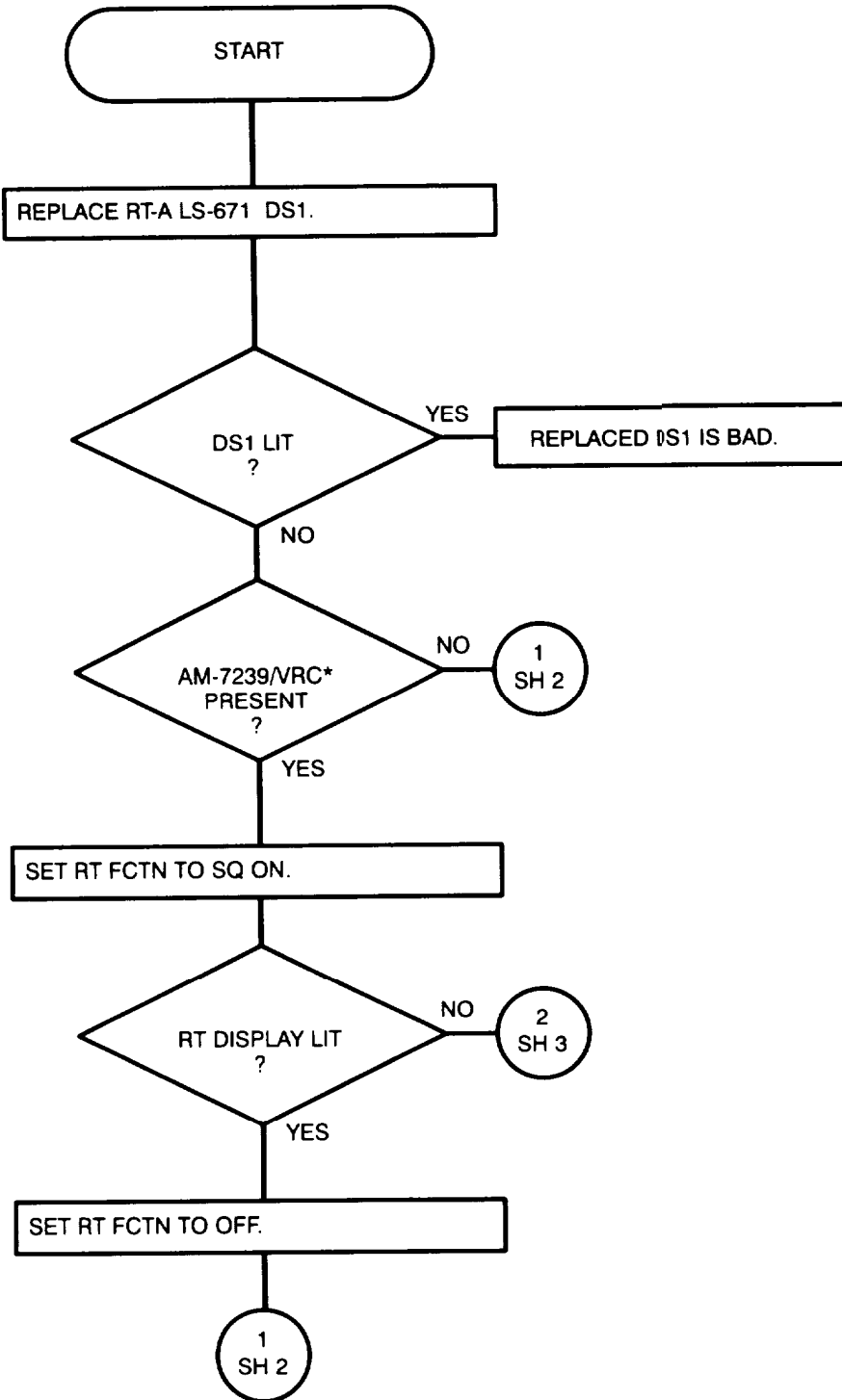

\* Not AM-7239AJB/C/DIE.

3.2. TROUBLESHOOTING FLOWCHARTS. Continued

Chart 3

RT-A LS-671 DS1 NOT LIT AND VAA DS1 IS LIT.  
(Sheet 2 of 4)

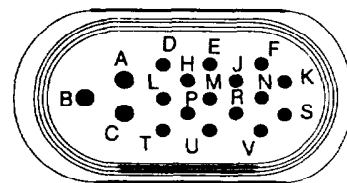
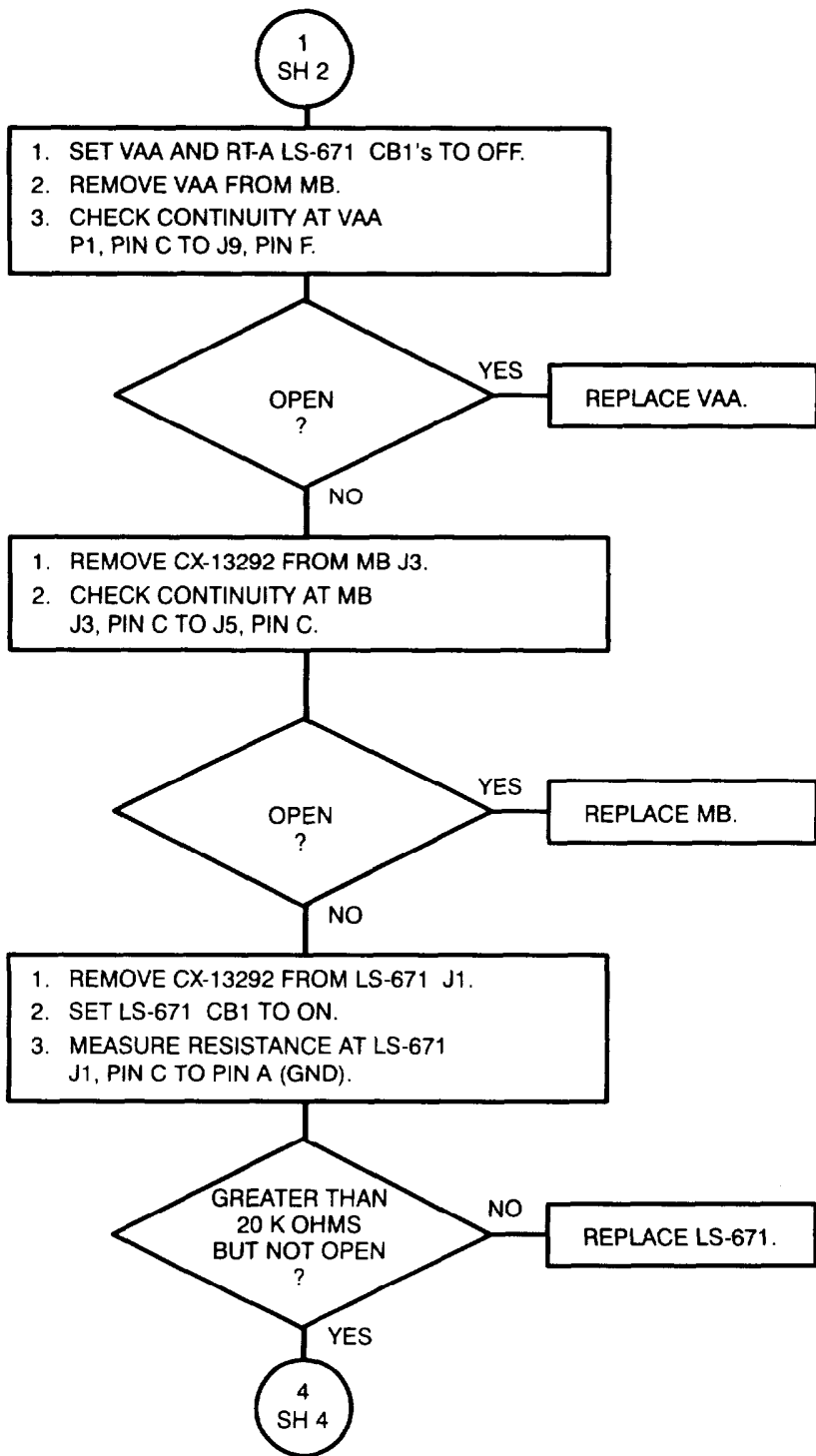

VAA P1

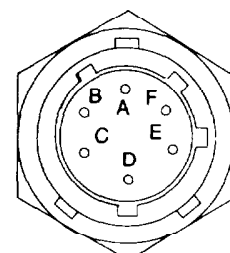

VAA J9

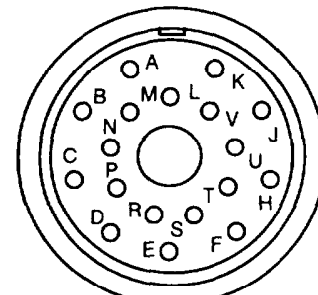

MB J3

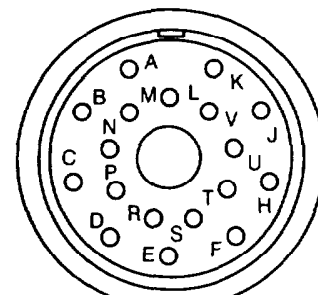

LS-671 J1

3.2. TROUBLESHOOTING FLOWCHARTS. Continued

Chart 3

RT-A LS-671 DS1 NOT LIT AND VAA DS1 IS LIT.

(Sheet 3 of 4)

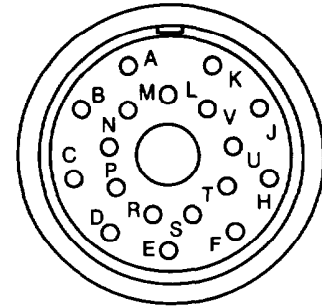
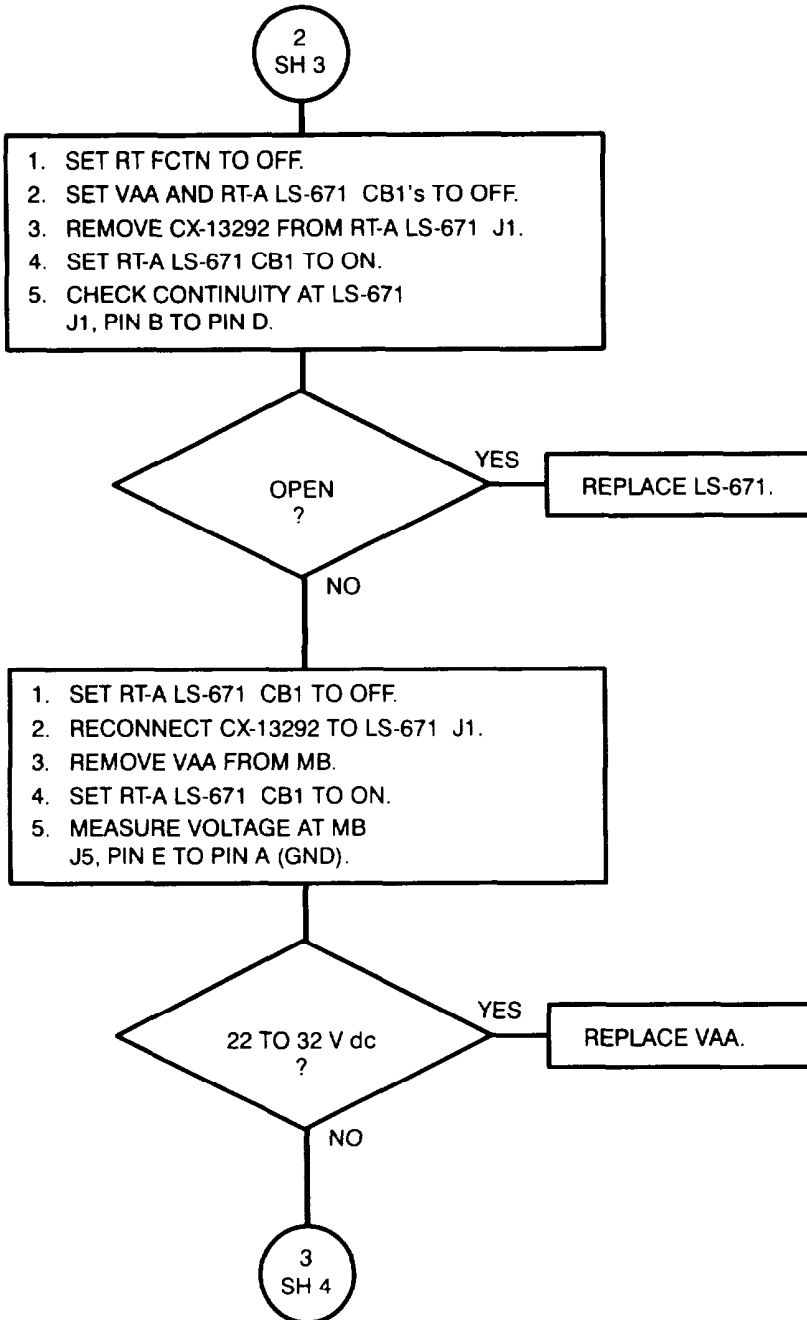

LS-671 J1

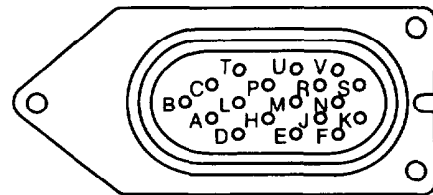

MB J5

3.2. TROUBLESHOOTING FLOWCHARTS. Continued

Chart 3

RT-A LS-671 DS1 NOT LIT AND VAA DS1 IS LIT.  
(Sheet 4 of 4)

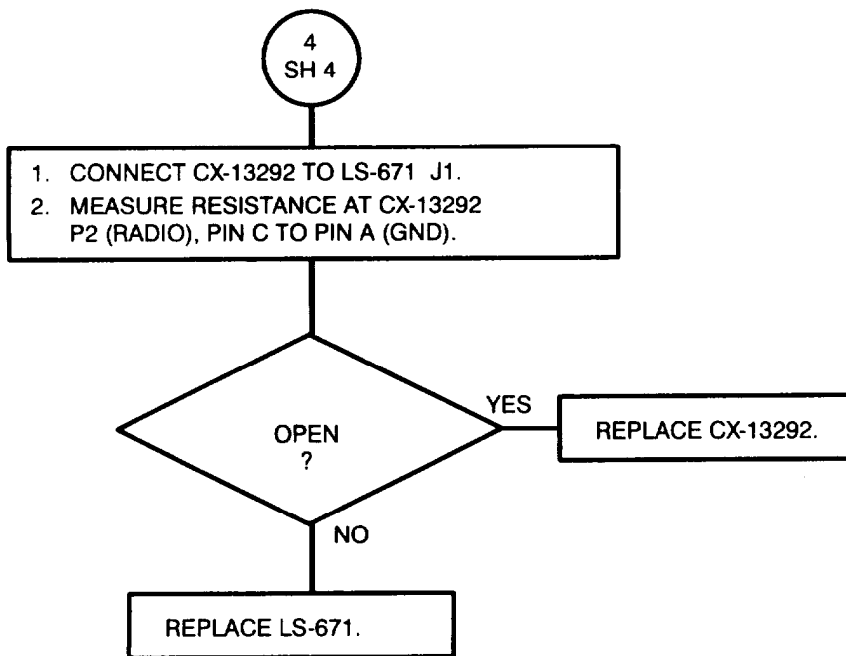
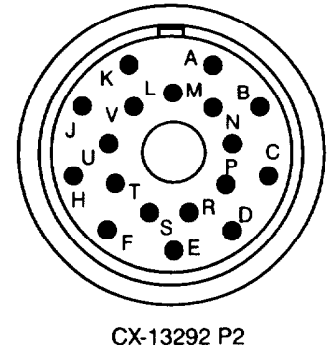
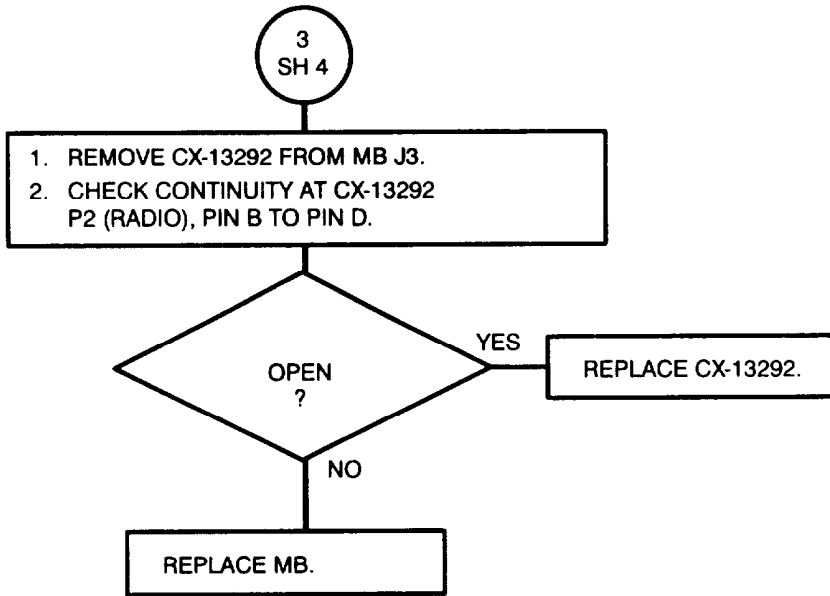

3.2. TROUBLESHOOTING FLOWCHARTS. Continued

Chart 4

NO REMOTE POWER FROM RT-B LS-671.  
(Sheet 1 of 3)

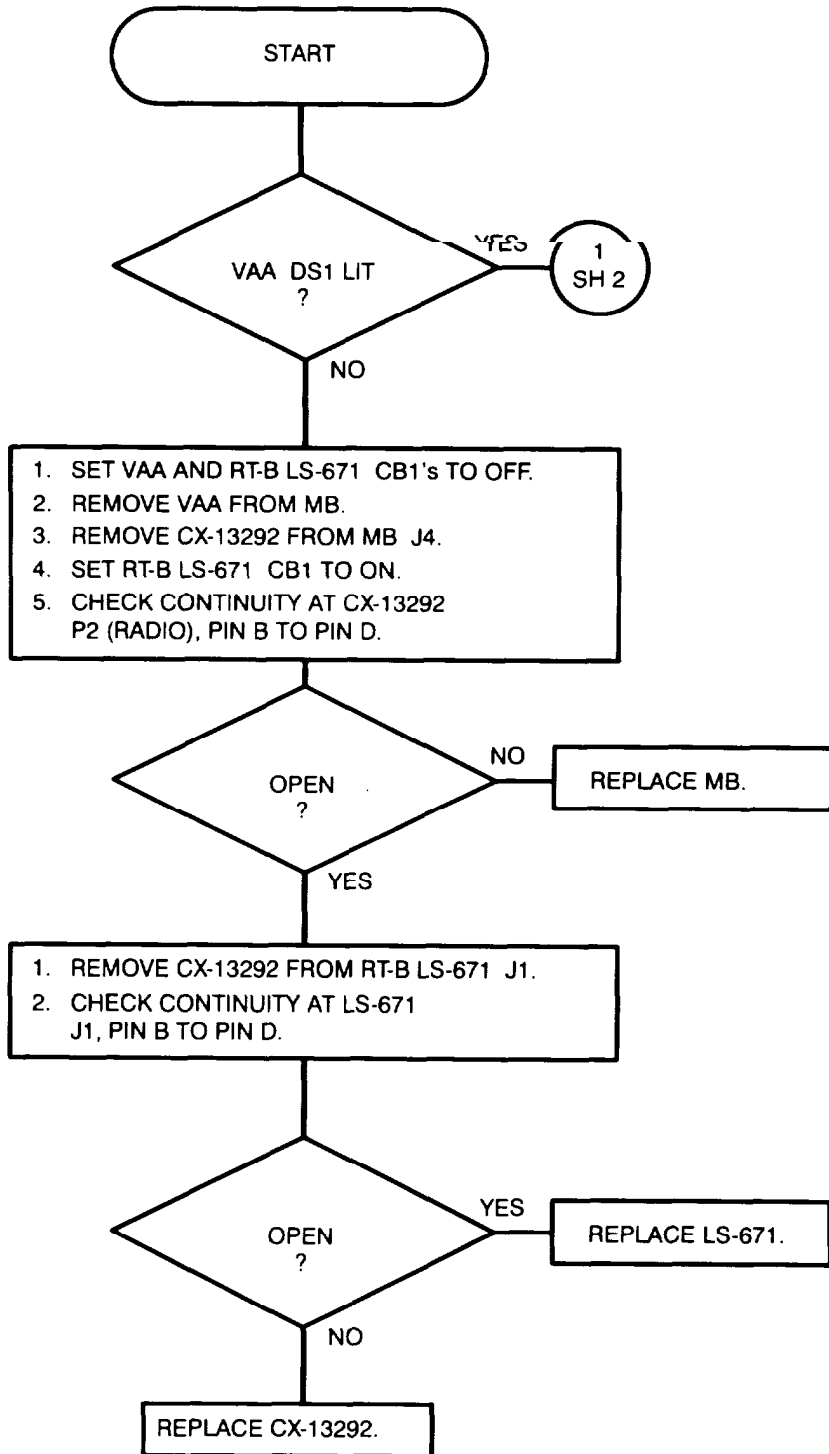

NOTE:

Make sure LS-671 DS1 is set full CCW.

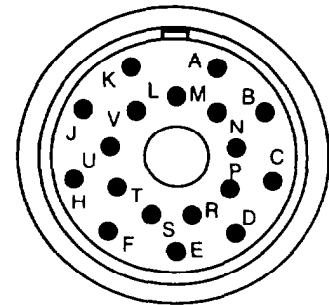

CX-13292 P2

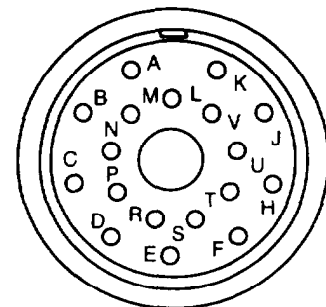

LS-671 J1



3.2. TROUBLESHOOTING FLOWCHARTS. Continued

Chart 4

NO REMOTE POWER FROM RT-B LS-671.

(Sheet 2 of 3)

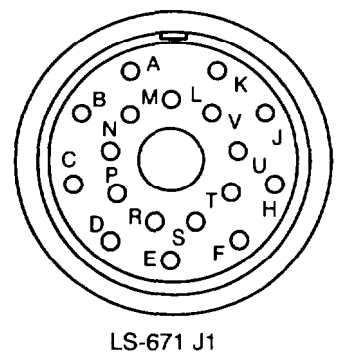
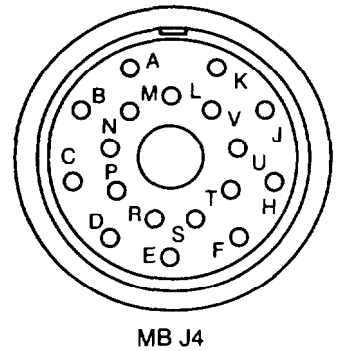
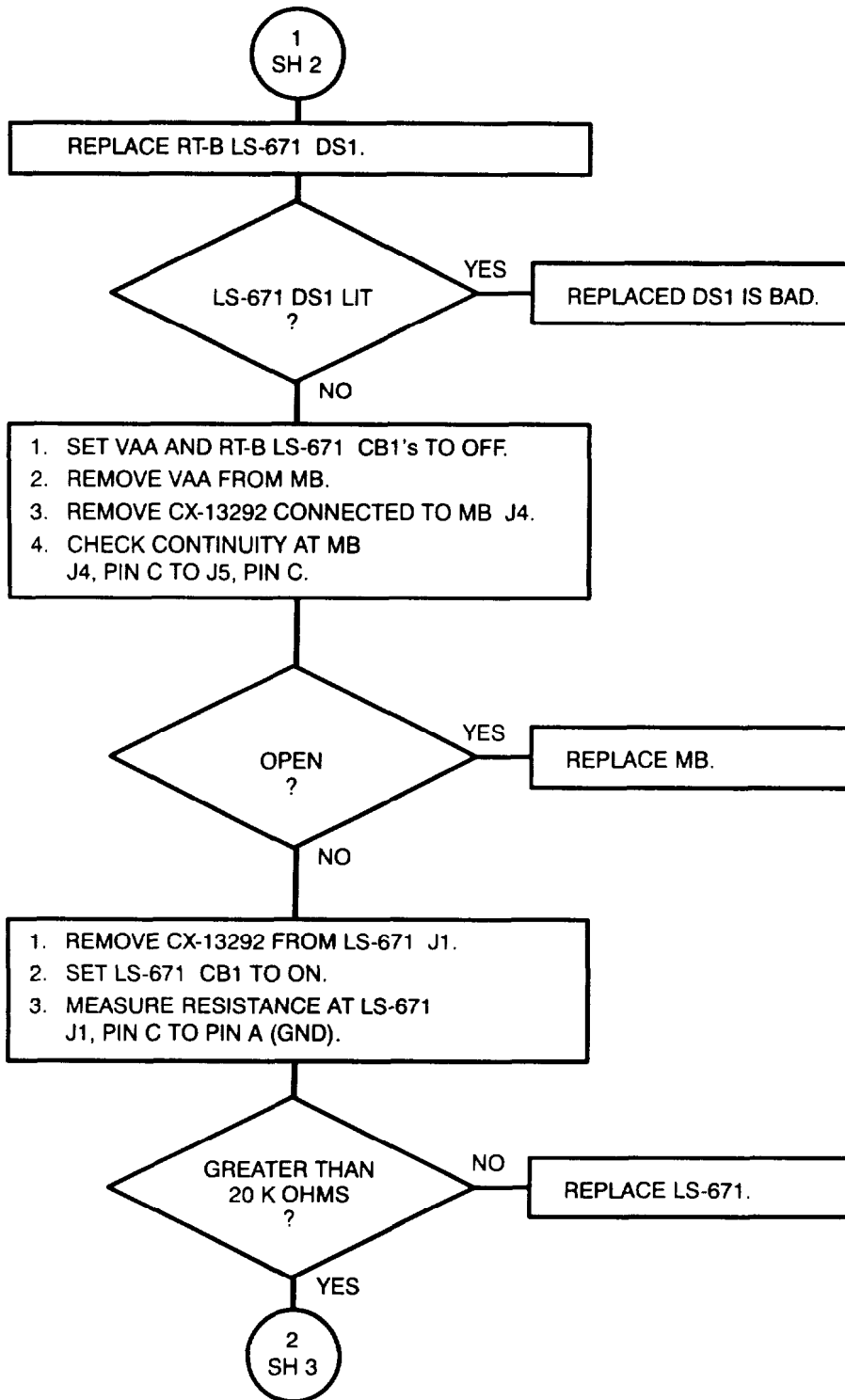

3.2. TROUBLESHOOTING FLOWCHARTS. Continued

Chart 4

NO REMOTE POWER FROM RT-B LS-671.  
(Sheet 3 of 3)

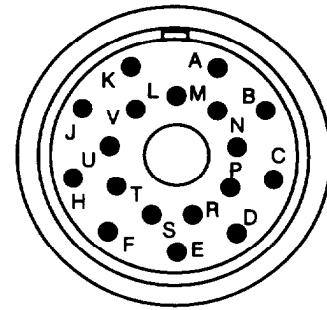
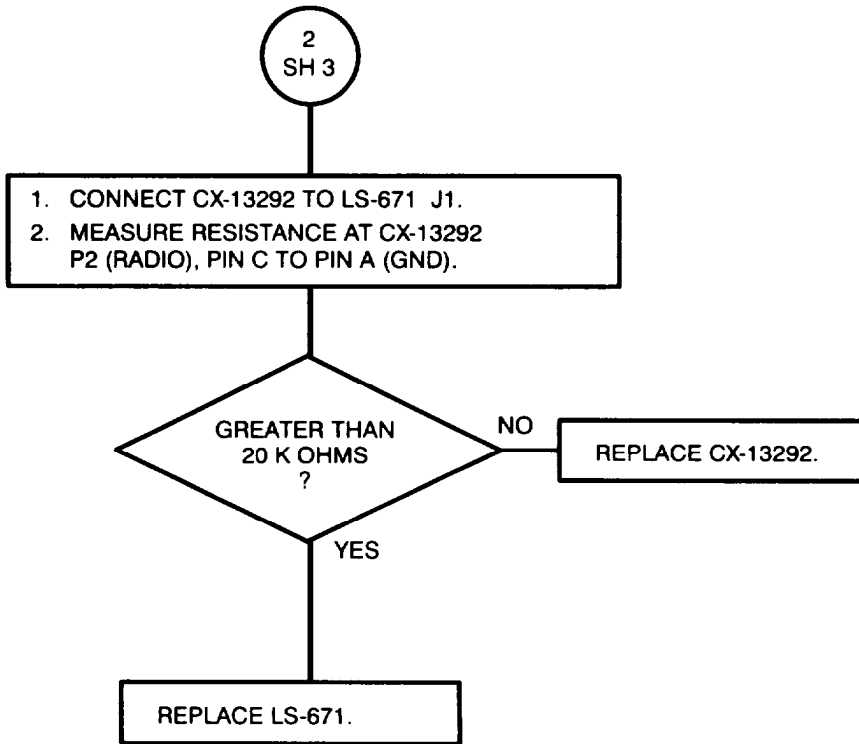

CX-13292 P2

3.2. TROUBLESHOOTING FLOWCHARTS. Continued

Chart 5

PA MOUNT CB1 TRIPS AND VAA DS1 IS LIT.  
(Sheet 1 of 1)

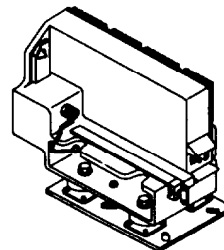
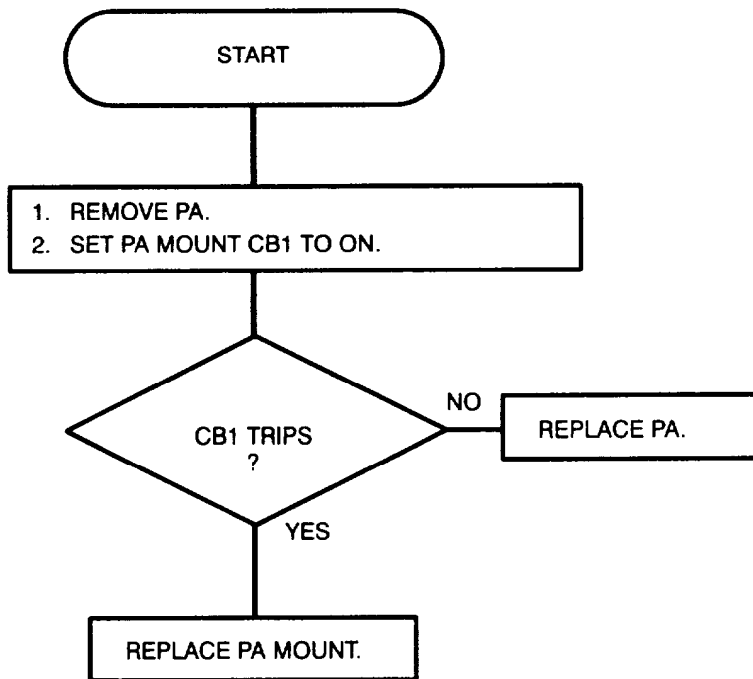

**MOUNTING BASE,  
ELECTRICAL EQUIPMENT  
(PA MOUNT)  
MT-6353/VRC**

3.2. TROUBLESHOOTING FLOWCHARTS. Continued

Chart 6

PA MOUNT DS1 NOT LIT AND VAA DS1 IS LIT.  
(Sheet 1 of 3)

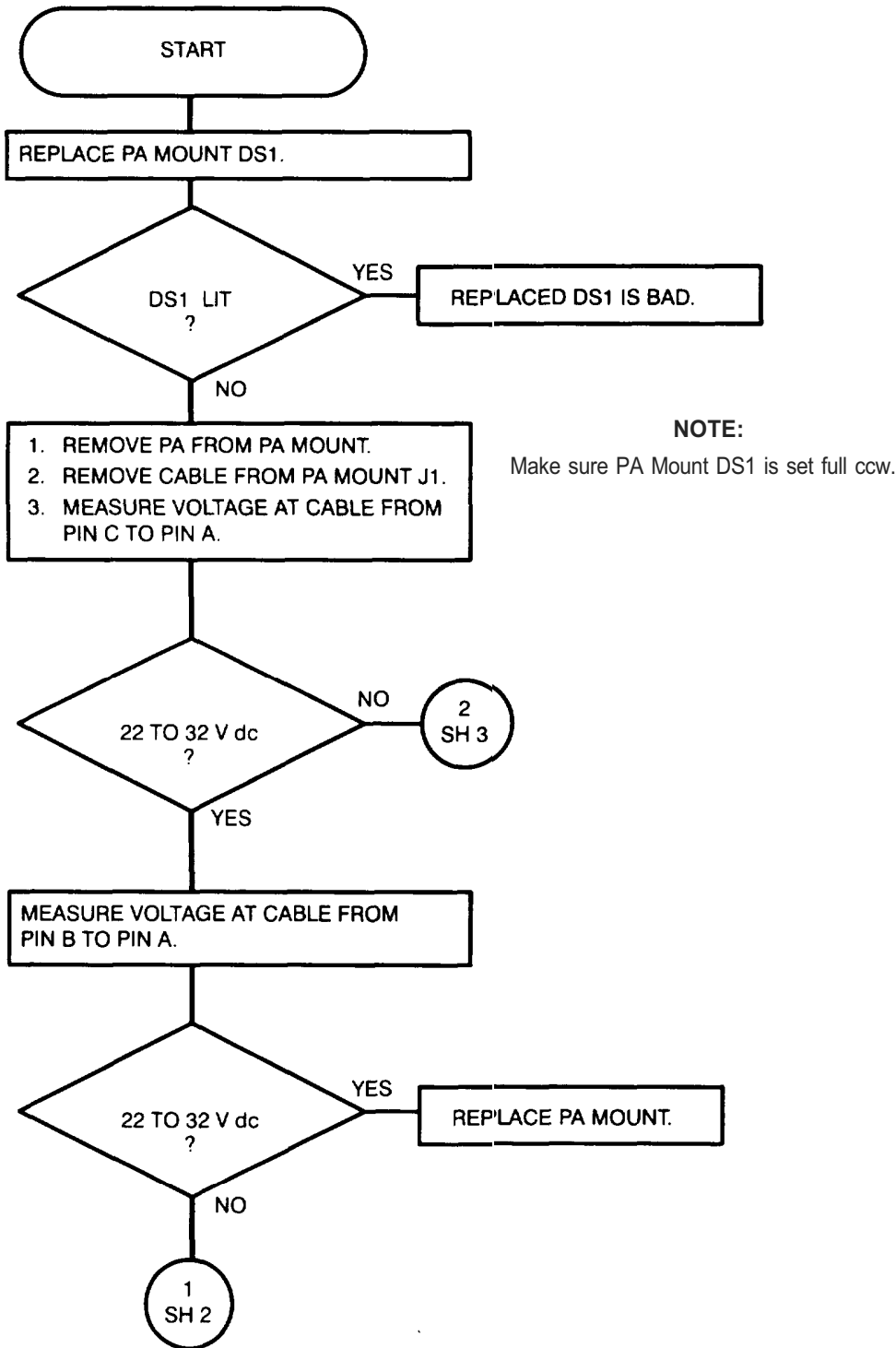

3.2. TROUBLESHOOTING FLOWCHARTS. Continued

Chart 6

PA MOUNT DS1 NOT LIT AND VAA DS1 IS LIT.

(Sheet 2 of 3)

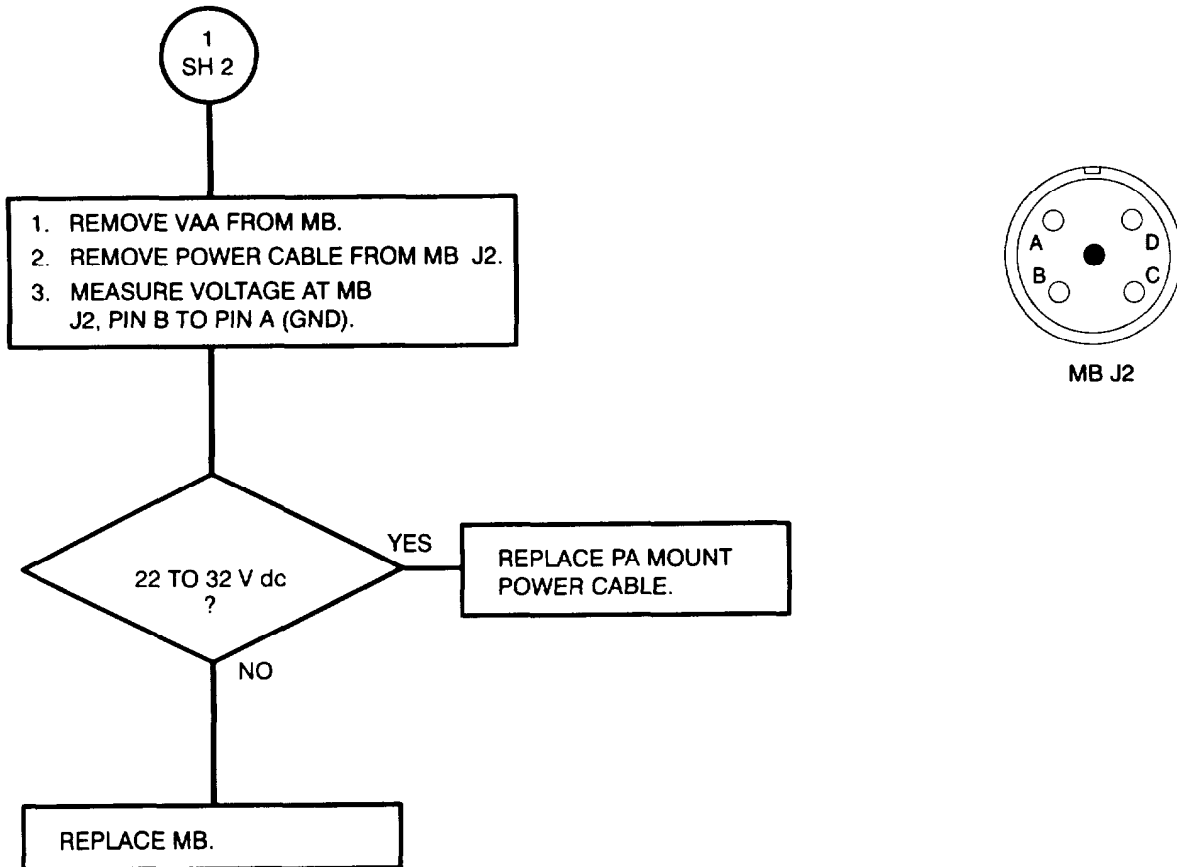

3.2. TROUBLESHOOTING FLOWCHARTS. Continued

Chart 6

PA MOUNT DS1 NOT LIT AND VAA DS1 IS LIT.  
(Sheet 3 of 3)

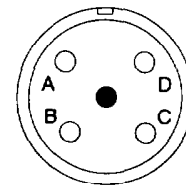
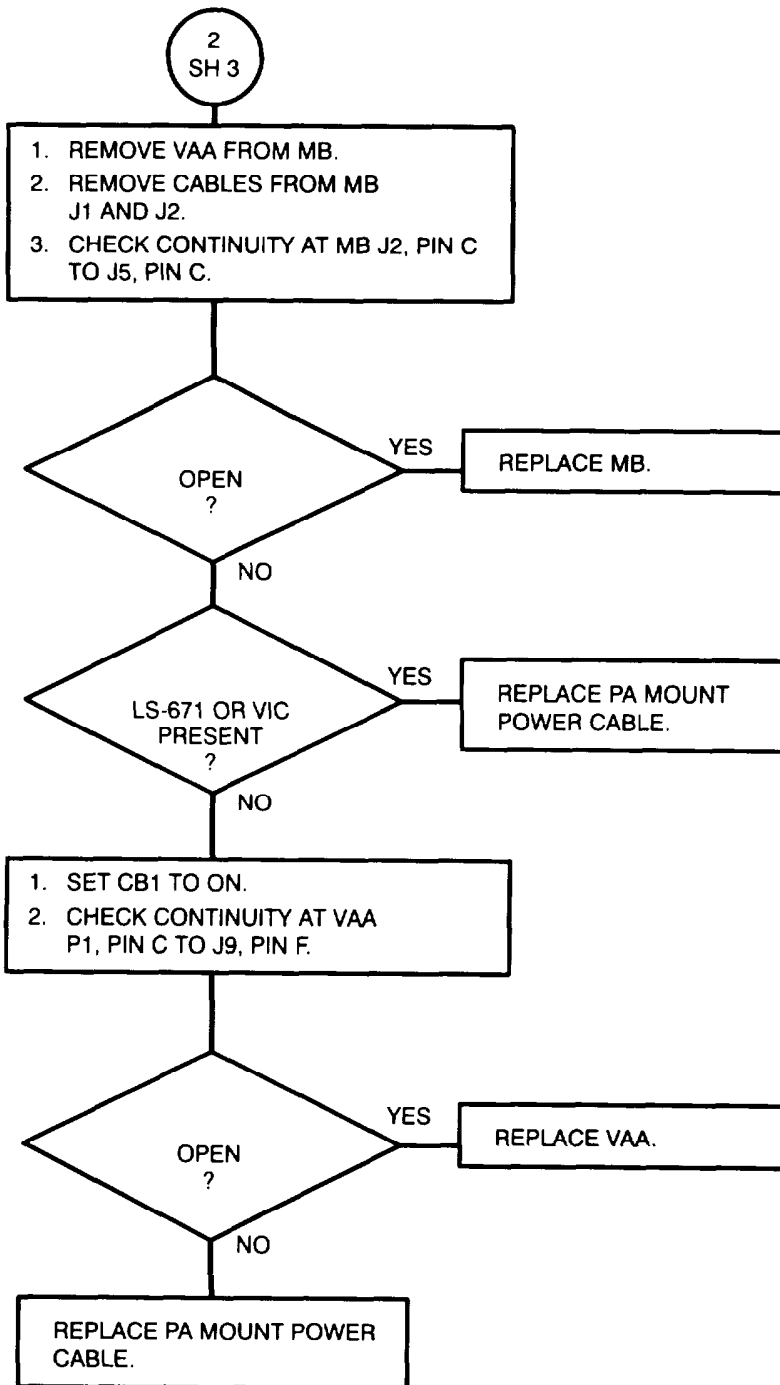

MB J2

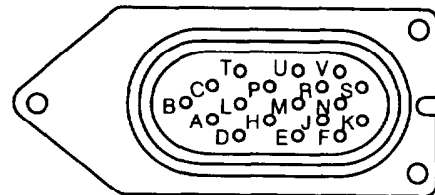

MB J5

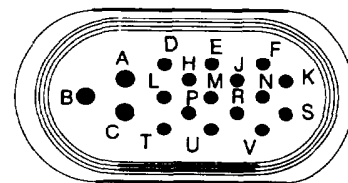

VAA P1

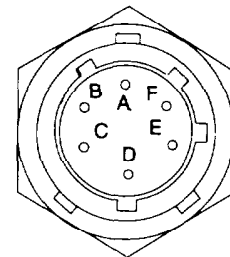

VAA J9

NOTE:

Ensure that the VAA is set for LOCAL operation.

3.2. TROUBLESHOOTING FLOWCHARTS. Continued

Chart 7

RT DISPLAY DOES NOT LIGHT AND VAA DS1 IS LIT.

(Sheet 1 of 1)

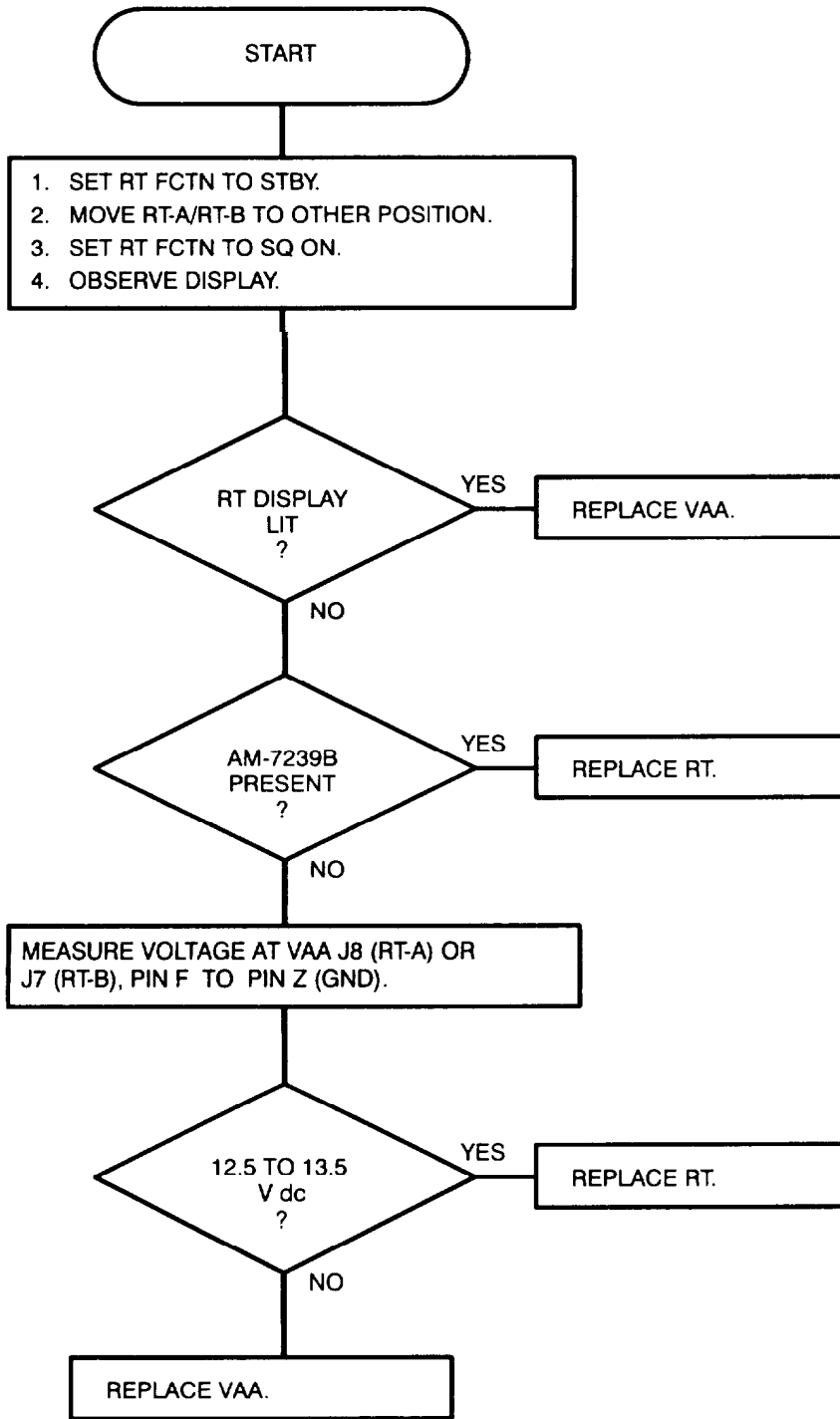

NOTE:

If VIC/LS-671 not present, ensure VAA is set to LOCAL.

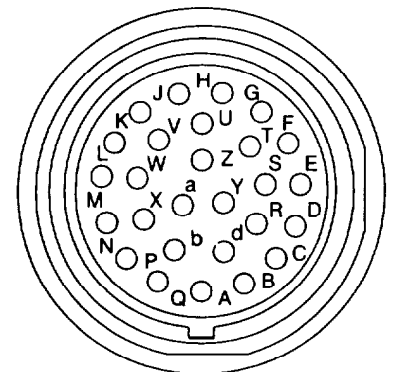

VAA J7/J8

3.2. TROUBLESHOOTING FLOWCHARTS. Continued

Chart 8

RT DISPLAY READS FAIL 6.

(Sheet 1 of 1)

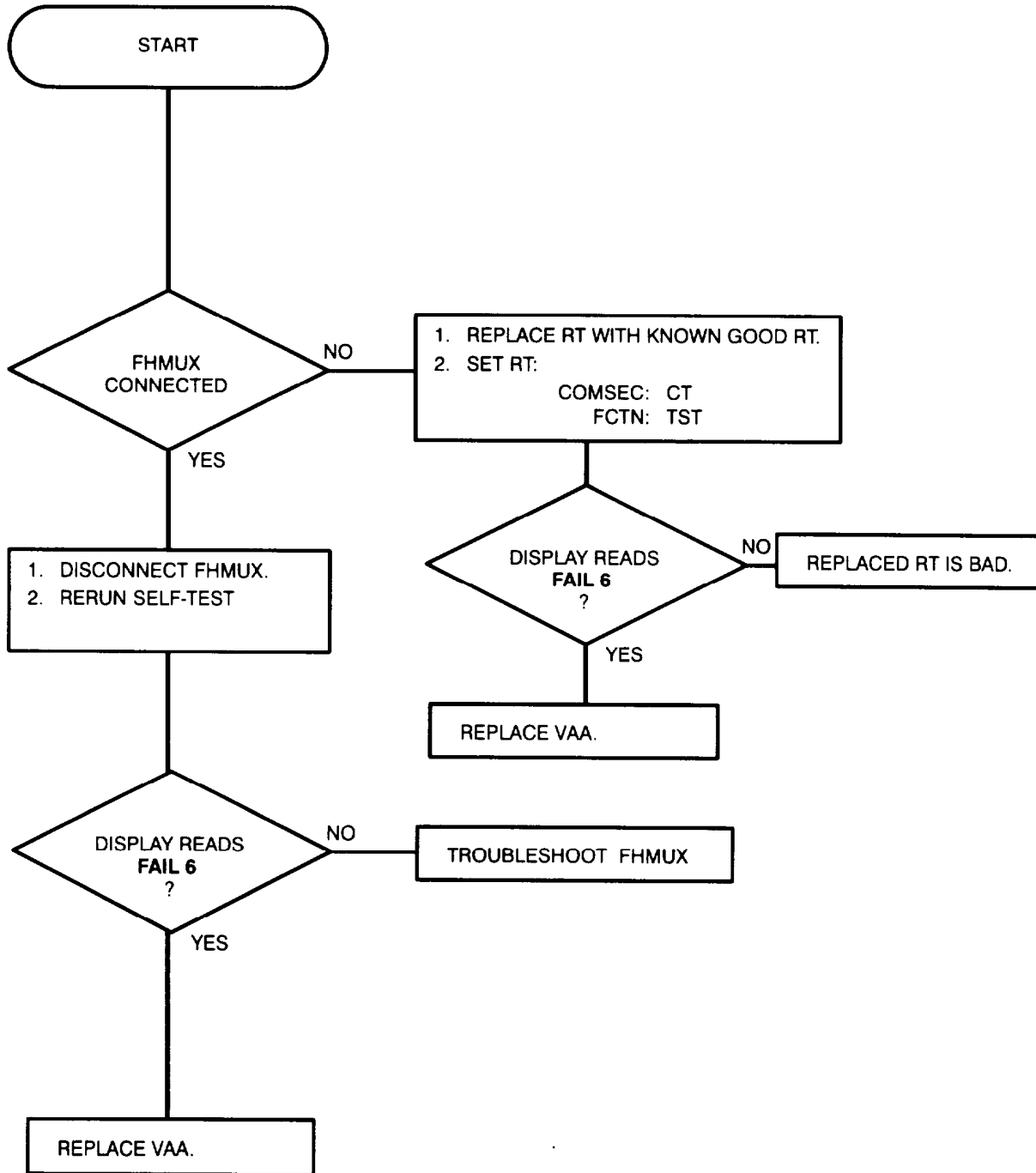



3.2. TROUBLESHOOTING FLOWCHARTS. Continued

Chart 9

COMSEC ALARM NOT HEARD AT HANDSET OR WILL NOT CLEAR  
(NO EXTERNAL DEVICE).

(Sheet 1 of 3)

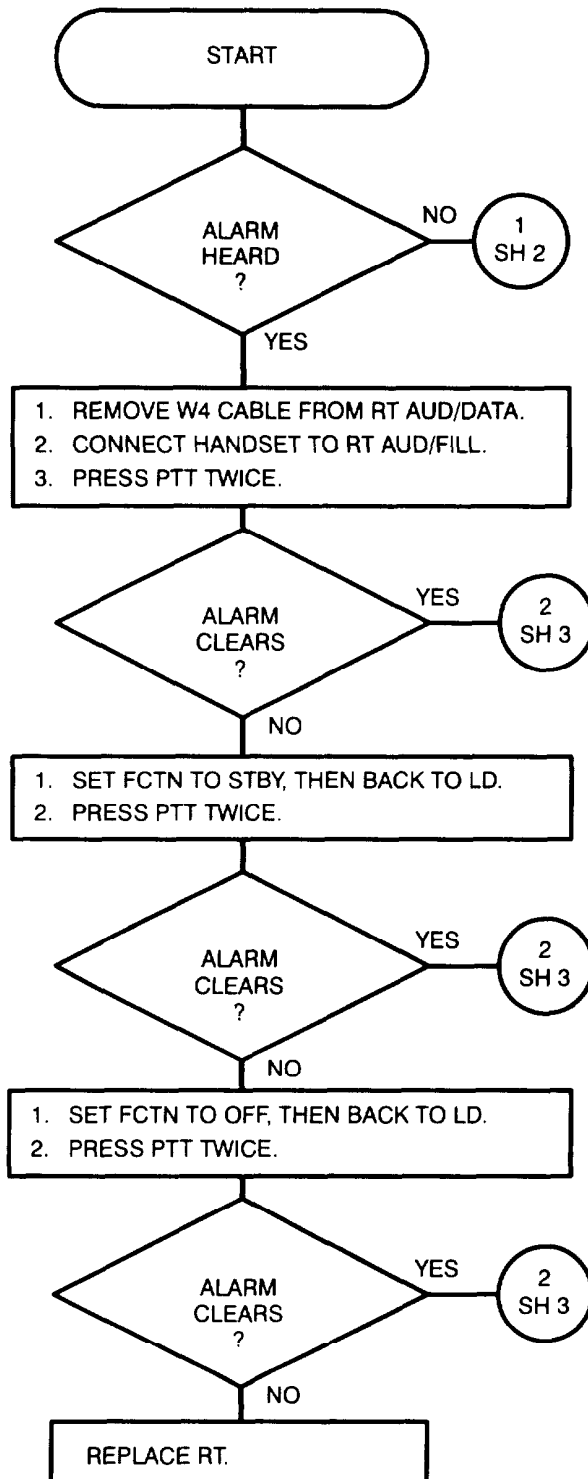

3.2. TROUBLESHOOTING FLOWCHARTS. Continued

Chart 9

COMSEC ALARM NOT HEARD AT HANDSET OR WILL NOT CLEAR  
(NO EXTERNAL DEVICE).

(Sheet 2 of 3)

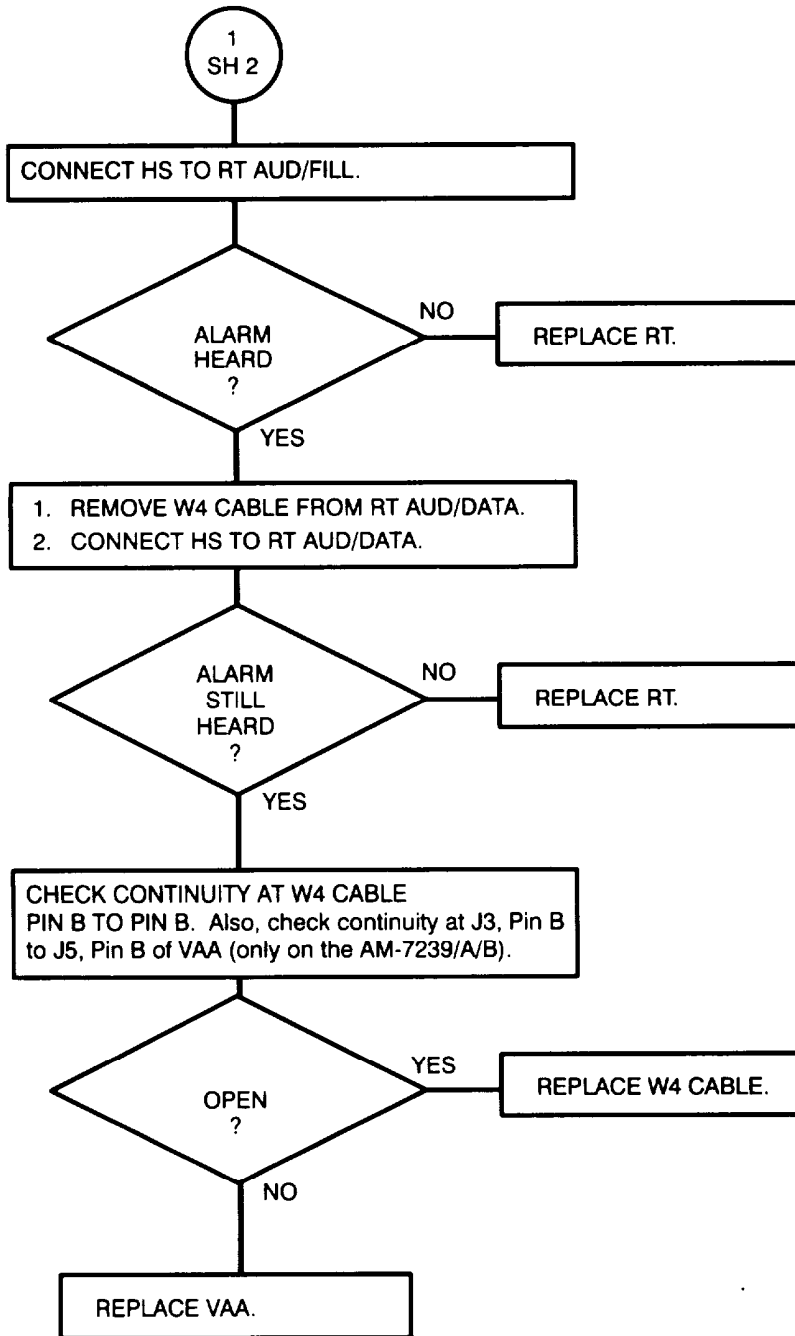

NOTE:

AM-7239C/D/E utilizes W4 only when passing packet data on tactical internet. Disregard W4 checks for normal troubleshooting.

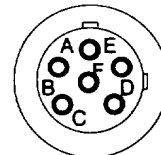

W4 P1/P2

3.2. TROUBLESHOOTING FLOWCHARTS. Continued

Chart 9

COMSEC ALARM NOT HEARD AT HANDSET OR WILL NOT CLEAR  
(NO EXTERNAL DEVICE).

(Sheet 3 of 3)

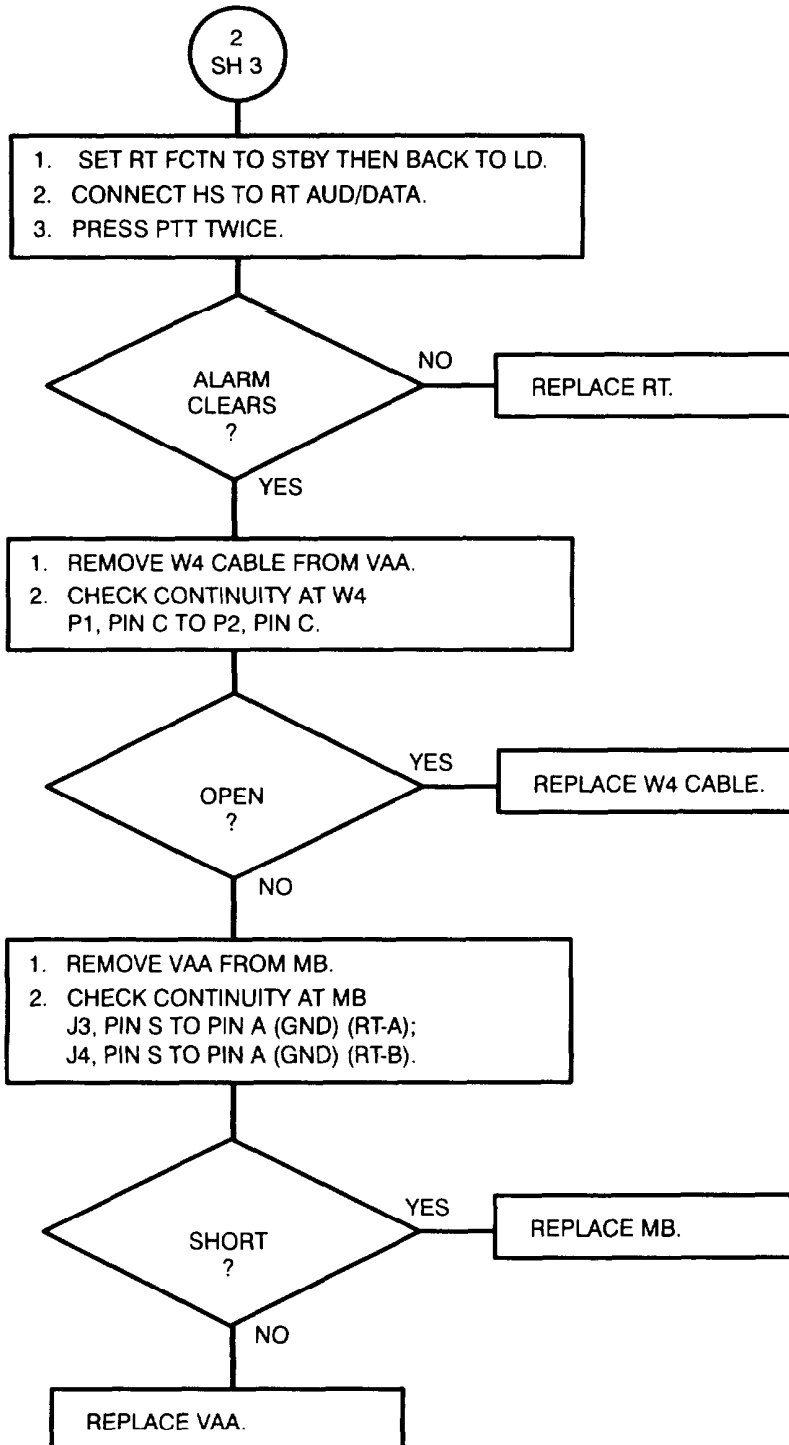

NOTE:

AM-7239C/D/E utilizes W4 only when passing packet data on tactical internet. Disregard W4 checks for normal troubleshooting.

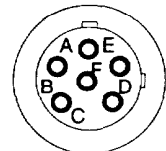

W4 P1/P2

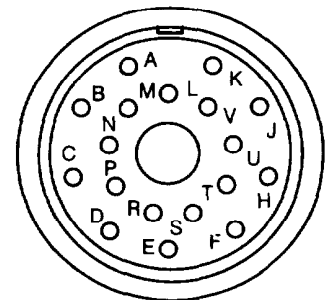

MB J3/J4

3.2. TROUBLESHOOTING FLOWCHARTS. Continued  
Chart 10

COMSEC ALARM NOT HEARD OR WILL NOT CLEAR (EXTERNAL DEVICES PRESENT).  
(Sheet 1 of 5)

ALARM NOT HEARD

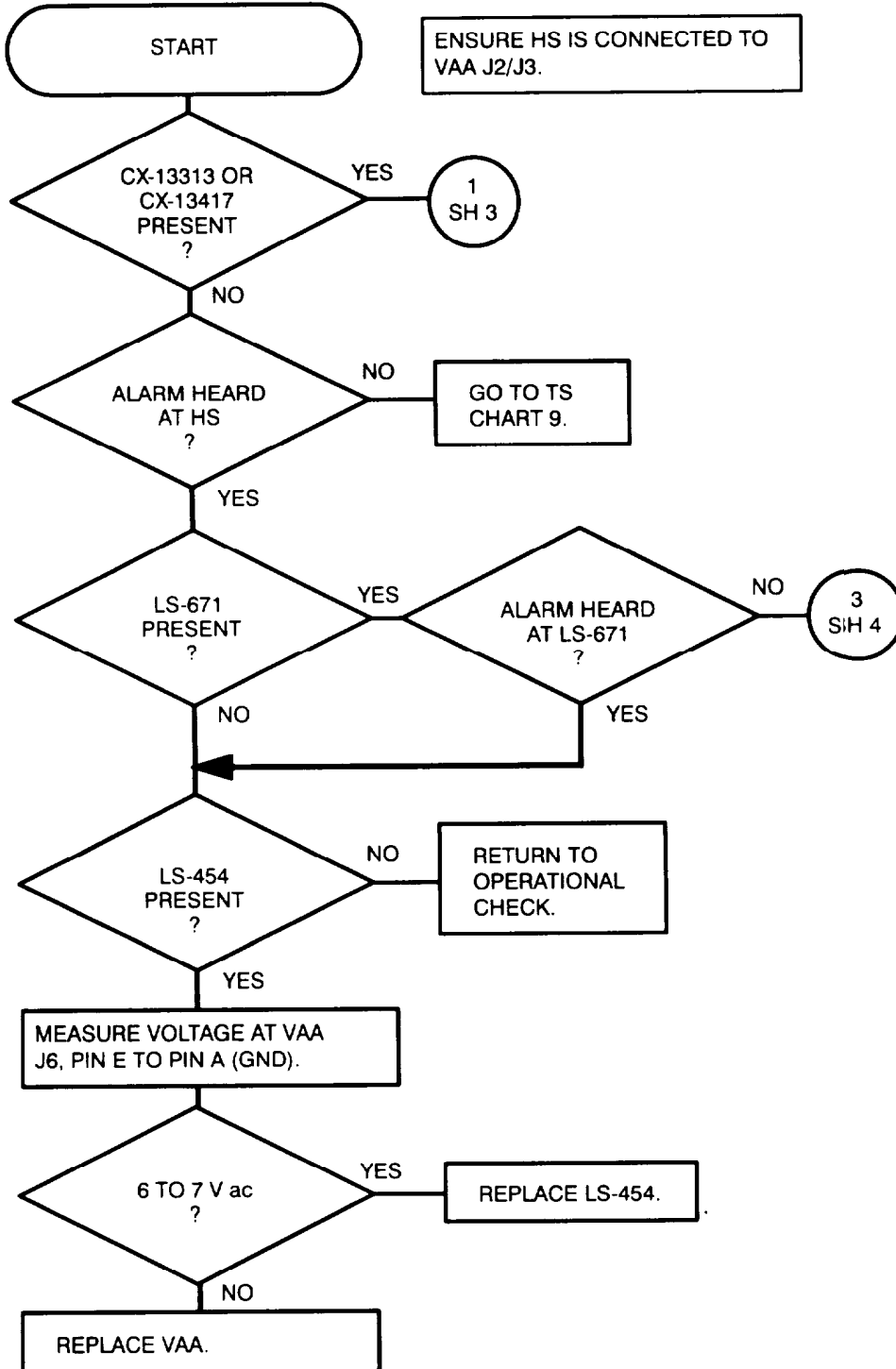

NOTE:

ALARM WILL NOT CLEAR condition go to sheet 2 of 5.

3.2. TROUBLESHOOTING FLOWCHARTS. Continued

Chart 10

COMSEC ALARM NOT HEARD OR WILL NOT CLEAR (EXTERNAL DEVICES PRESENT).

(Sheet 2 of 5)

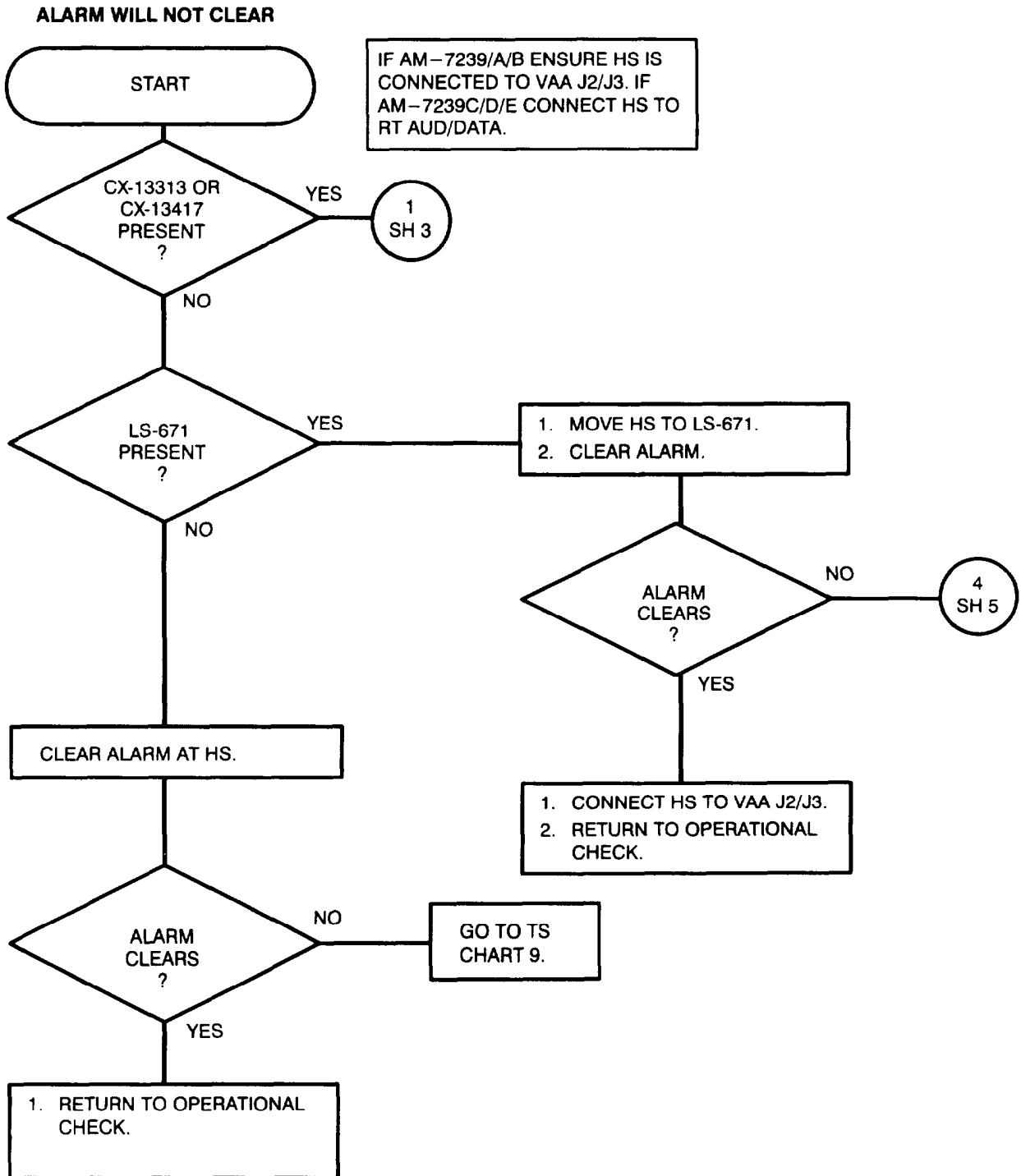

3.2. TROUBLESHOOTING FLOWCHARTS. Continued

Chart 10

COMSEC ALARM NOT HEARD OR WILL NOT CLEAR (EXTERNAL DEVICES PRESENT).  
(Sheet 3 of 5)

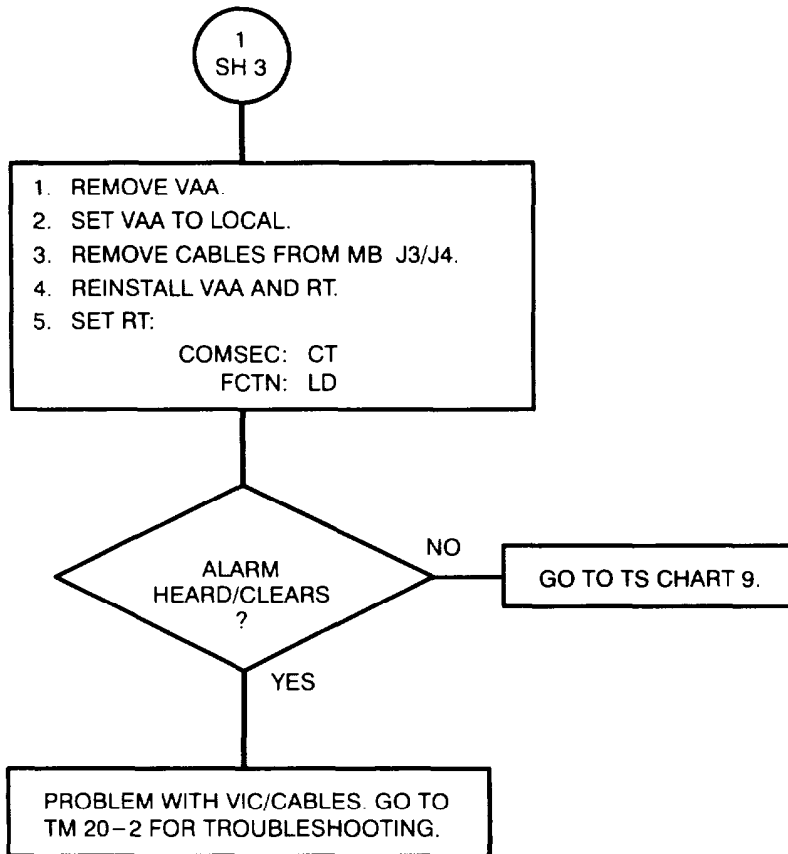

3.2. TROUBLESHOOTING FLOWCHARTS. Continued

Chart 10

COMSEC ALARM NOT HEARD OR WILL NOT CLEAR (EXTERNAL DEVICES PRESENT).

(Sheet 4 of 5)

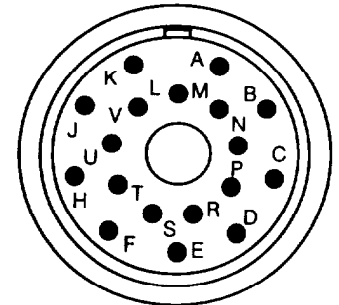
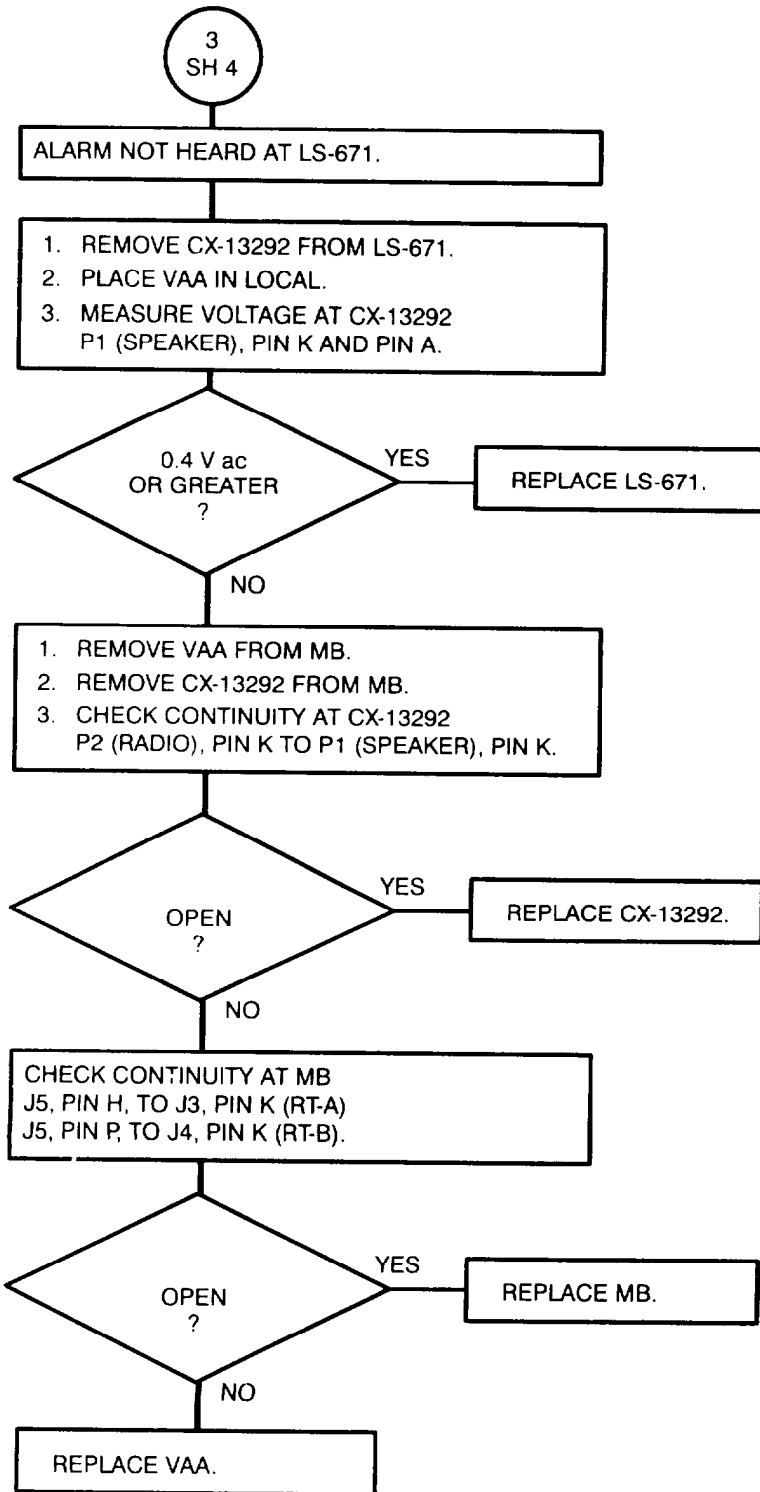

CX-13292 P1/P2

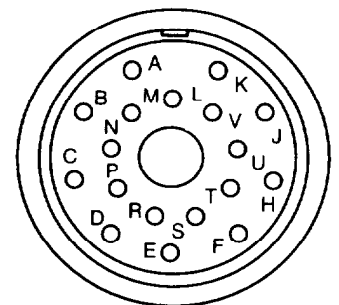

MB J3/J4

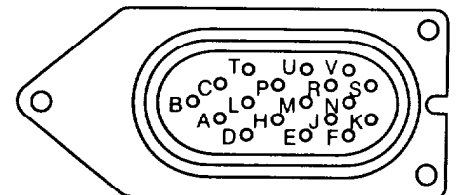

MB J5

3.2. TROUBLESHOOTING FLOWCHARTS. Continued

Chart 10

COMSEC ALARM NOT HEARD OR WILL NOT CLEAR (EXTERNAL DEVICES PRESENT).  
(Sheet 5 of 5)

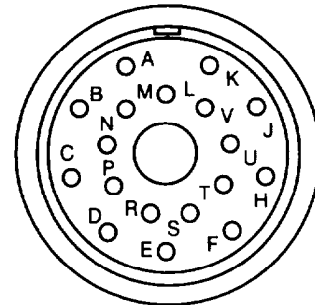
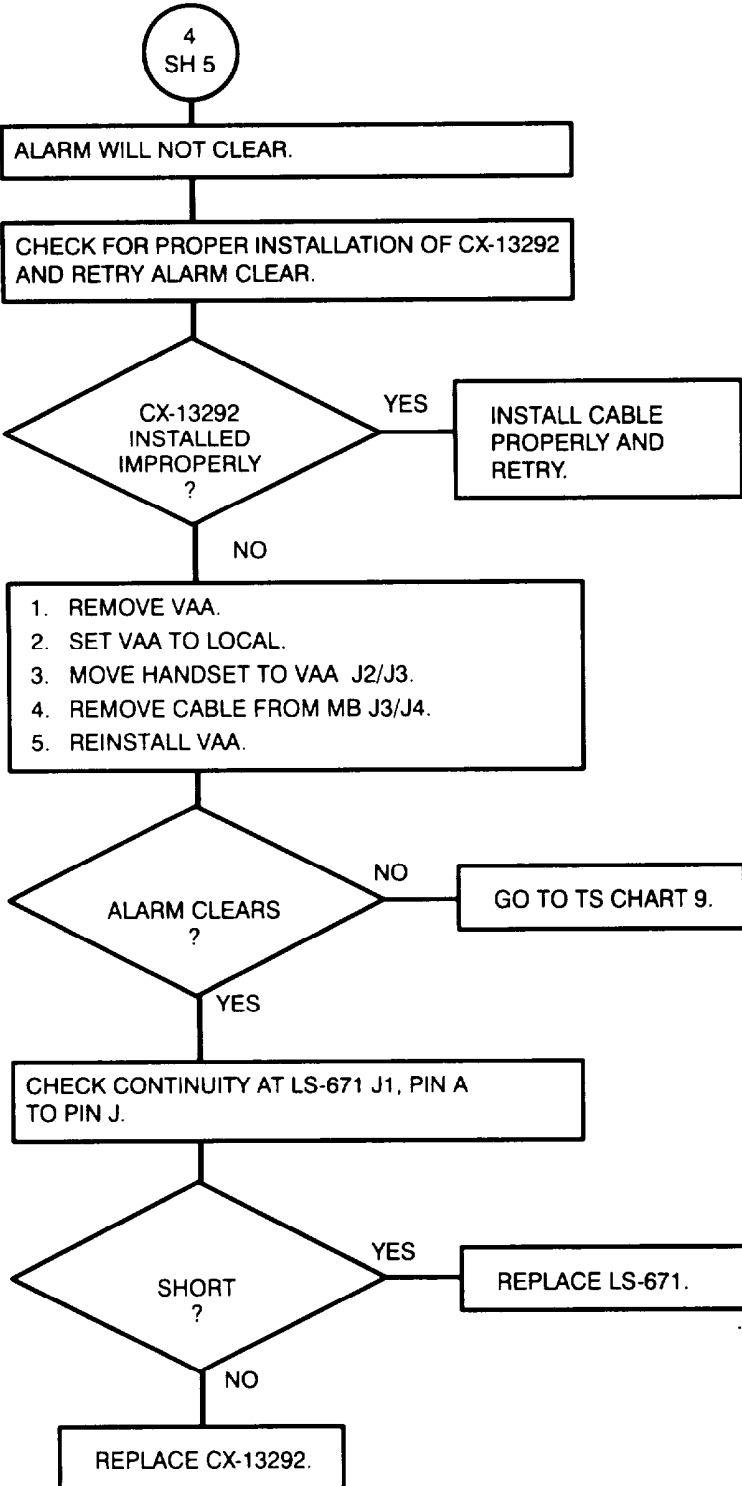

LS-671 J1



3.2. TROUBLESHOOTING FLOWCHARTS. Continued

Chart 11

VARIABLE (COMSEC OR FH DATA) WILL NOT LOAD.  
(Sheet 1 of 2)

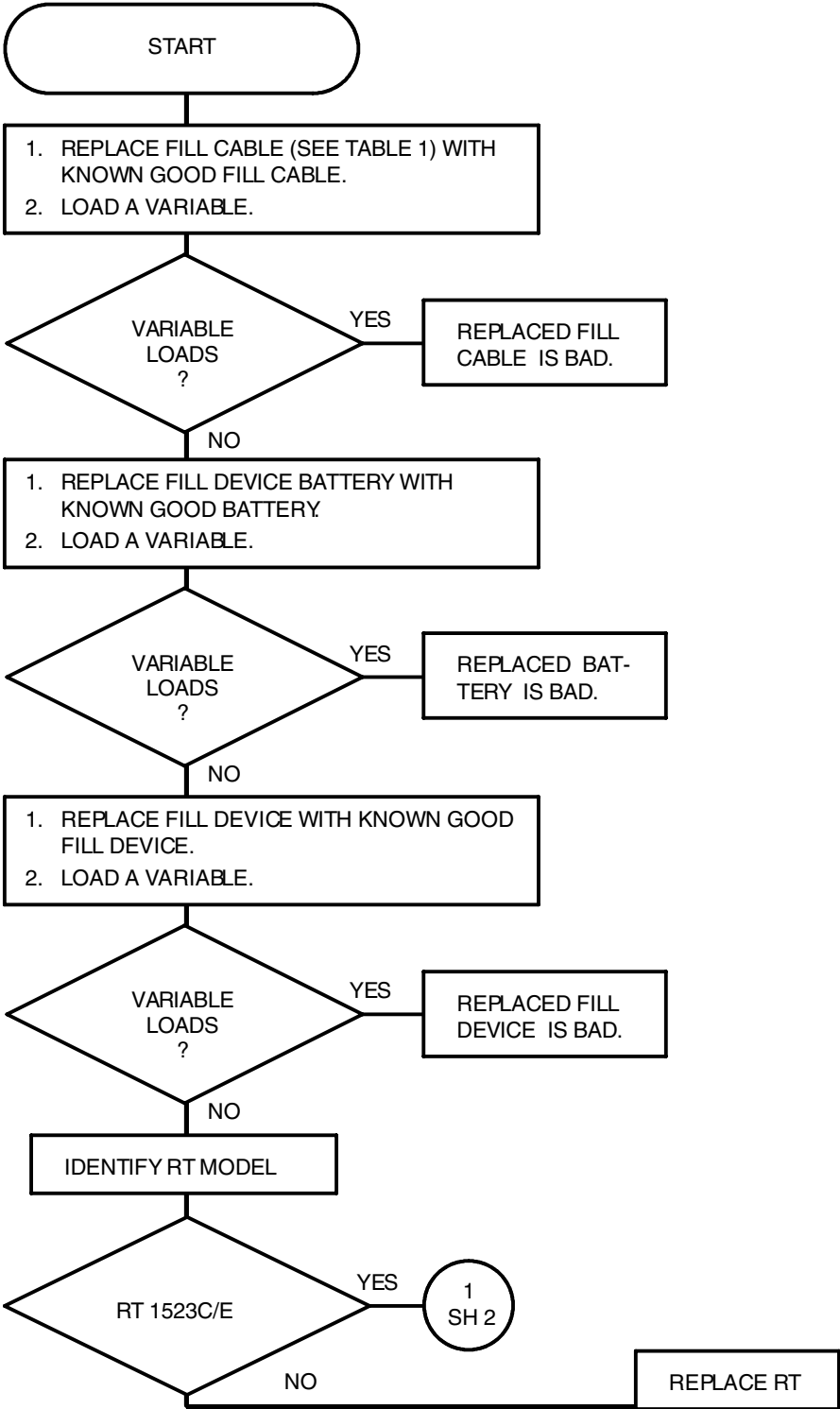

3.2. TROUBLESHOOTING FLOWCHARTS. Continued

Chart 11

VARIABLE (COMSEC OR FH DATA) WILL NOT LOAD.  
(Sheet 2 of 2)

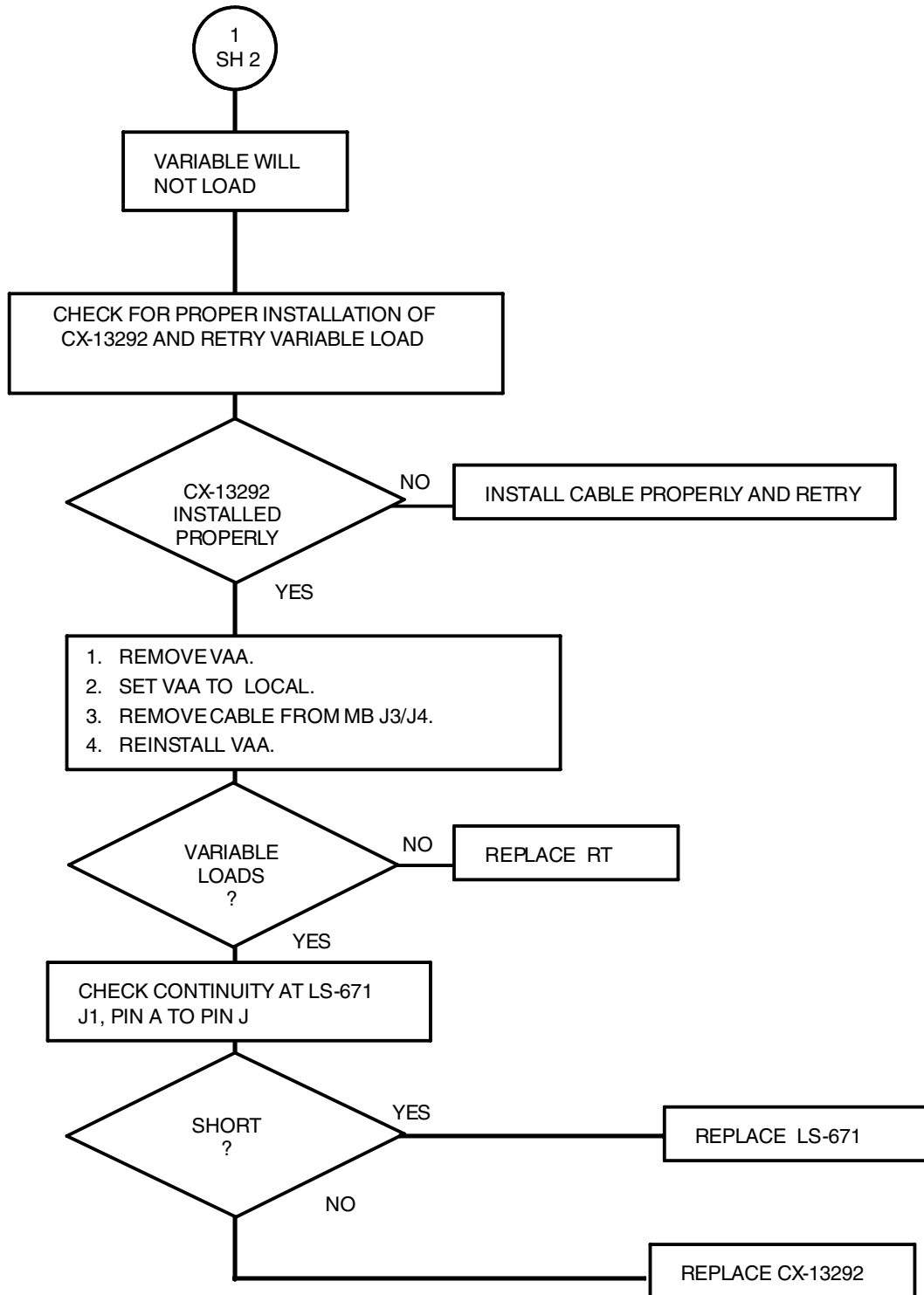

3.2. TROUBLESHOOTING FLOWCHARTS. Continued

Chart 12

FAILED FORWARD AND REVERSE POWER CHECK.  
(Sheet 1 of 3)

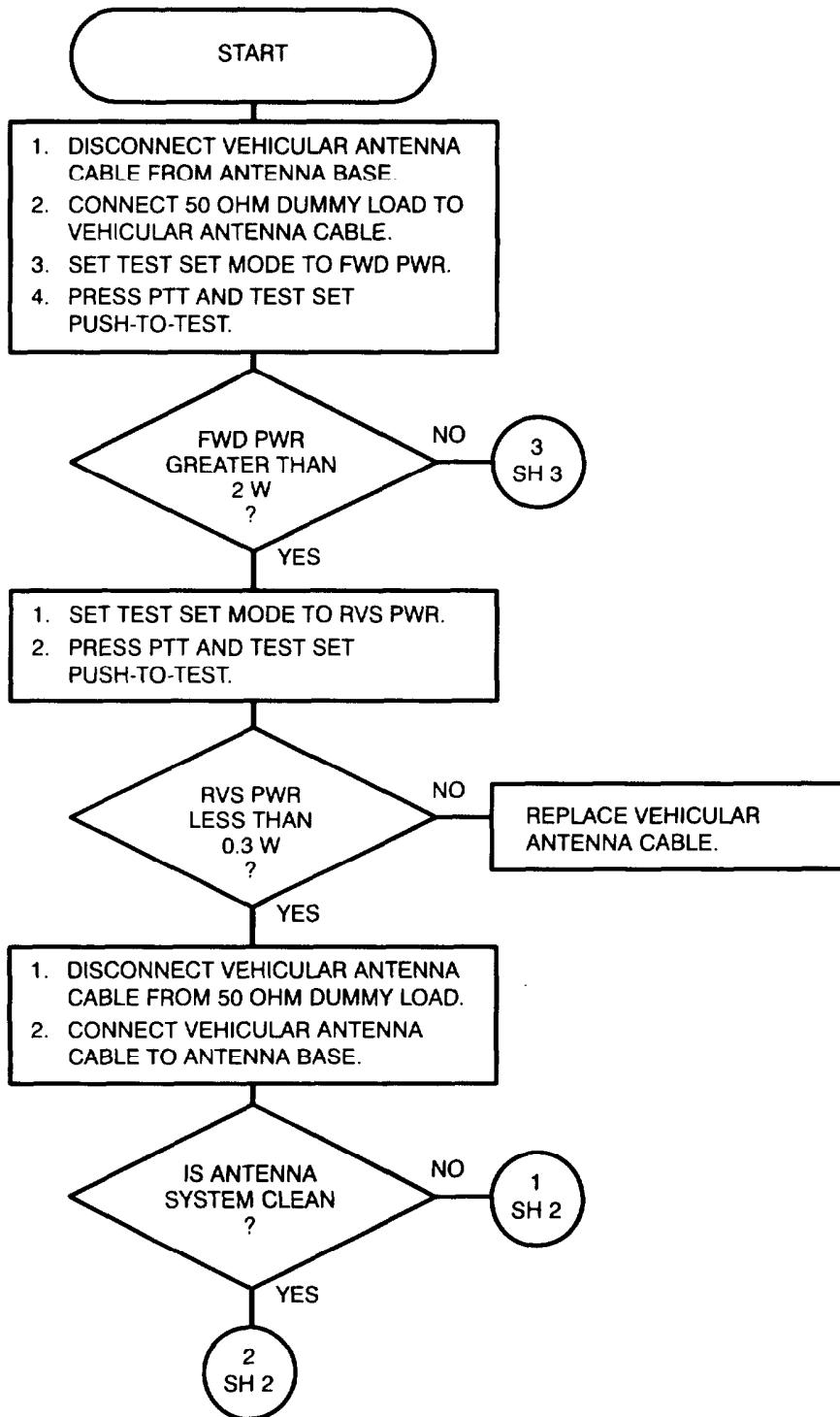

3.2. TROUBLESHOOTING FLOWCHARTS. Continued

Chart 12

**FAILED FORWARD AND REVERSE POWER CHECK.**  
(Sheet 2 of 3)

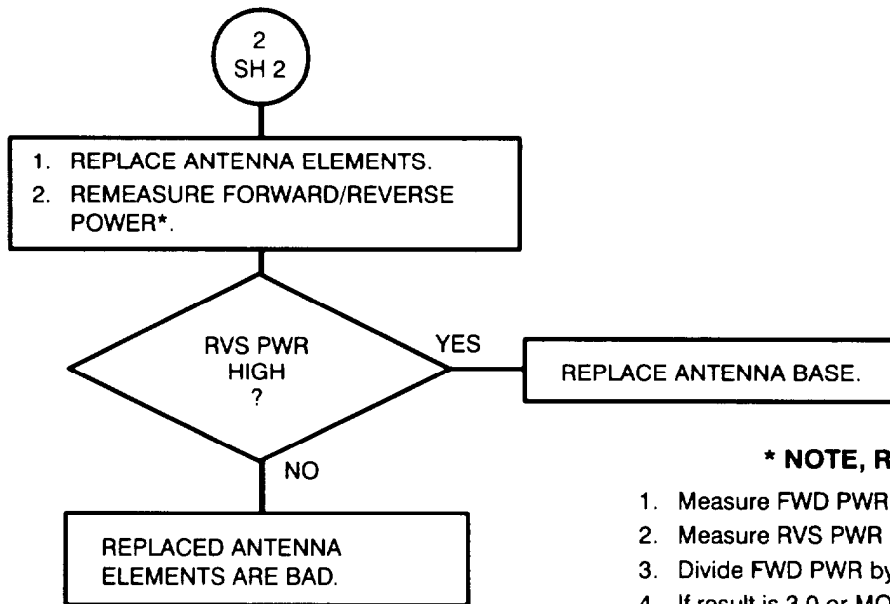
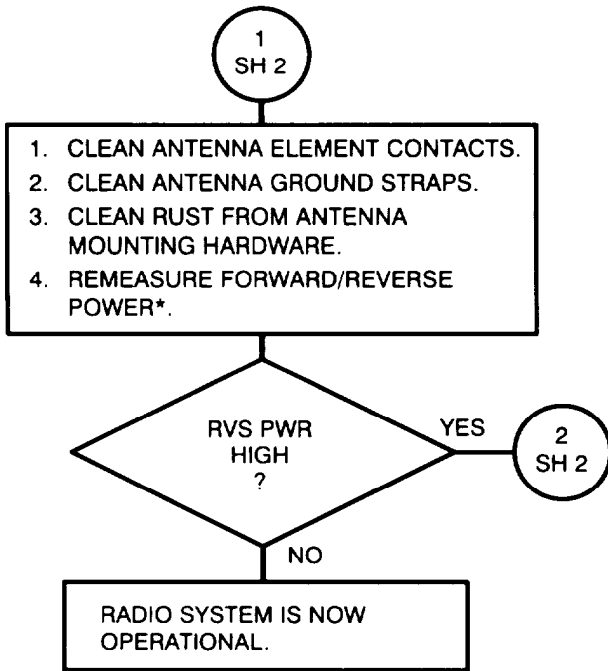

**\* NOTE, RVS PWR QUICK CHECK:**

1. Measure FWD PWR (e.g., 4.6 W).
2. Measure RVS PWR (e.g., 1.2 W).
3. Divide FWD PWR by RVS PWR (e.g., 4.6/1.2).
4. If result is 3.0 or MORE, RVS PWR is normal.
5. If result is LESS THAN 3.0, RVS PWR is high, troubleshoot.
6. If radio is used for data transmission, use 4.0 RVS PWR value.

3.2. TROUBLESHOOTING FLOWCHARTS. Continued

Chart 12

FAILED FORWARD AND REVERSE POWER CHECK.

(Sheet 3 of 3)

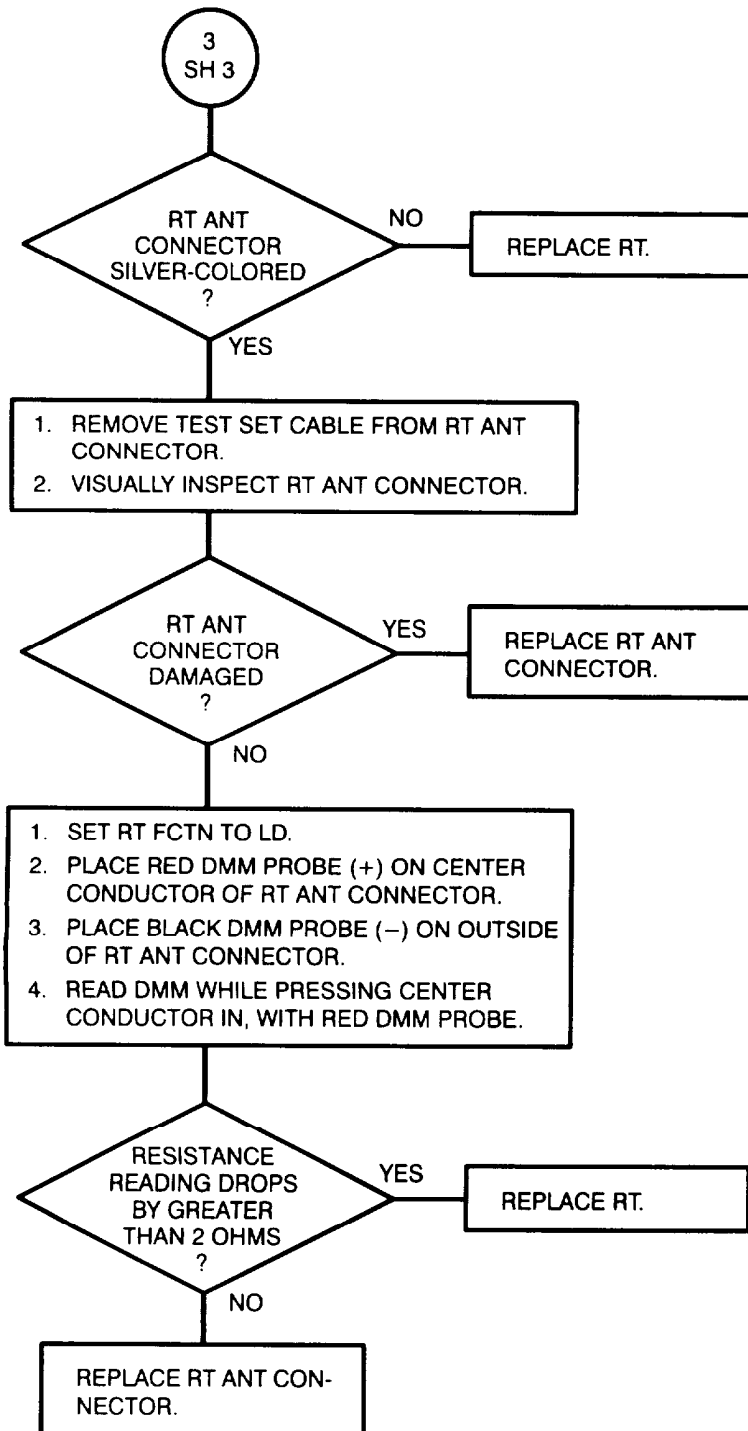

3.2. TROUBLESHOOTING FLOWCHARTS. Continued

Chart 13

NO SIDETONE (FORWARD/REVERSE POWER CORRECT RF PWR IN HI).  
(Sheet 1 of 1)

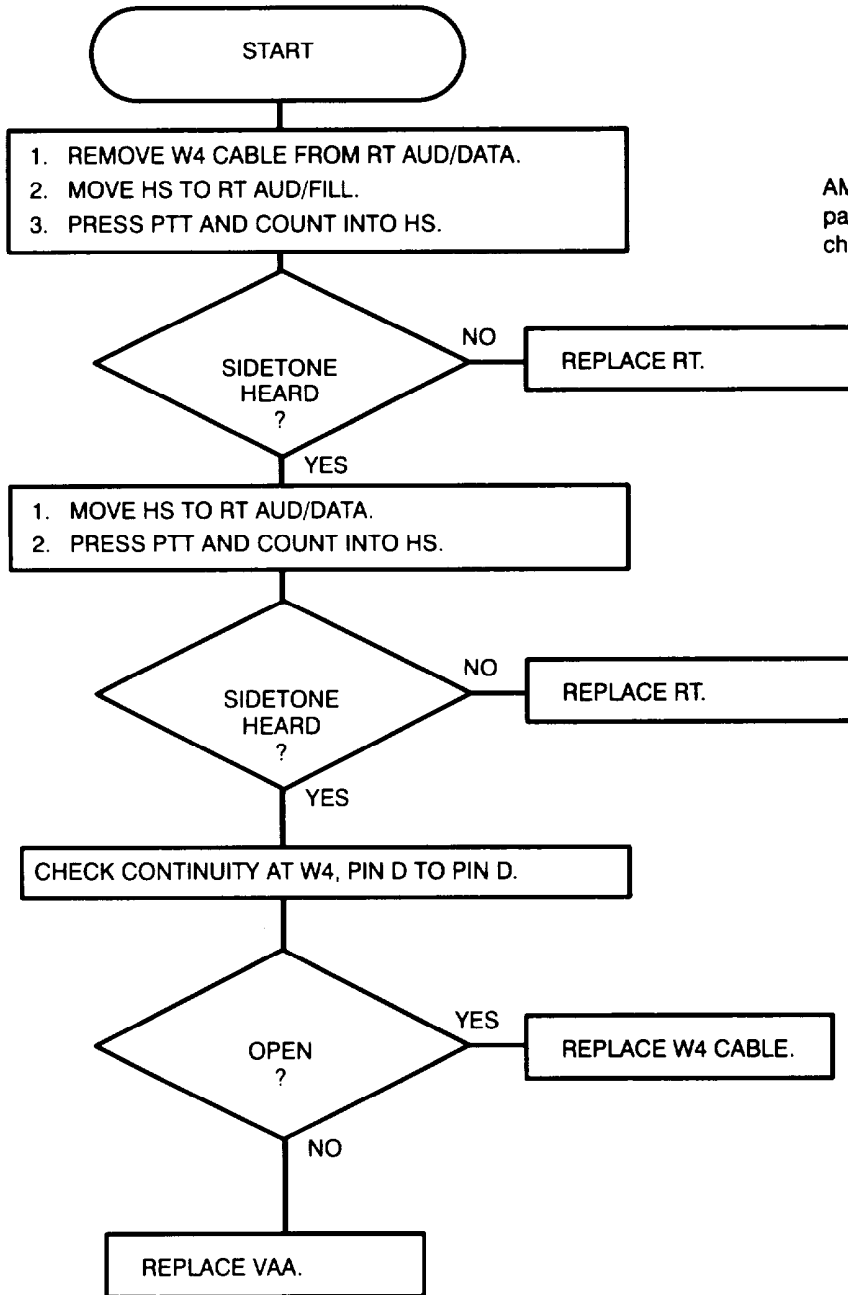

**NOTE:**

AM-7239C/D/E utilizes W4 only when passing packet data on tactical internet. Disregard W4 checks for normal troubleshooting.

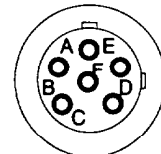

W4 P1, P2

3.2. TROUBLESHOOTING FLOWCHARTS. Continued

Chart 14

FORWARD POWER INCORRECT THRU PA IN RF PWR HI.  
(Sheet 1 of 2)

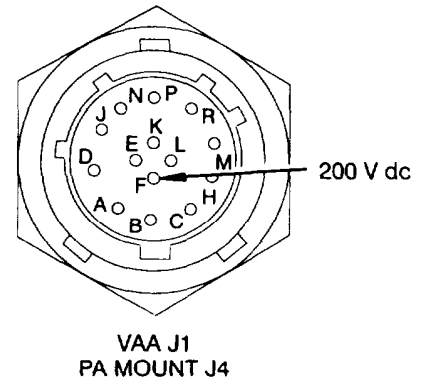
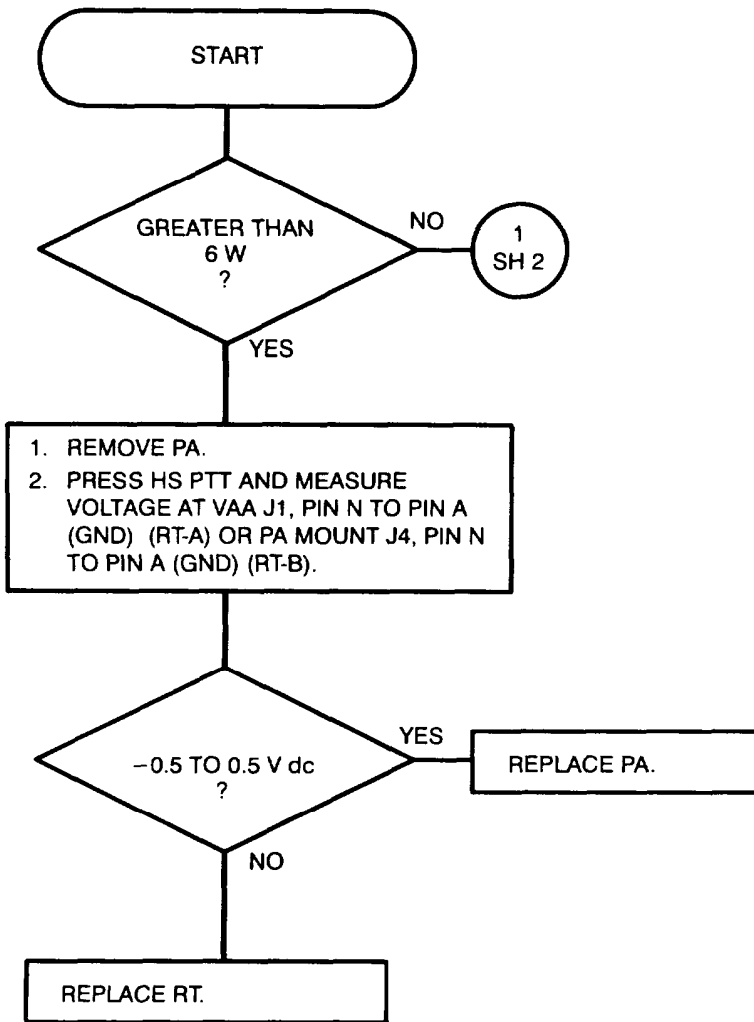

**WARNING**

Connector J1 of the VAA and J4 of the PA mount have 200 V dc on pin F. Use extreme care in measuring voltages on connectors VAA J1 or PA mount J4.

3.2. TROUBLESHOOTING FLOWCHARTS. Continued

Chart 14

FORWARD POWER INCORRECT THRU PA IN RF PWR HI.

(Sheet 2 of 2)

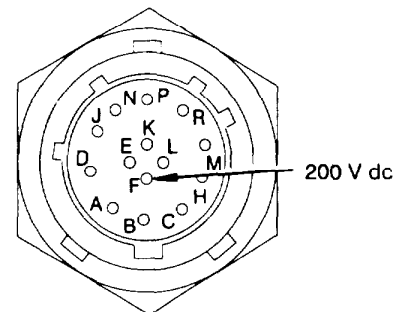
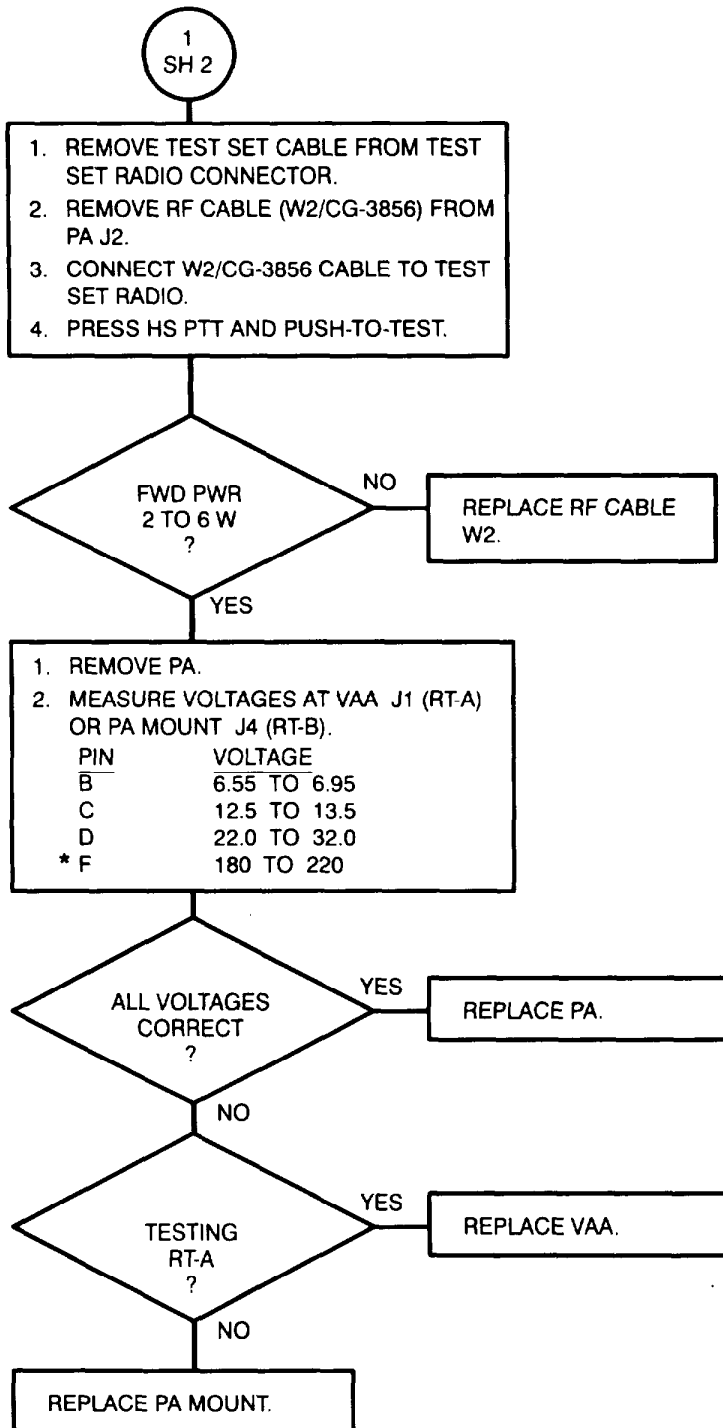

VAA J1  
PA MOUNT J4

**\* WARNING**  
Connector J1 of the VAA and J4 of the PA mount have 200 V dc on pin F. Use extreme care in measuring voltages on connectors VAA J1 or PA mount J4.



3.2. TROUBLESHOOTING FLOWCHARTS. Continued

Chart 15

RT-A: LESS THAN 30 W FORWARD POWER OUT OF PA FROM 30 TO 43 MHZ.

(Sheet 1 of 2)

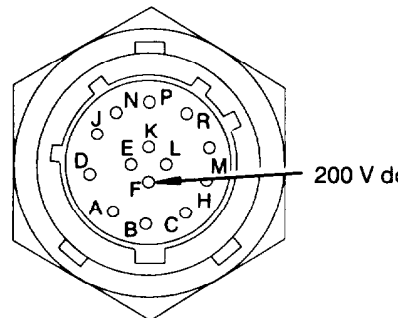
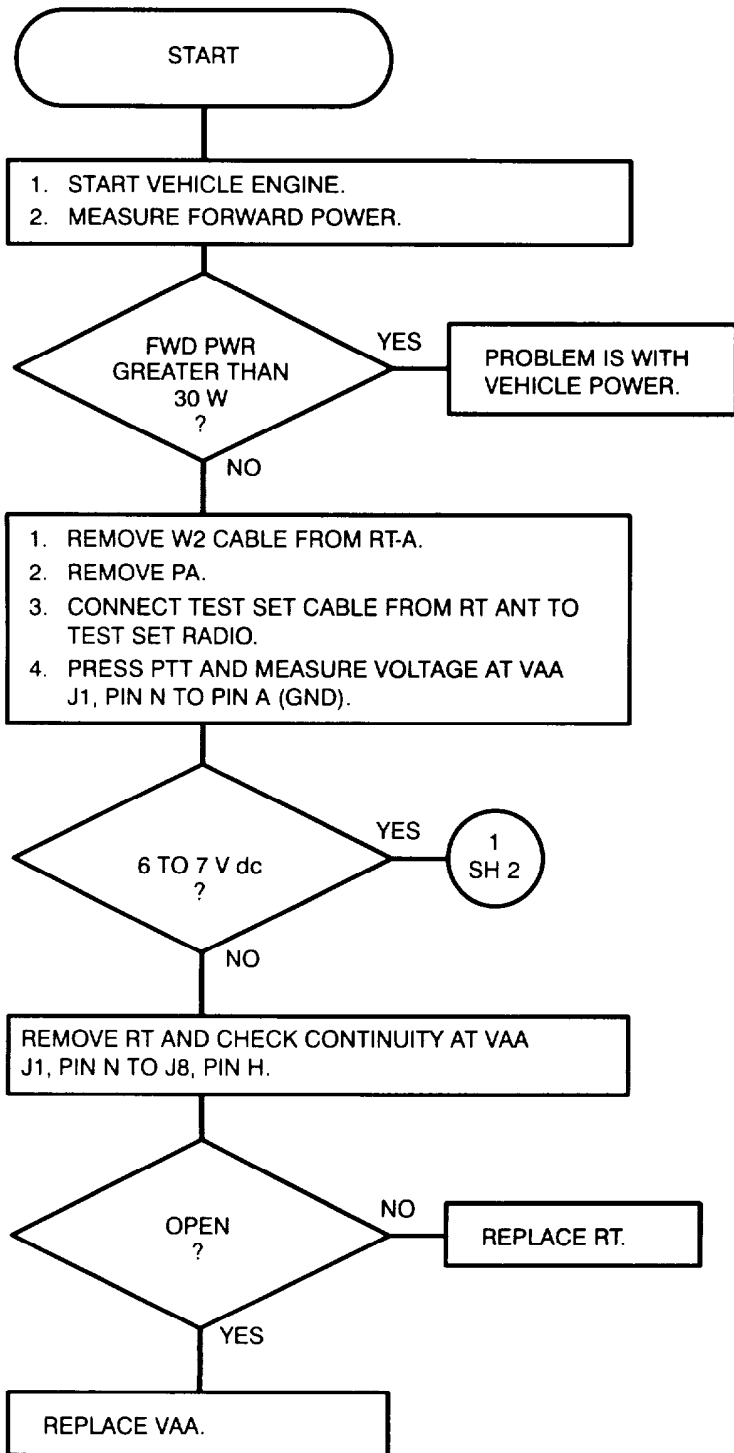

VAA J1

**WARNING**  
Connector J1 of the VAA has 200 V dc on pin F. Use extreme care in measuring voltages on connector J1.

3.2. TROUBLESHOOTING FLOWCHARTS. Continued

Chart 15

RT-A: LESS THAN 30 W FORWARD POWER OUT OF PA FROM 30 TO 43 MHZ.  
(Sheet 2 of 2)

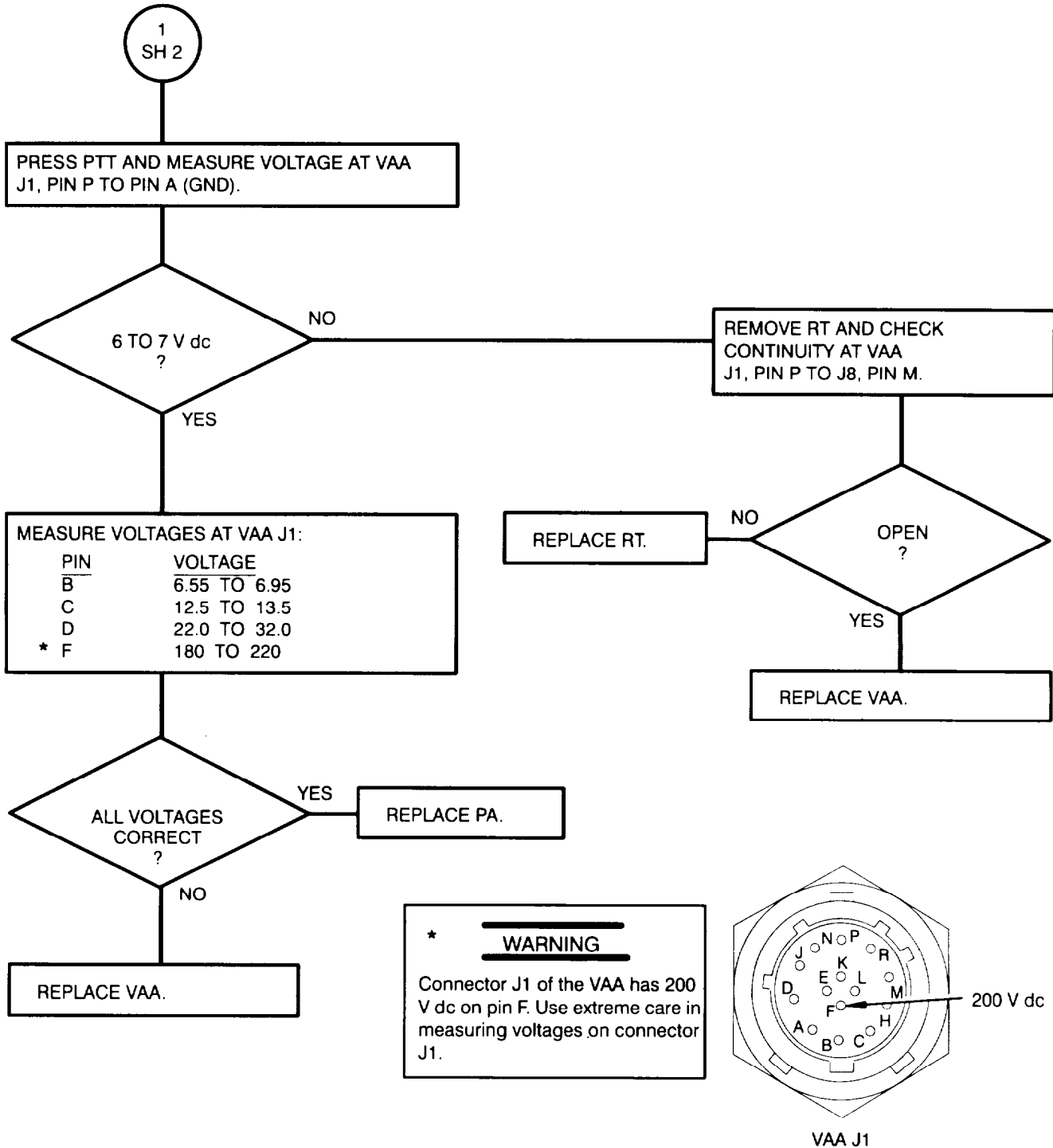

3.2. TROUBLESHOOTING FLOWCHARTS. Continued

Chart 16

RT-B: LESS THAN 30 W FORWARD POWER OUT OF PA FROM 30 TO 43 MHZ.

(Sheet 1 of 3)

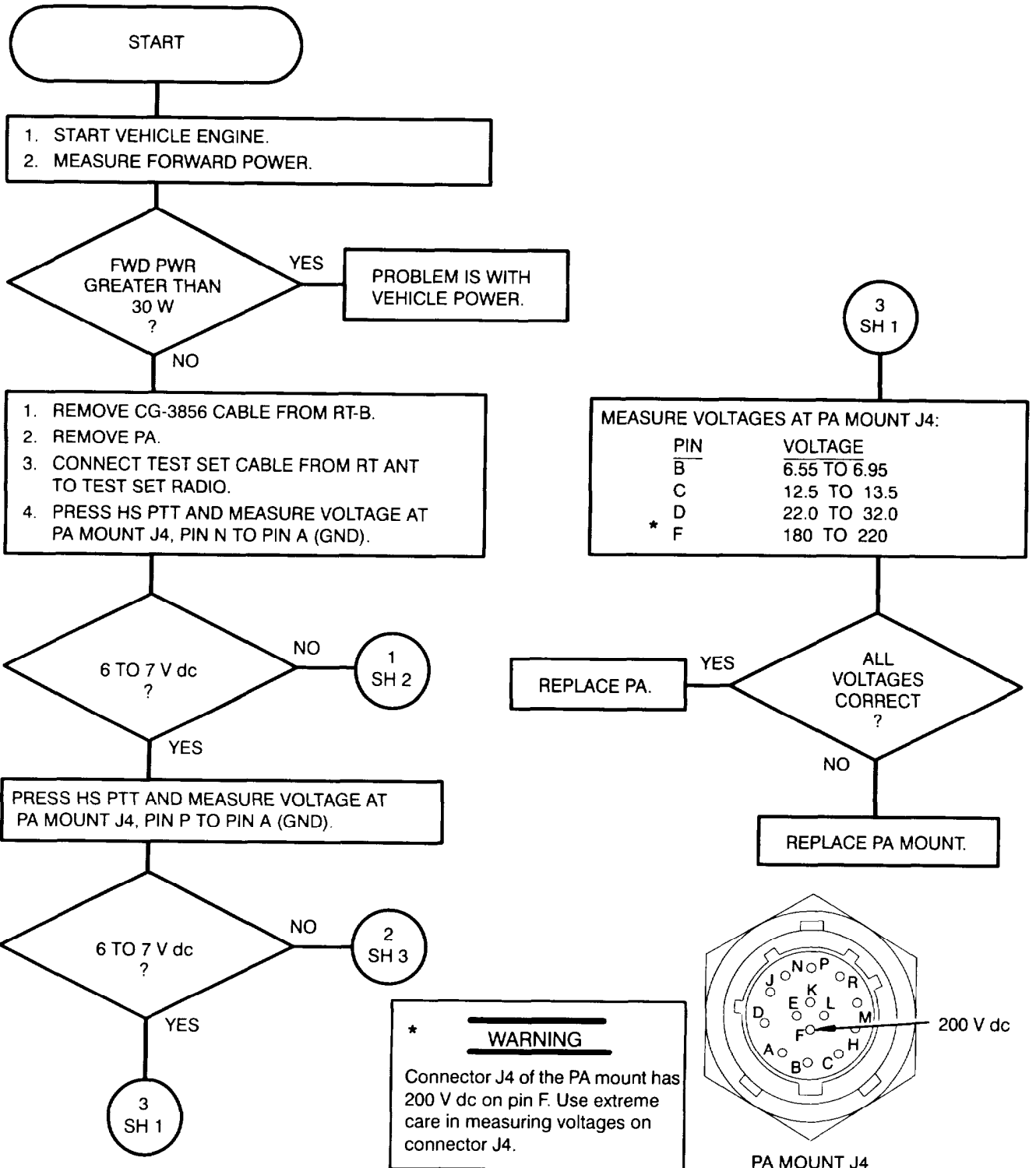

3.2. TROUBLESHOOTING FLOWCHARTS. Continued

Chart 16

RT-B: LESS THAN 30 W FORWARD POWER OUT OF PA FROM 30 TO 43 MHZ.  
(Sheet 2 of 3)

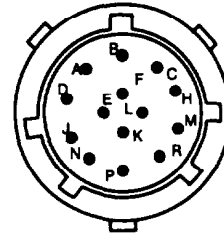
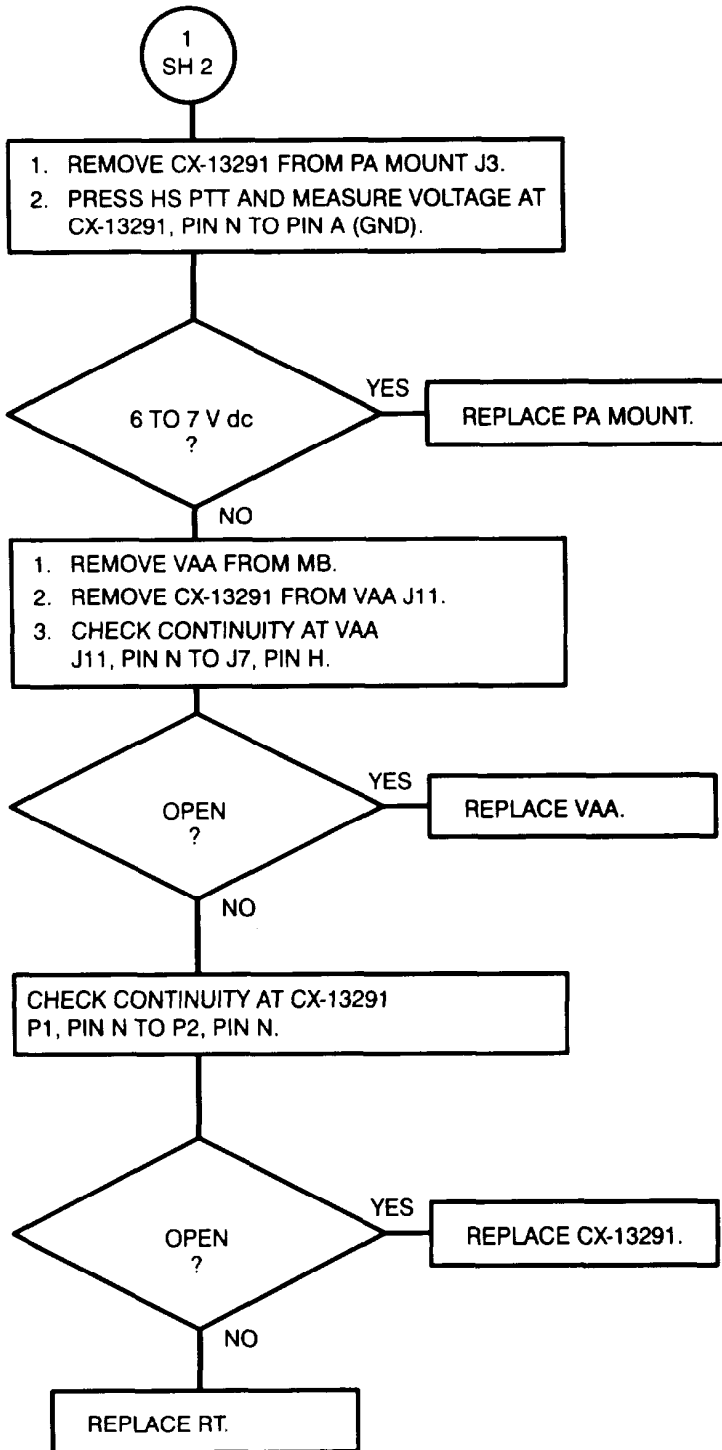

CX-13291 P1/P2

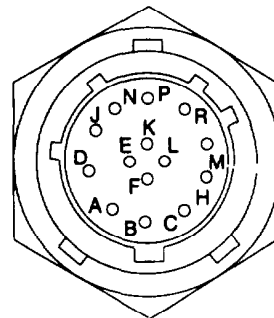

VAA J11

3.2. TROUBLESHOOTING FLOWCHARTS. Continued

Chart 16

RT-B: LESS THAN 30 W FORWARD POWER OUT OF PA FROM 30 TO 43 MHZ.

(Sheet 3 of 3)

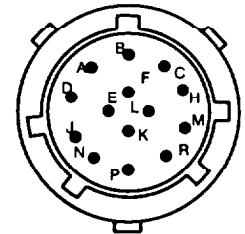
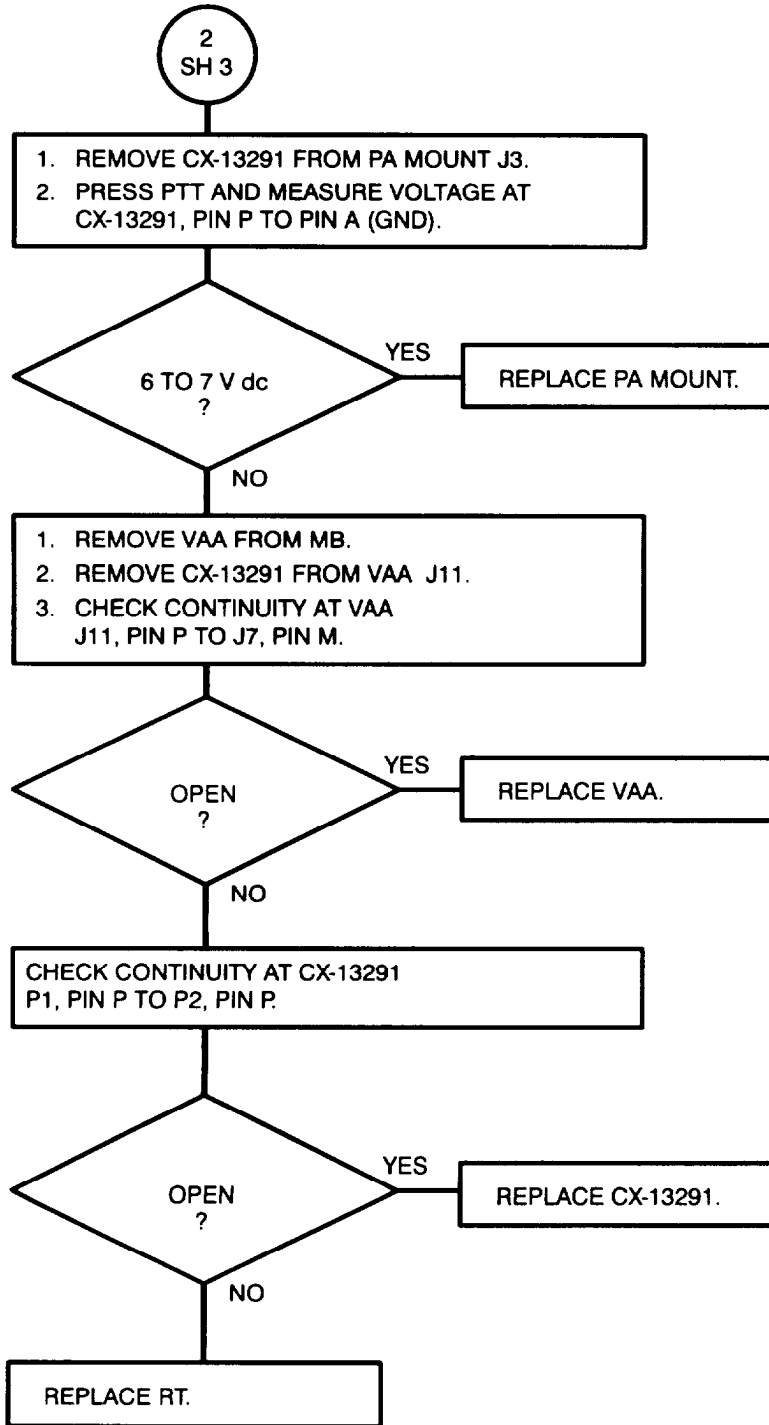

CX-13291 P1/P2

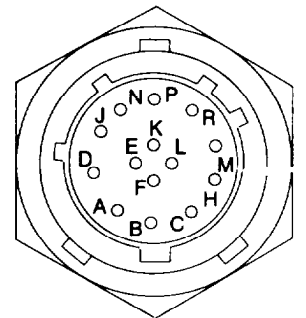

VAA J11

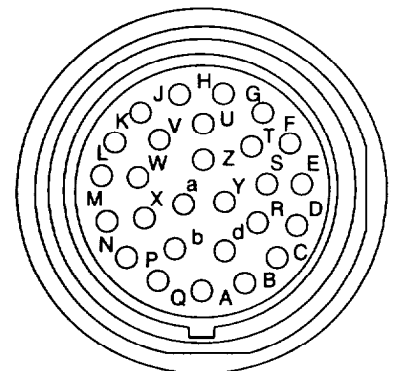

VAA J7

3.2. TROUBLESHOOTING FLOWCHARTS. Continued

Chart 17

RT-A: LESS THAN 30 W FORWARD POWER OUT OF PA  
FROM EITHER 43 TO 61.4 MHZ OR 61.4 TO 88 MHZ.

(Sheet 1 of 1)

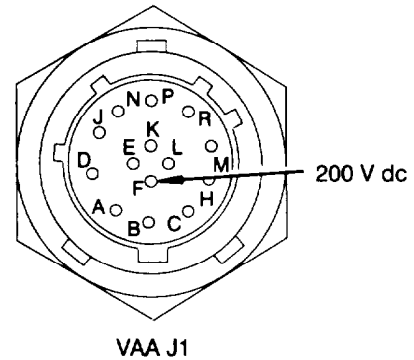
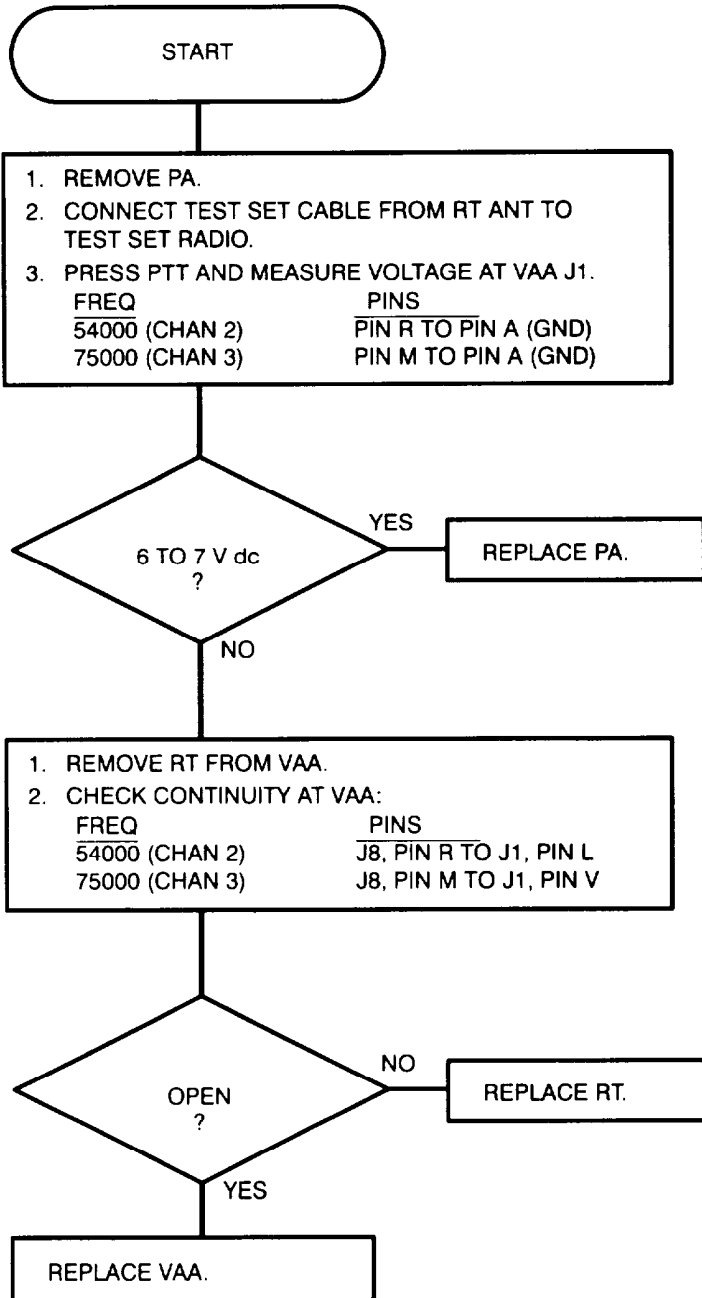

**WARNING**

Connector J1 of the VAA has 200 V dc on pin F. Use extreme care in measuring voltages on connector J1.

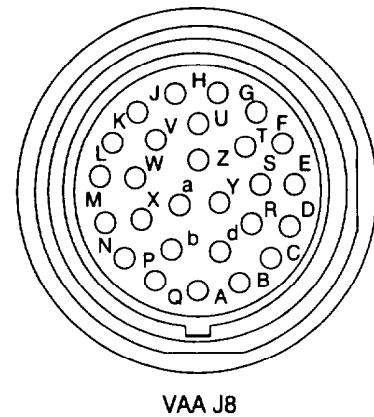

3.2. TROUBLESHOOTING FLOWCHARTS. Continued

Chart 18

RT-B: LESS THAN 30 W FORWARD POWER OUT OF PA  
FROM EITHER 43 TO 61.4 MHZ OR 61.4 TO 88 MHZ.

(Sheet 1 of 2)

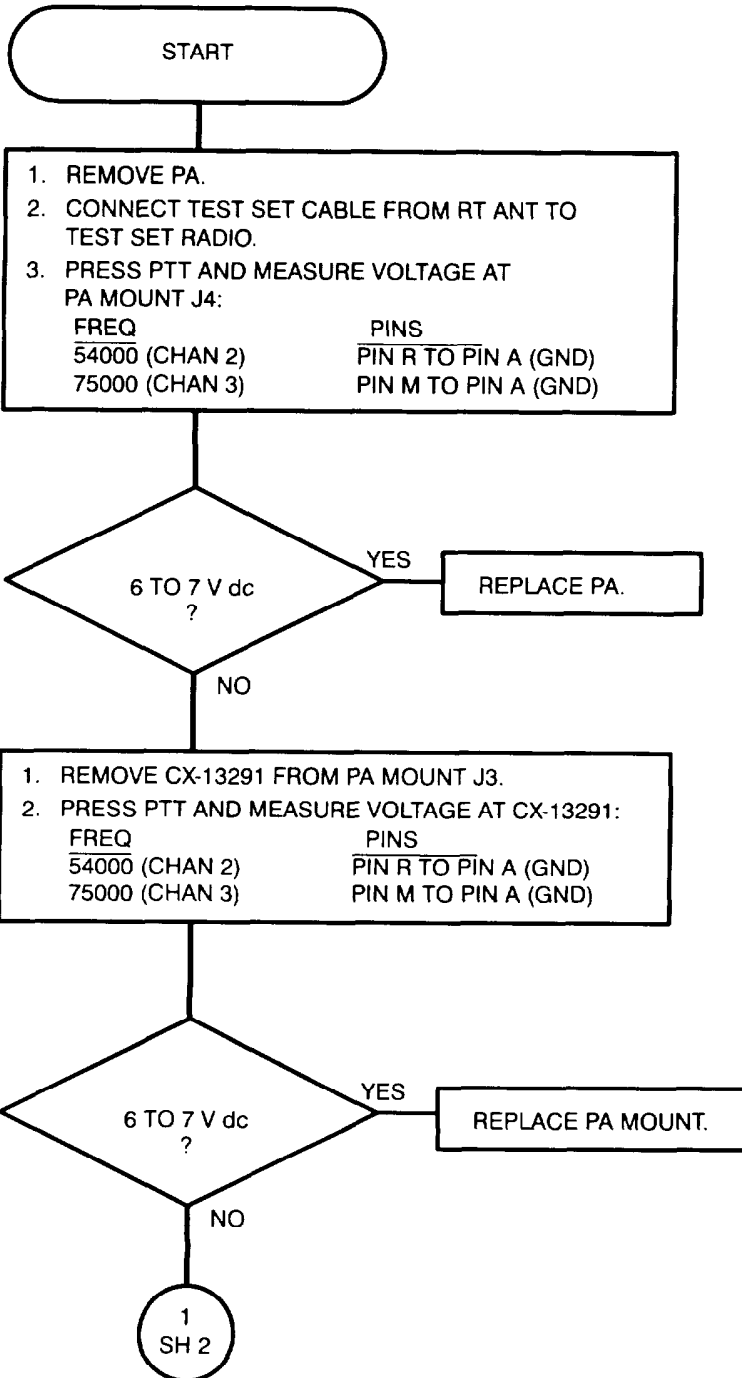

**WARNING**  
Connector J4 of the PA mount has 200 V dc on pin F. Use extreme care in measuring voltages on connector J4.

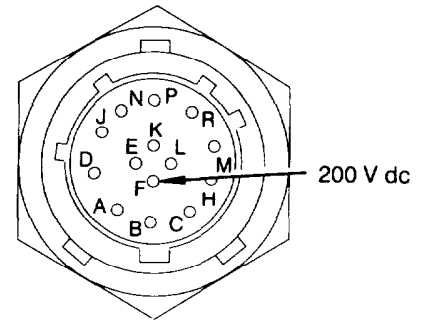

PA MOUNT J4

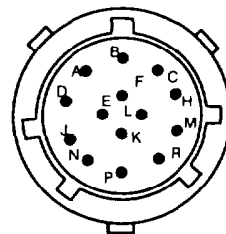

CX-13291 P1/P2

3.2. TROUBLESHOOTING FLOWCHARTS. Continued

Chart 18

RT-B: LESS THAN 30 W FORWARD POWER OUT OF PA  
FROM EITHER 43 TO 61.4 MHZ OR 61.4 TO 88 MHZ.

(Sheet 2 of 2)

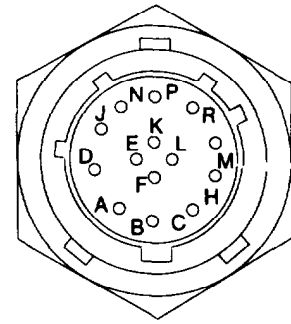
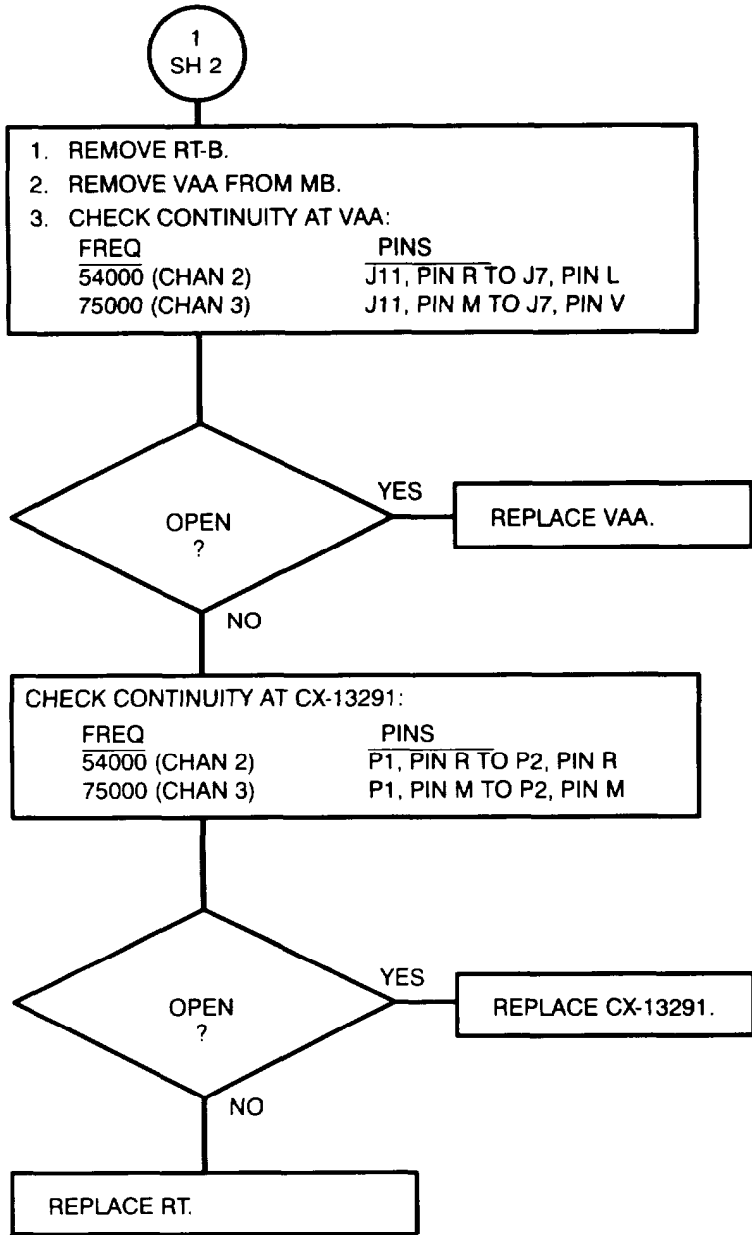

VAA J11

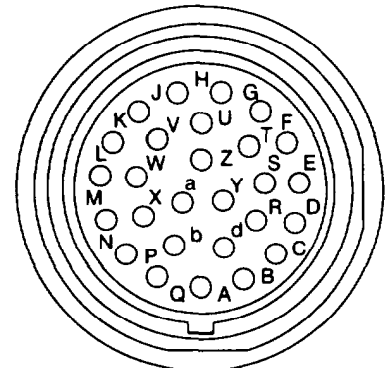

VAA J7

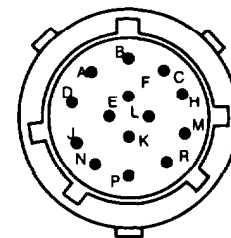

CX-13291 P1/P2



3.2. TROUBLESHOOTING FLOWCHARTS. Continued

Chart 19

RT SIG DISPLAY INCORRECT WITH RT RF PWR SWITCH SET TO 'PA'.

(Sheet 1 of 2)

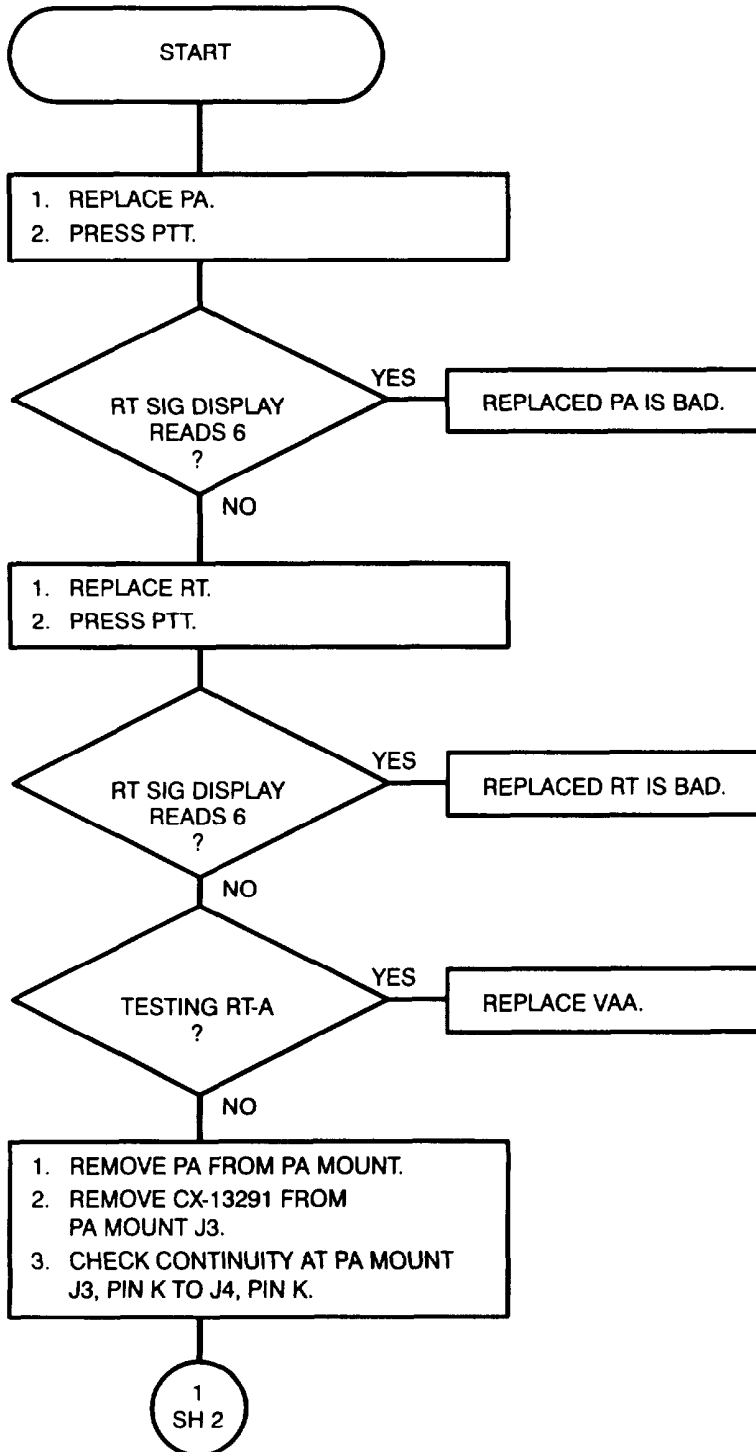

**WARNING**

Connector J4 of the PA mount has 200 V dc on pin F. Use extreme care in measuring voltages on connector J4.

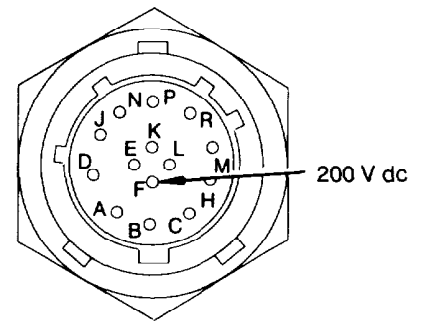

PA MOUNT J4

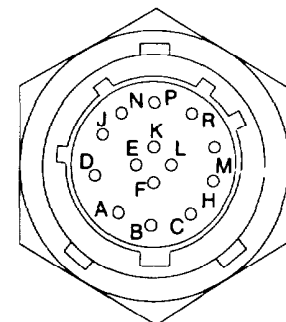

PA MOUNT J3

3.2. TROUBLESHOOTING FLOWCHARTS. Continued

Chart 19

RT SIG DISPLAY INCORRECT WITH RT RF PWR SWITCH SET TO 'PA'.

(Sheet 2 of 2)

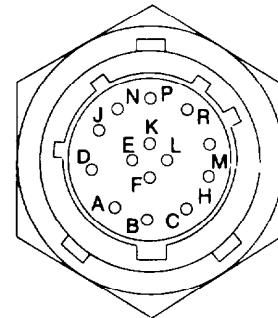
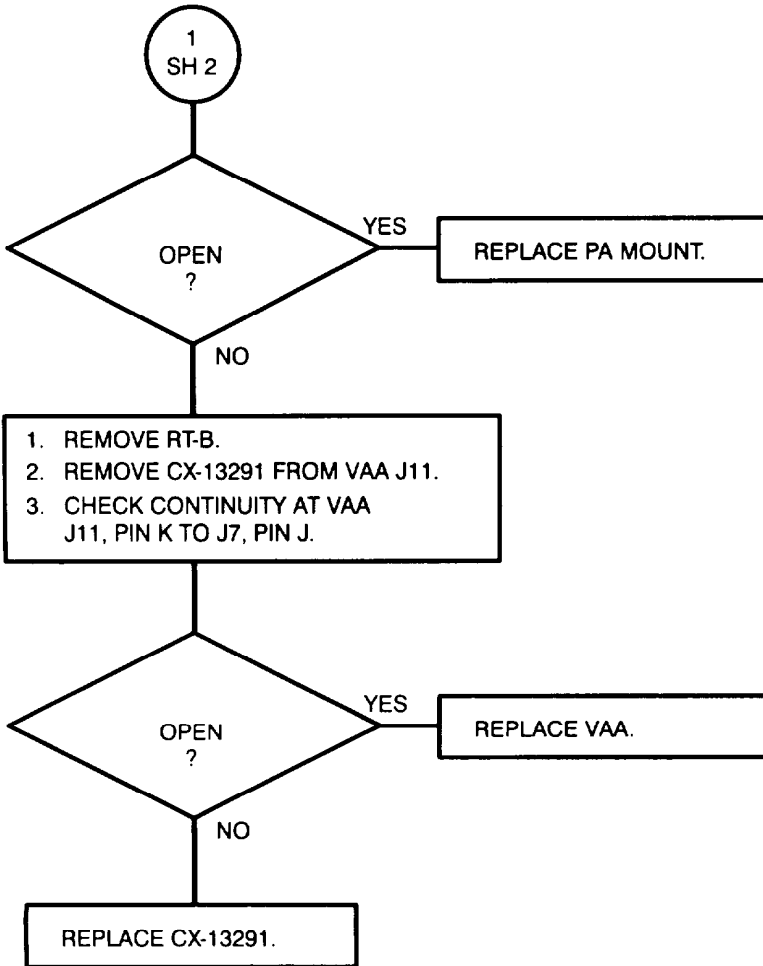

VAA J11

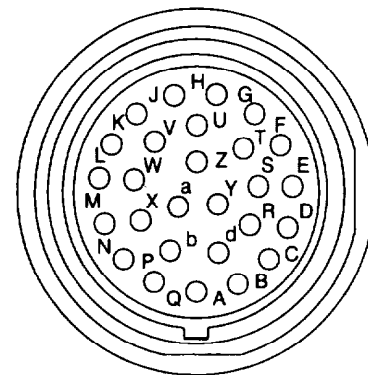

VAA J7

3.2. TROUBLESHOOTING FLOWCHARTS. Continued

Chart 20

RT SIG DISPLAY DOES NOT LIGHT WHEN LS-671 PTT IS PRESSED.

(Sheet 1 of 3)

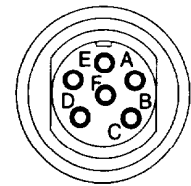
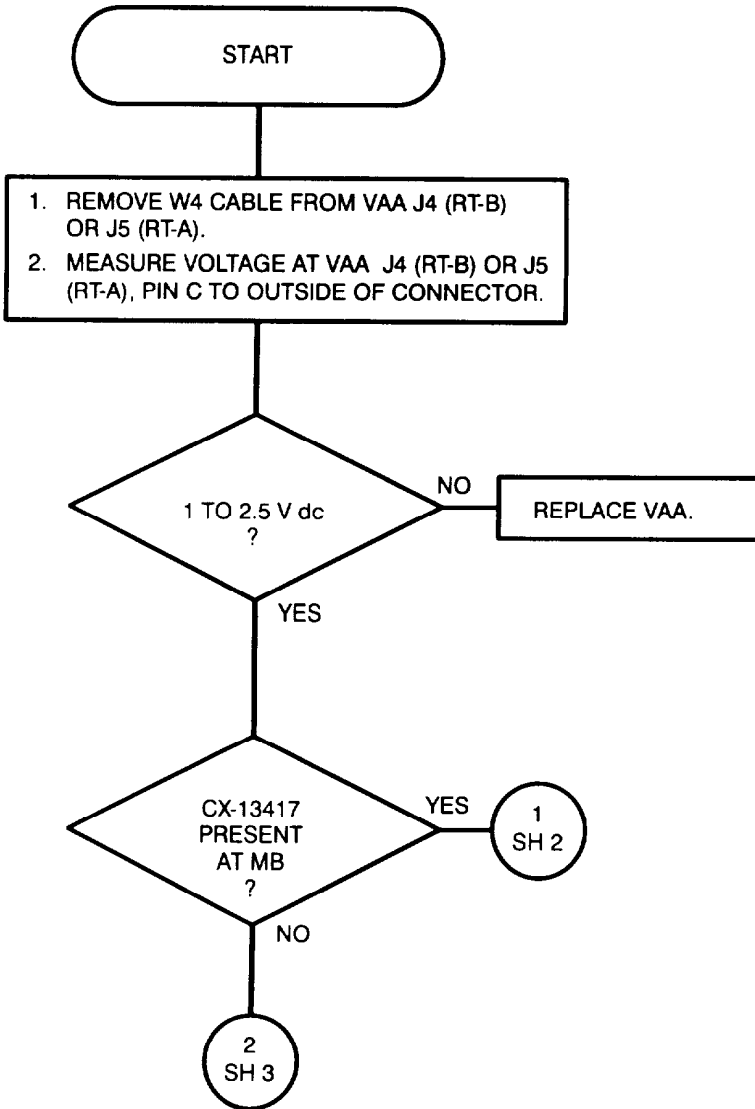

VAA J4/J5

3.2. TROUBLESHOOTING FLOWCHARTS. Continued

Chart 20

RT SIG DISPLAY DOES NOT LIGHT WHEN LS-671 PTT IS PRESSED.

(Sheet 2 of 3)

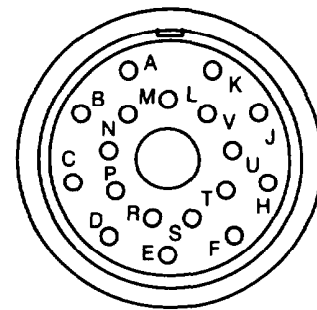
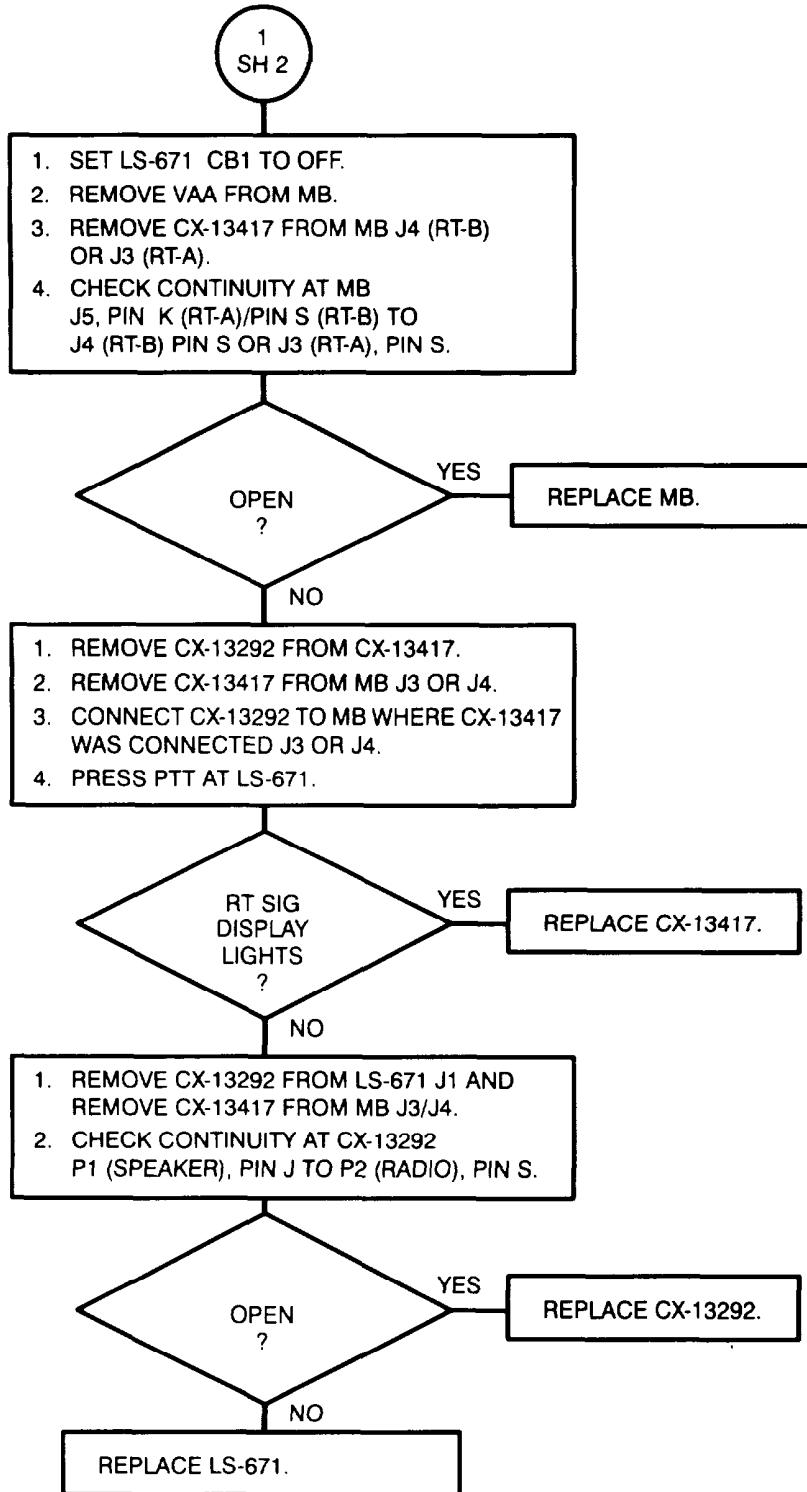

MB J3/J4

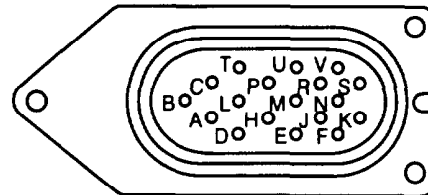

MB J5

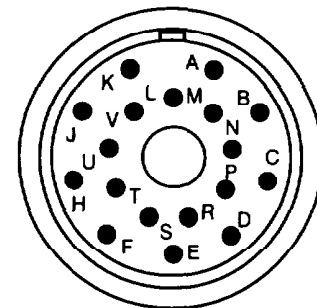

CX-13292 P1/P2

3.2. TROUBLESHOOTING FLOWCHARTS. Continued

Chart 20

RT SIG DISPLAY DOES NOT LIGHT WHEN LS-671 PTT IS PRESSED.

(Sheet 3 of 3)

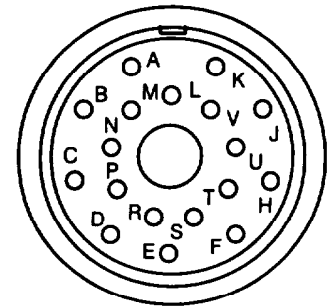
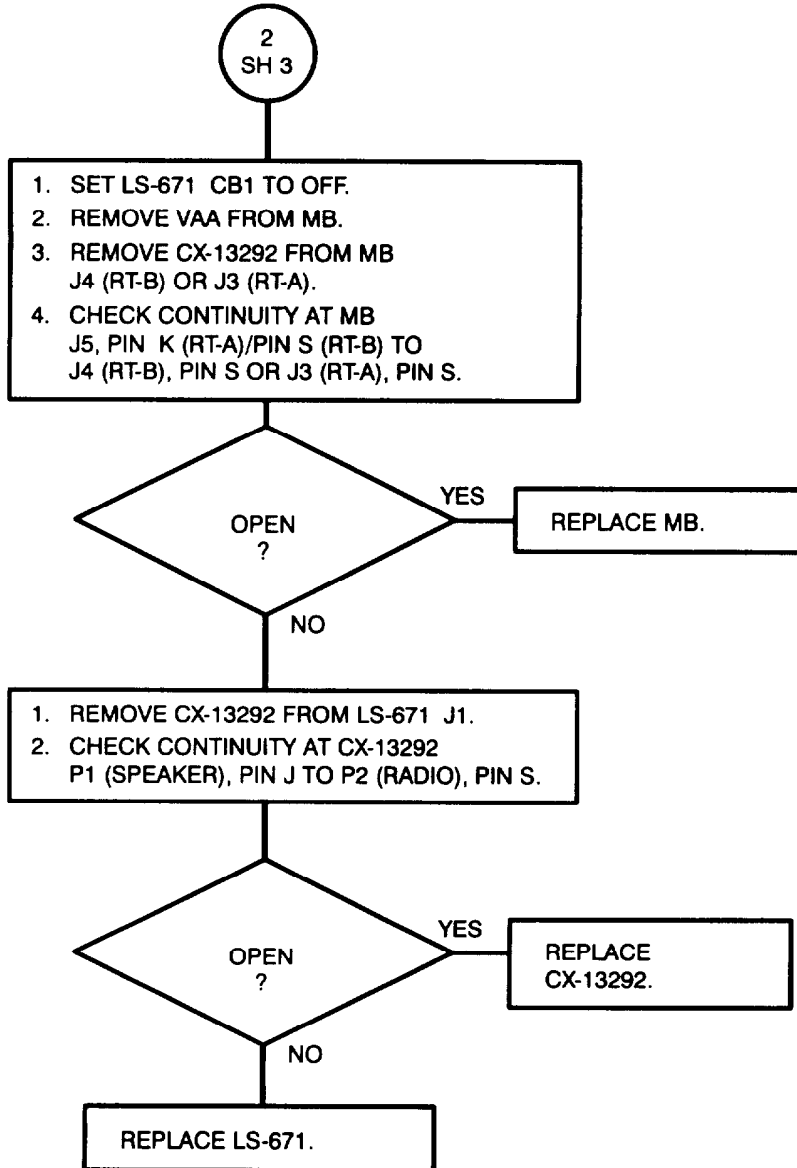

MB J3/J4

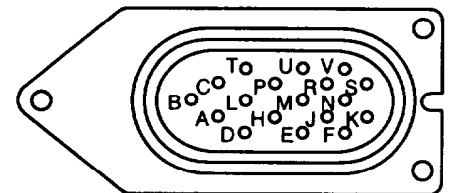

MB J5

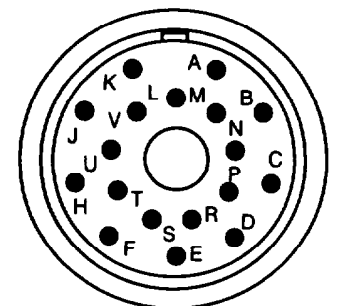

CX-13292 P1/P2

3.2. TROUBLESHOOTING FLOWCHARTS. Continued

Chart 21

NO SIDETONE HEARD AT LS-671.  
(Sheet 1 of 3)

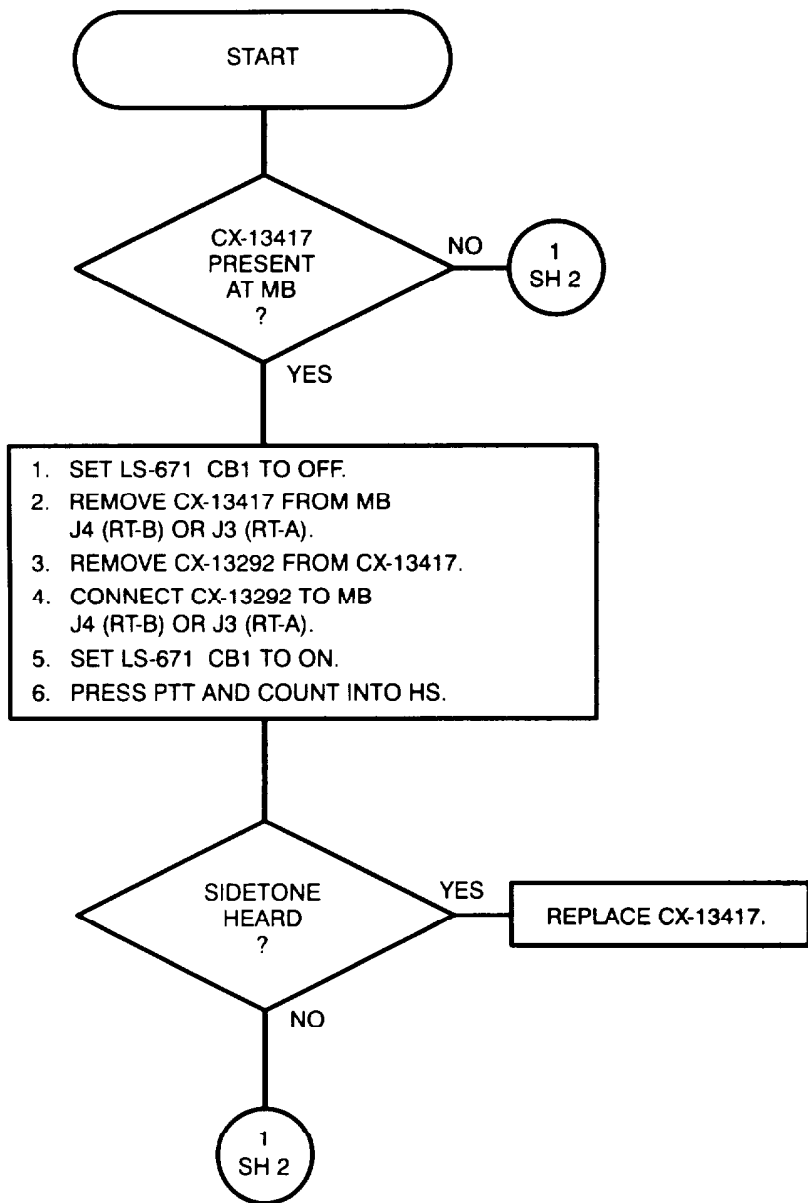

3.2. TROUBLESHOOTING FLOWCHARTS. Continued

Chart 21

NO SIDETONE HEARD AT LS-671.

(Sheet 2 of 3)

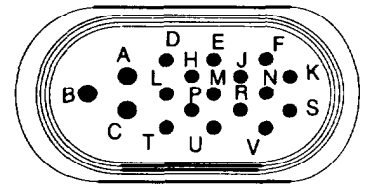
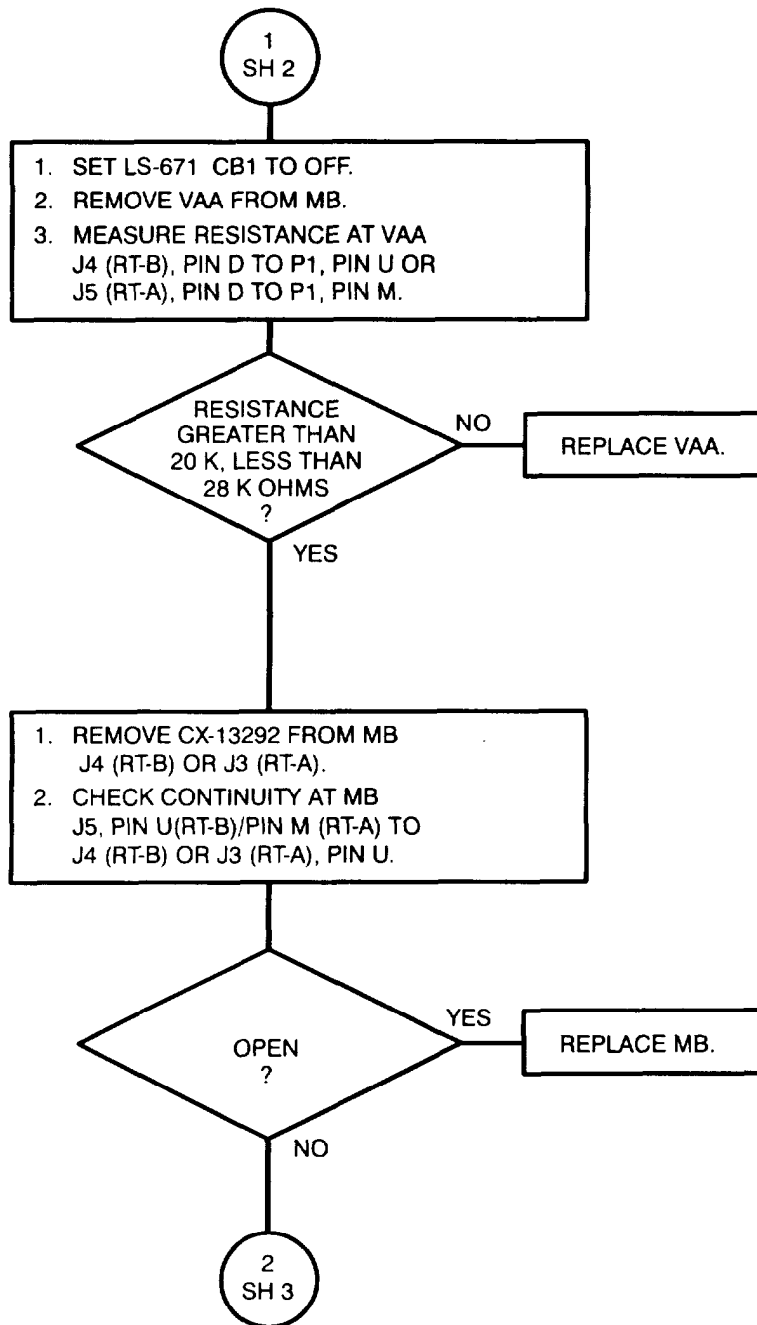

VAA P1

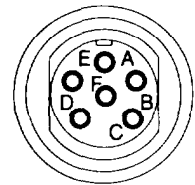

VAA J4/J5

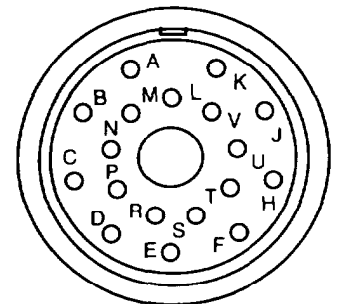

MB J3/J4

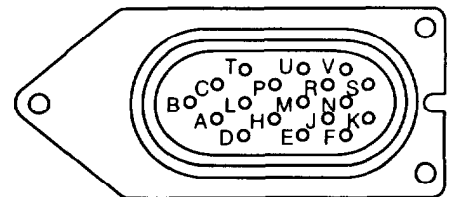

MB J5

3.2. TROUBLESHOOTING FLOWCHARTS. Continued

Chart 21

NO SIDETONE HEARD AT LS-671.

(Sheet 3 of 3)

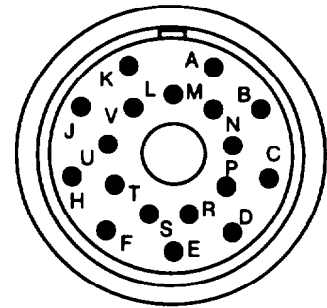
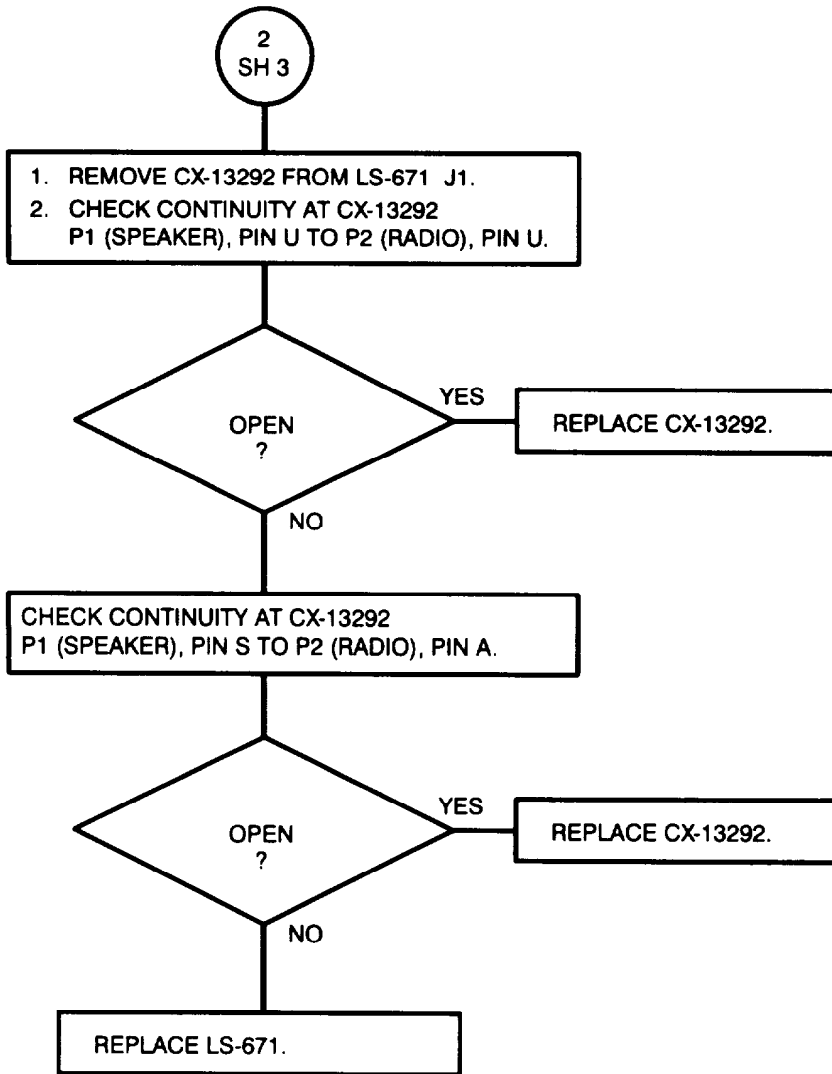

CX-13292 P1/P2



3.2. TROUBLESHOOTING FLOWCHARTS. Continued

Chart 22

RADIO WILL NOT OPERATE WITH DATA DEVICES.  
(Sheet 1 of 2)

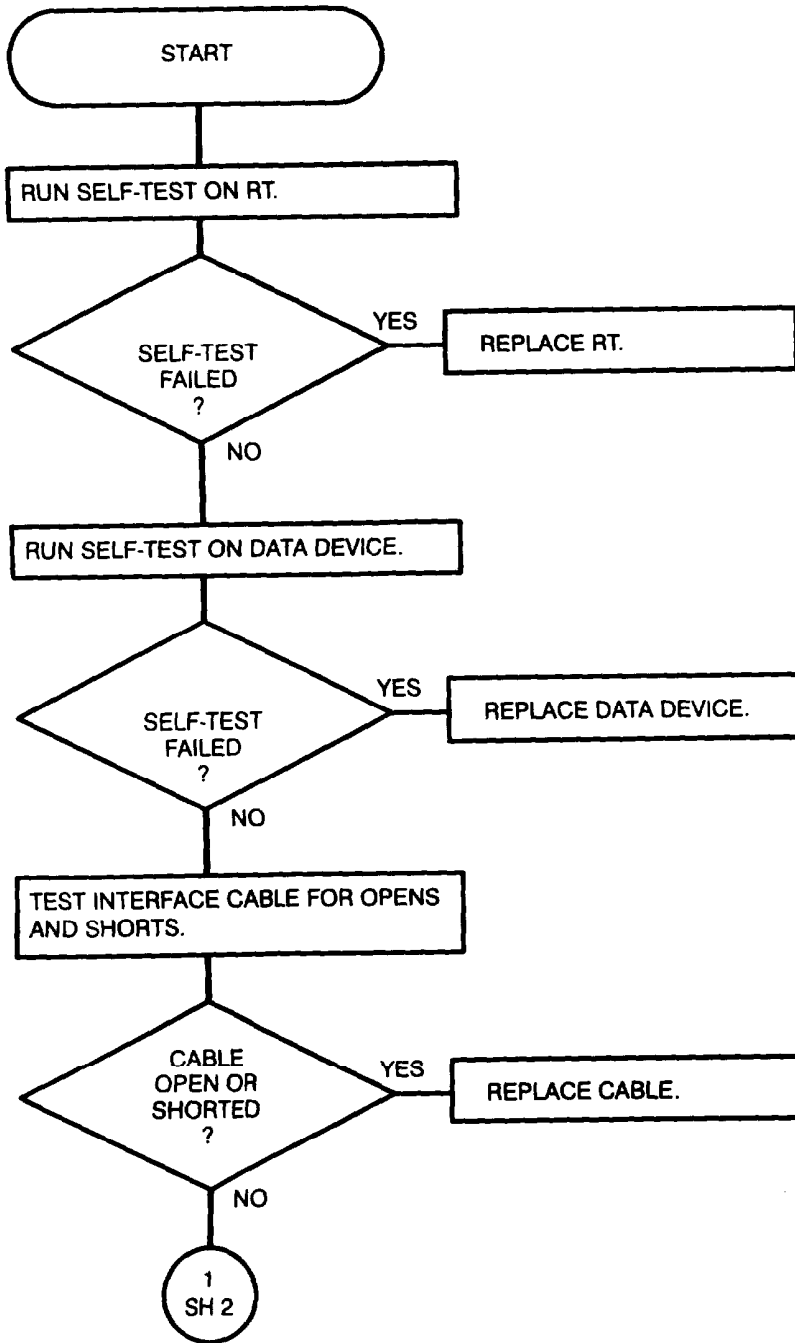

**NOTE:**

Data devices may be any type equipment which meets the RT data specifications.

3.2. TROUBLESHOOTING FLOWCHARTS. Continued

Chart 22

RADIO WILL NOT OPERATE WITH DATA DEVICES.

(Sheet 2 of 2)

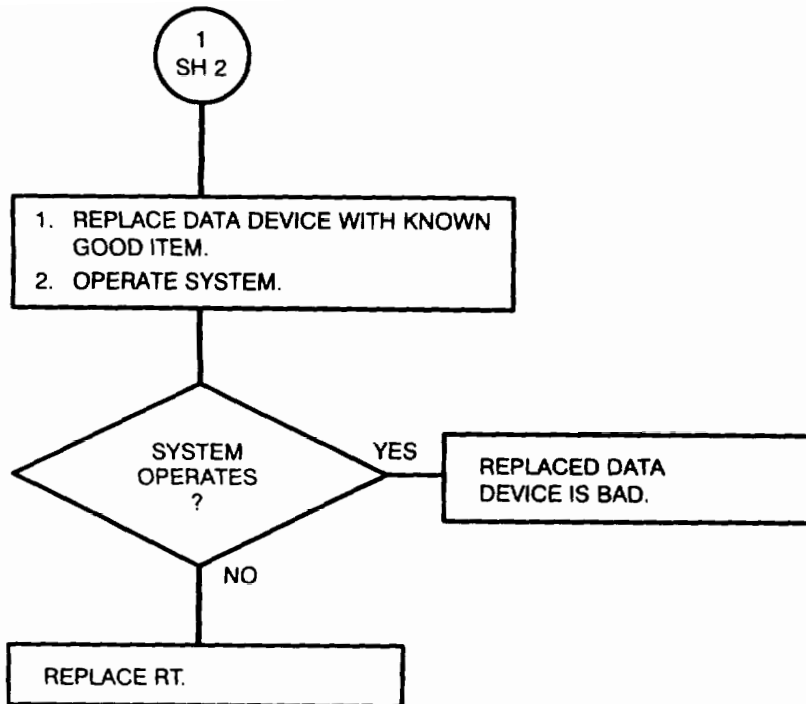

**NOTE:**

If a data device is not available, replace the RT. If the system operates, the replaced RT is bad.

3.2. TROUBLESHOOTING FLOWCHARTS. Continued

**CHART 23**  
**RCU DISPLAY READS "OPEN" DURING SELF-TEST.**  
 (Sheet 1 of 8)

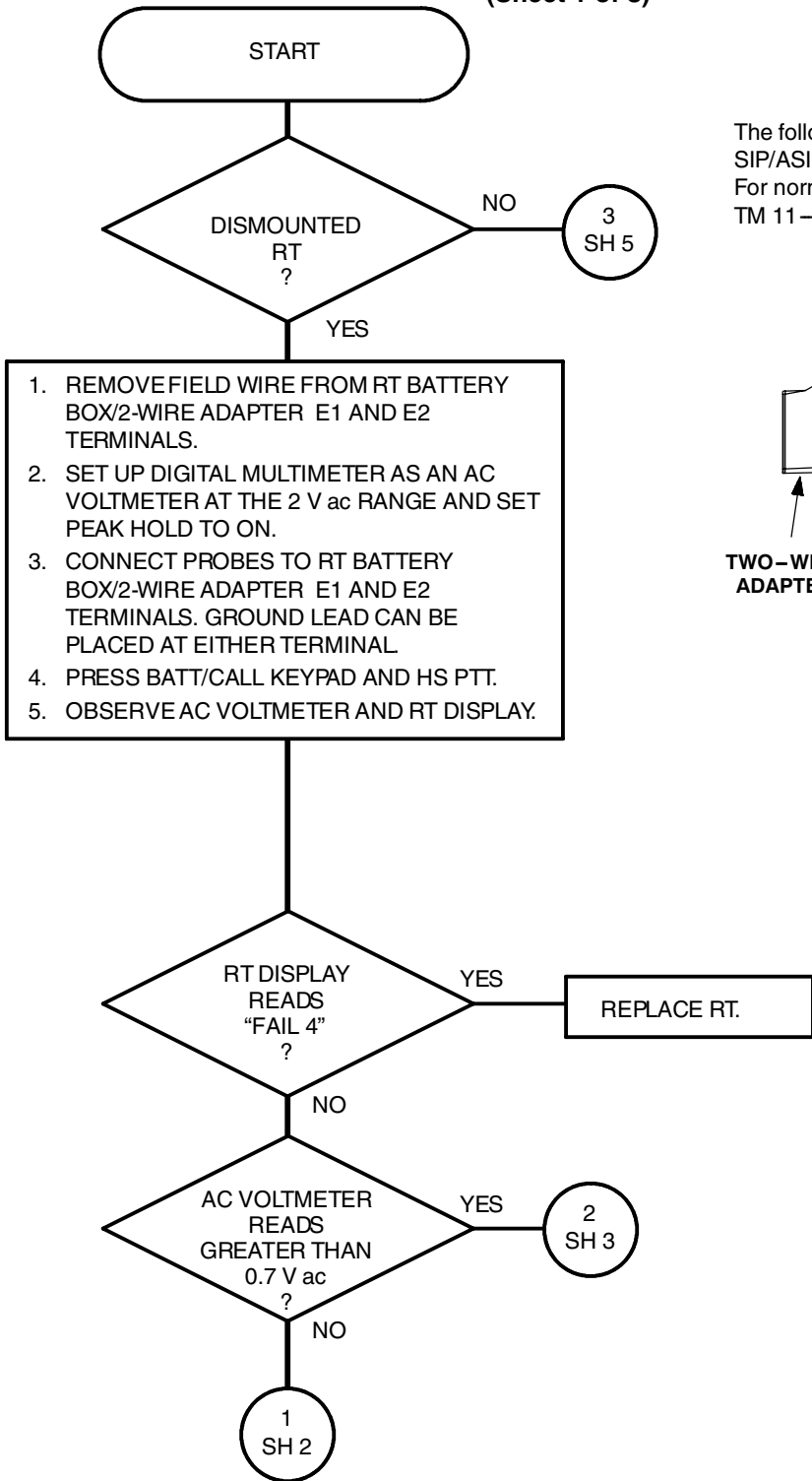

**NOTE:**

The following TS CHARTS 23 – 28 are for a SIP/ASIP radio being used as an RCU. For normal RCU (C-11561) see TM 11-5820-890-20-2.

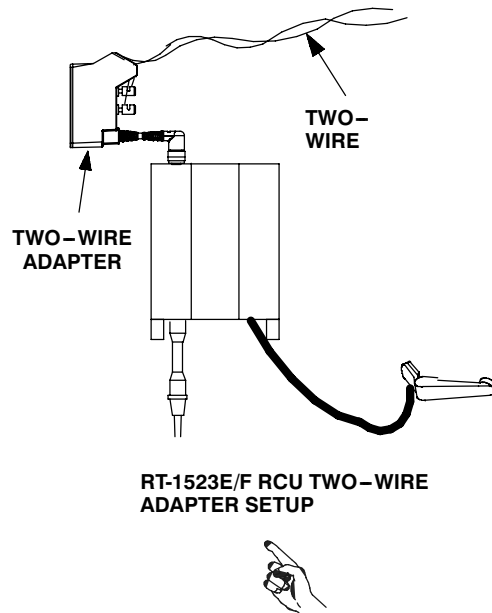

3.2. TROUBLESHOOTING FLOWCHARTS. Continued

CHART 23  
RCU DISPLAY READS "OPEN" DURING SELF-TEST.  
(Sheet 2 of 8)

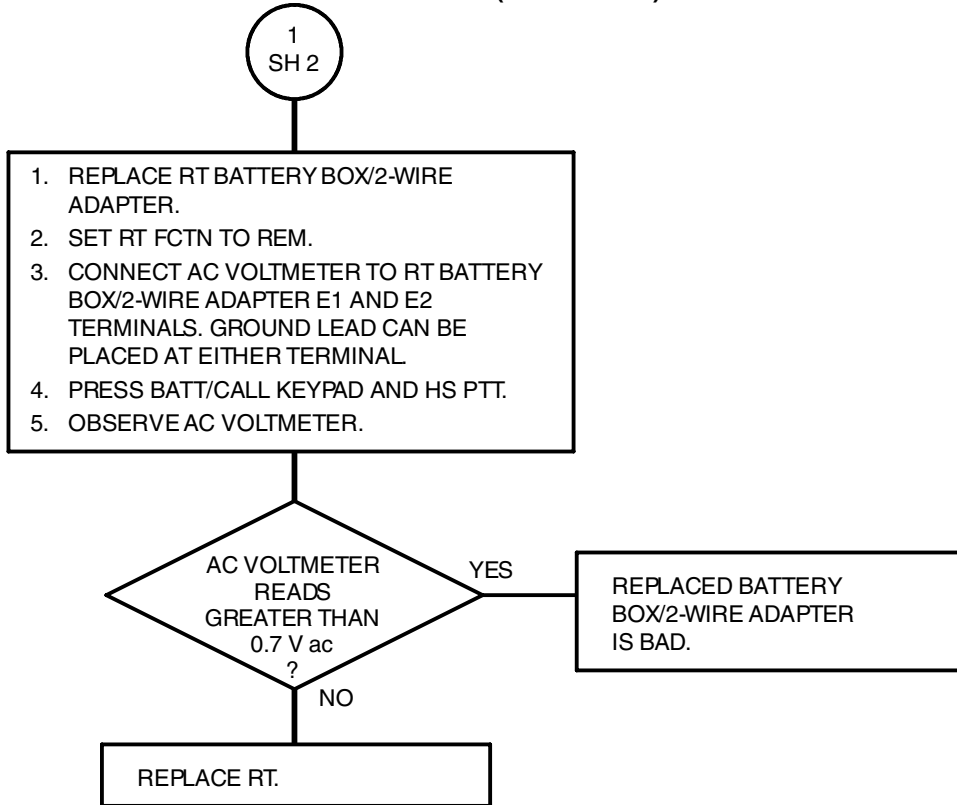

3.2. TROUBLESHOOTING FLOWCHARTS. Continued

**CHART 23**  
**RCU DISPLAY READS "OPEN" DURING SELF-TEST.**  
 (Sheet 3 of 8)

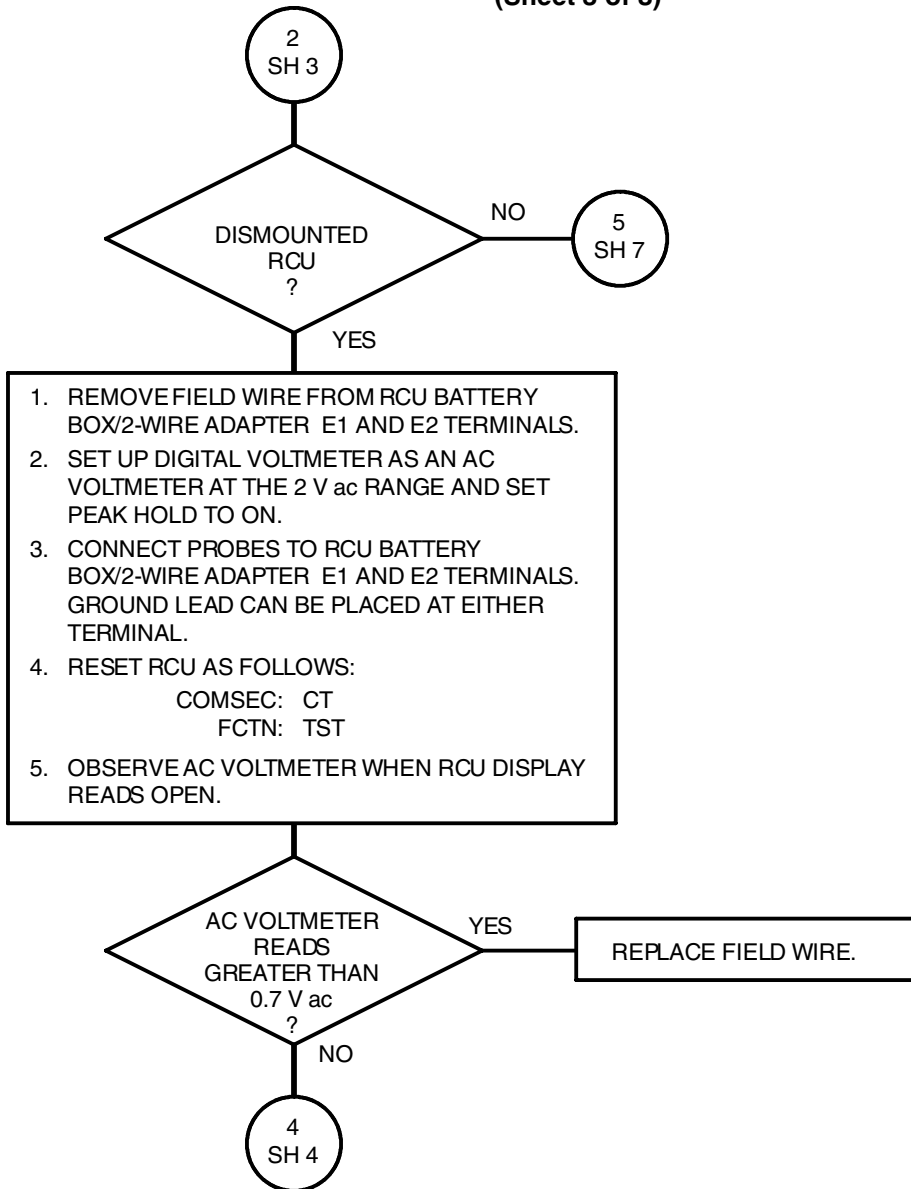

3.2. TROUBLESHOOTING FLOWCHARTS. Continued

CHART 23  
RCU DISPLAY READS "OPEN" DURING SELF-TEST.  
(Sheet 4 of 8)

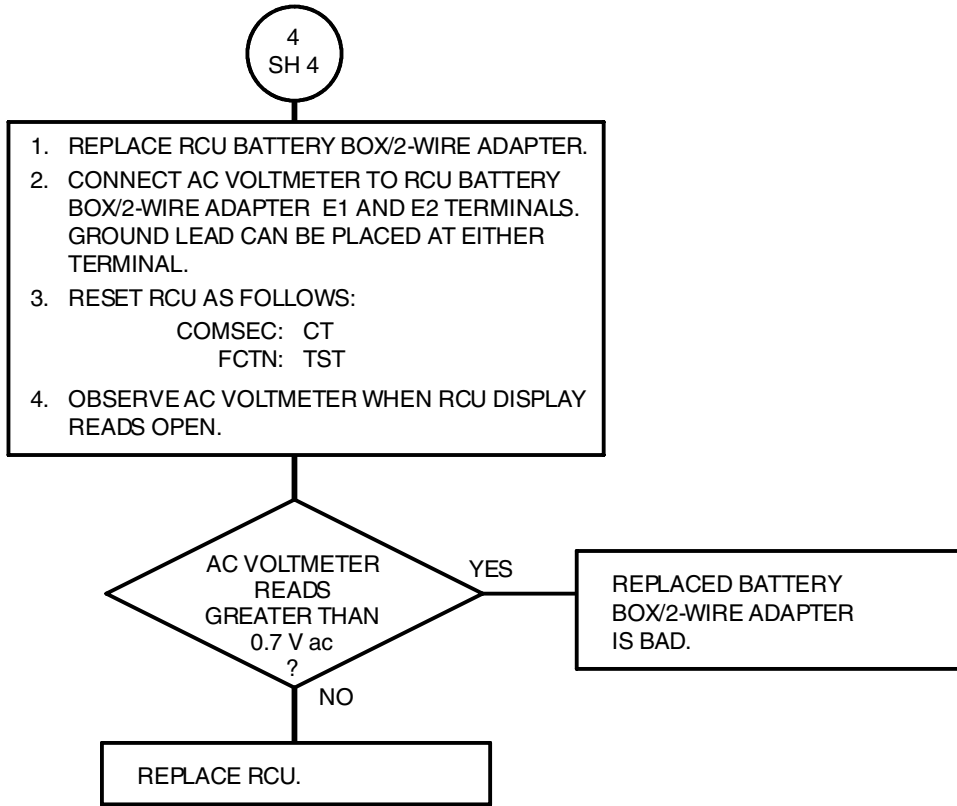

3.2. TROUBLESHOOTING FLOWCHARTS. Continued

**CHART 23**  
**RCU DISPLAY READS "OPEN" DURING SELF-TEST.**  
 (Sheet 5 of 8)

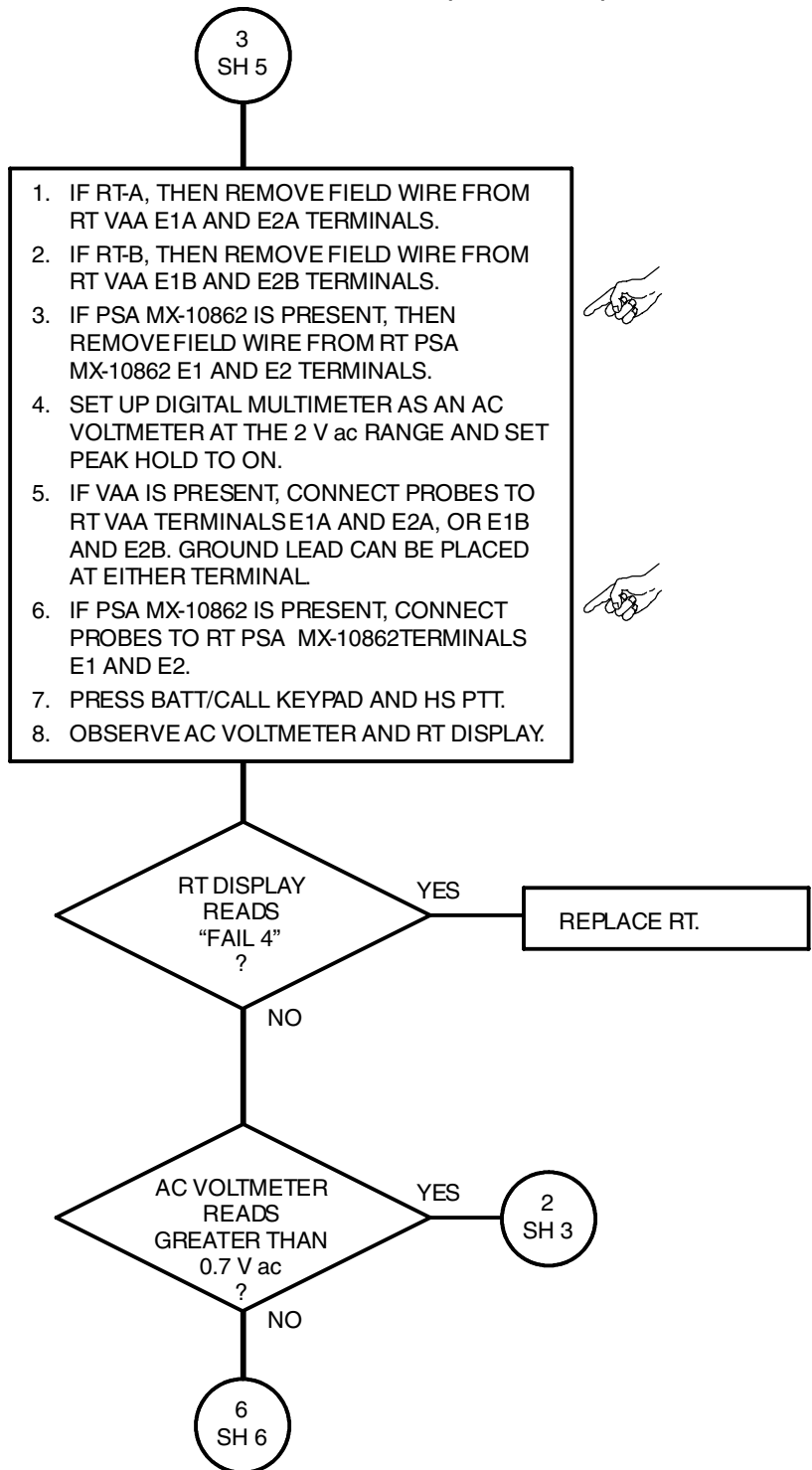

3.2. TROUBLESHOOTING FLOWCHARTS. Continued

CHART 23  
 RCU DISPLAY READS "OPEN" DURING SELF-TEST.  
 (Sheet 6 of 8)

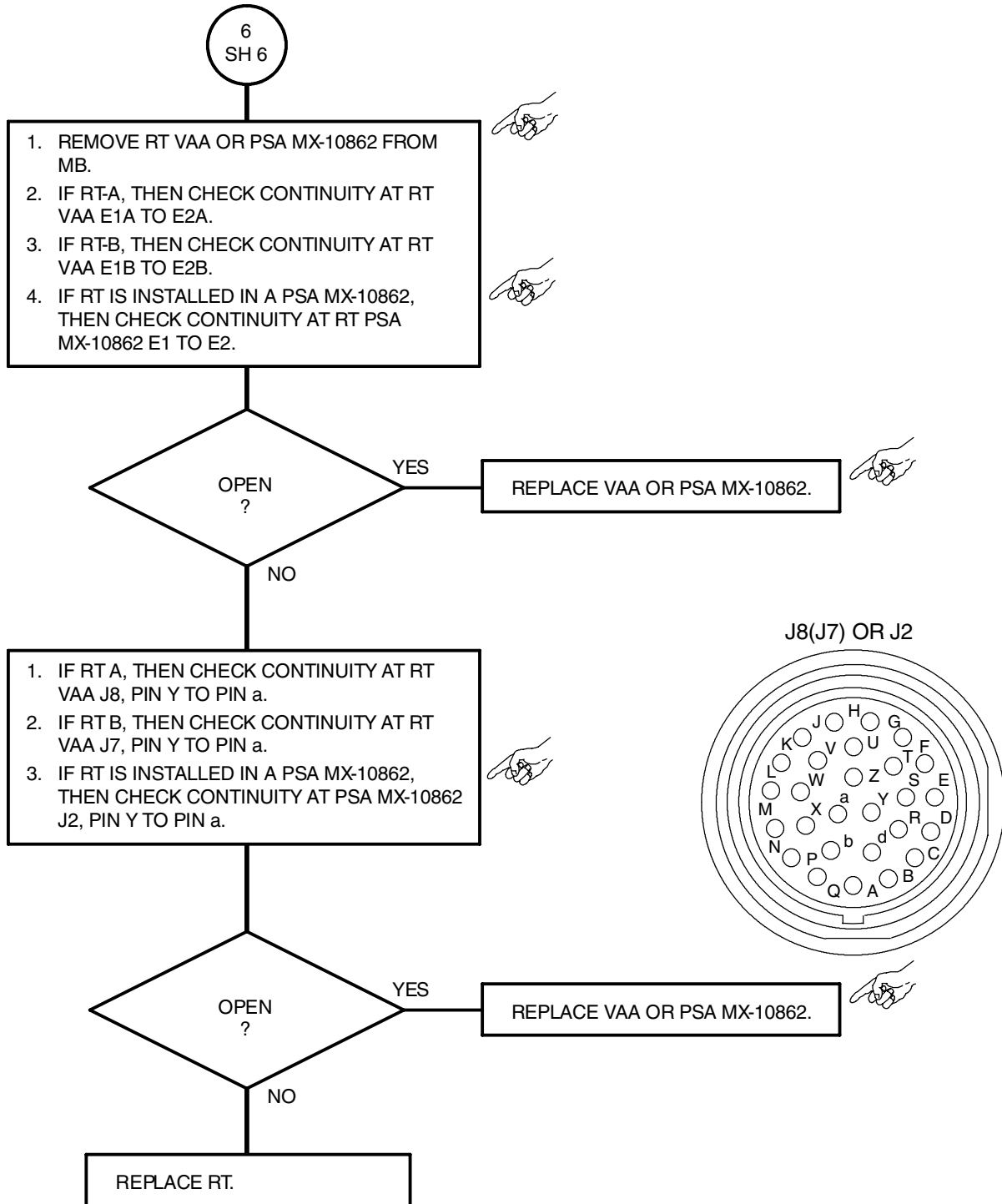



3.2. TROUBLESHOOTING FLOWCHARTS. Continued

**CHART 23**  
**RCU DISPLAY READS "OPEN" DURING SELF-TEST.**  
 (Sheet 7 of 8)

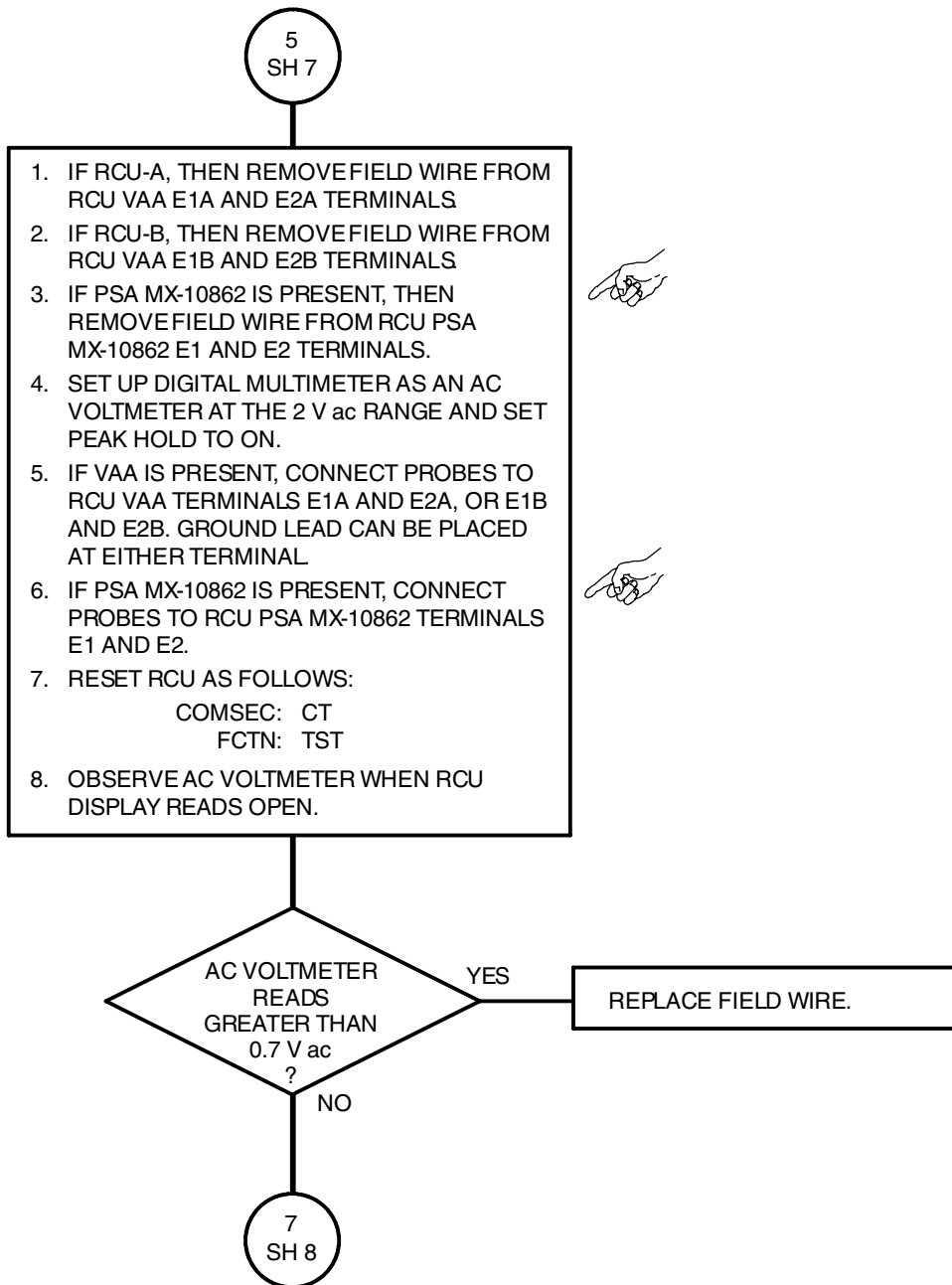

3.2. TROUBLESHOOTING FLOWCHARTS. Continued

**CHART 23**  
**RCU DISPLAY READS "OPEN" DURING SELF-TEST.**  
 (Sheet 8 of 8)

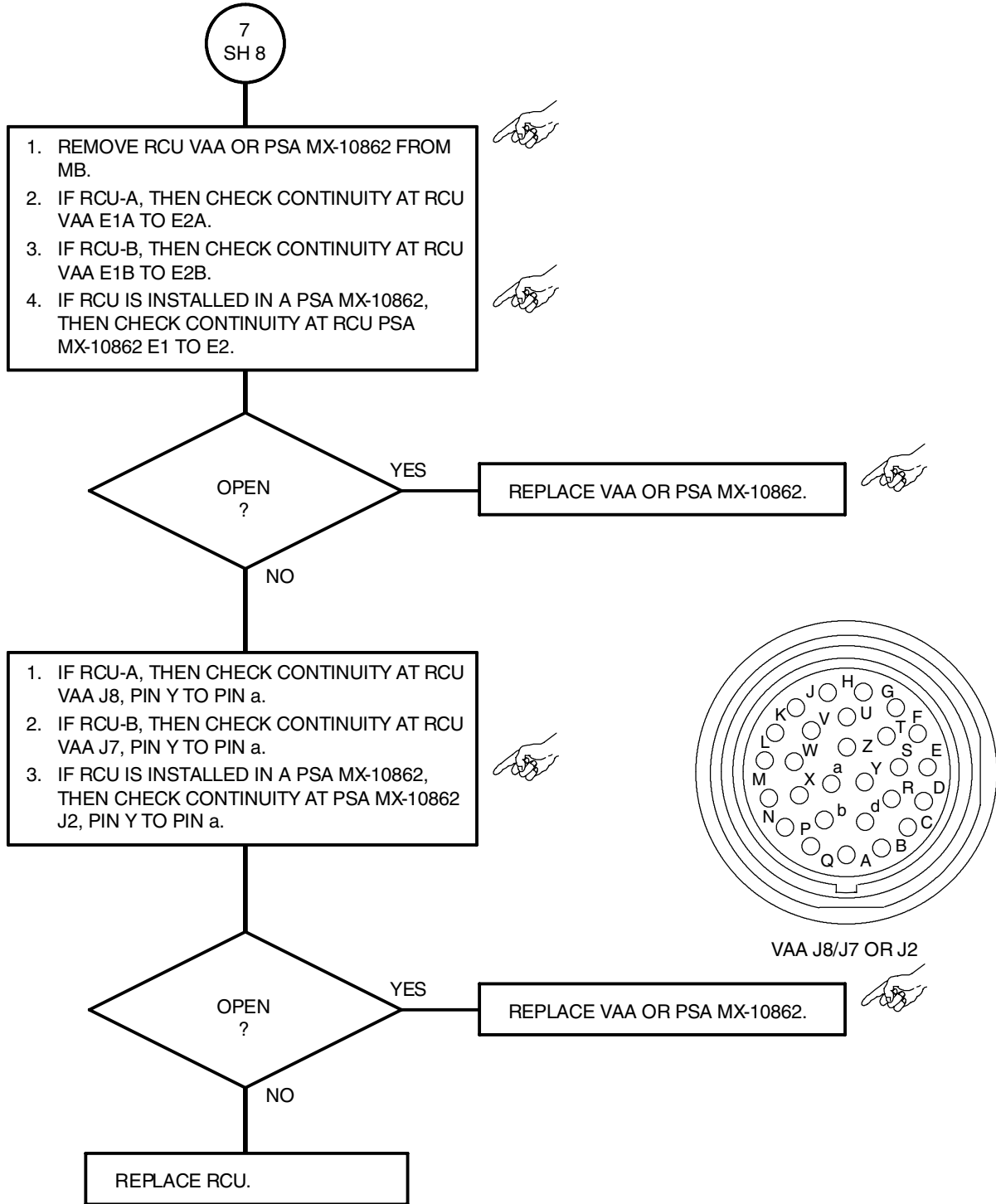

3.2. TROUBLESHOOTING FLOWCHARTS. Continued

CHART 24  
RT WILL NOT LOAD FREQUENCIES FROM RCU.  
(Sheet 1 of 1)

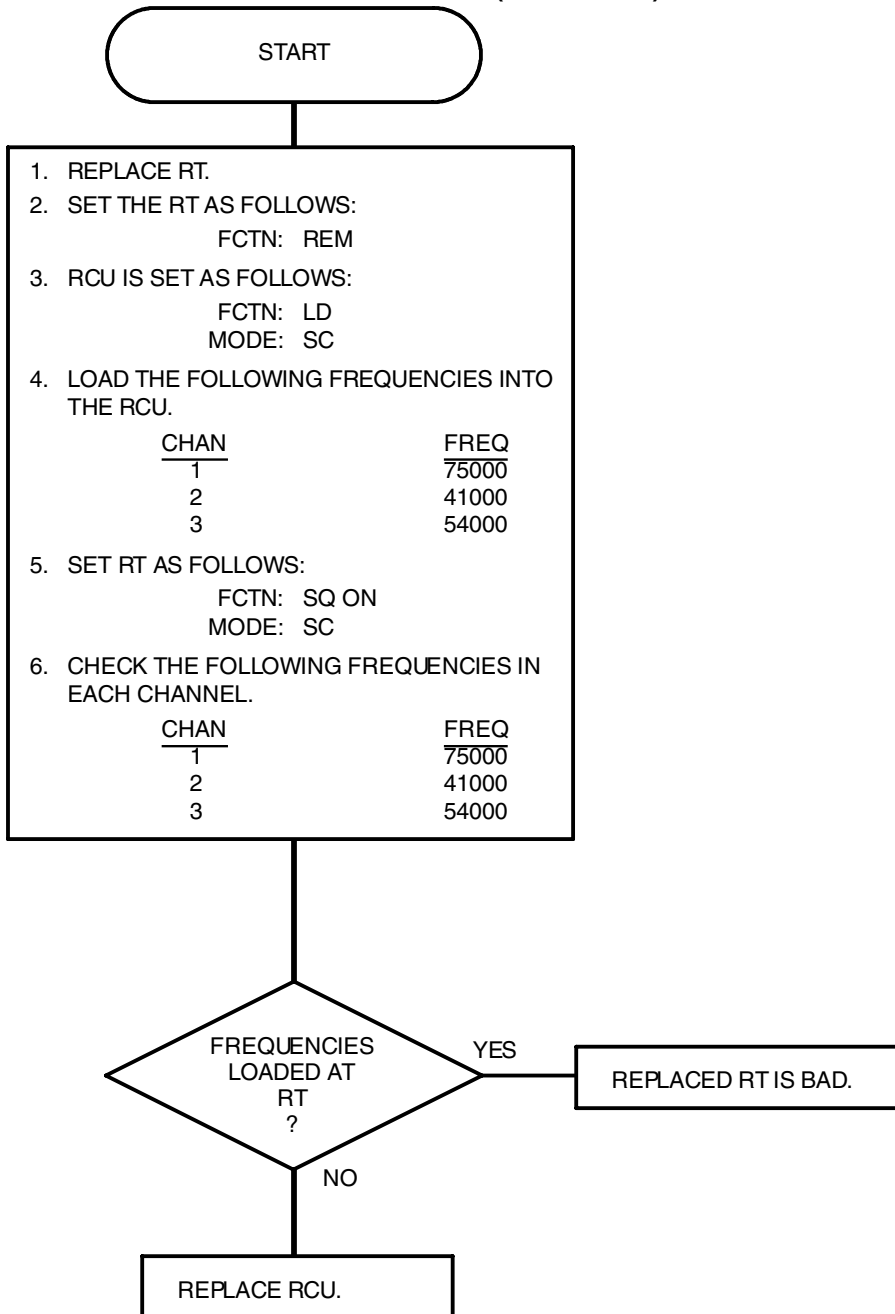

3.2. TROUBLESHOOTING FLOWCHARTS. Continued

CHART 25  
NO CALL FUNCTION AT THE RCU.  
(Sheet 1 of 2)

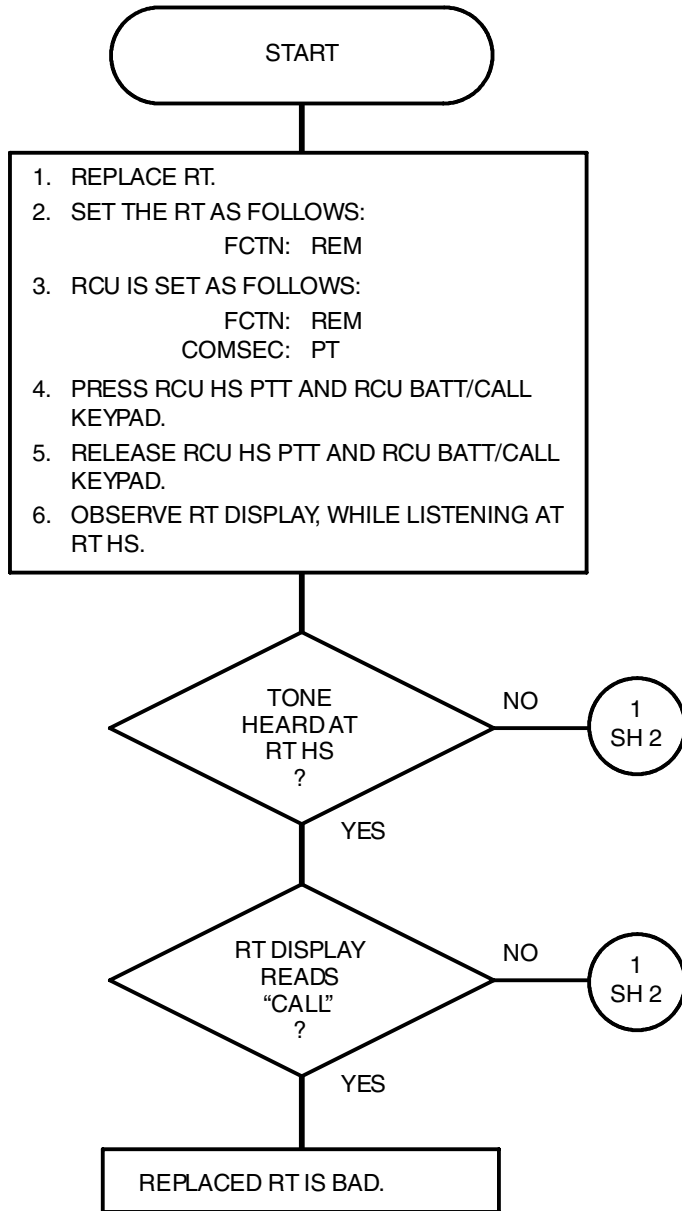

**NOTE:**

It may take up to 12 seconds before the RT display will display "CALL".

3.2. TROUBLESHOOTING FLOWCHARTS. Continued

CHART 25  
NO CALL FUNCTION AT THE RCU.  
(Sheet 2 of 2)

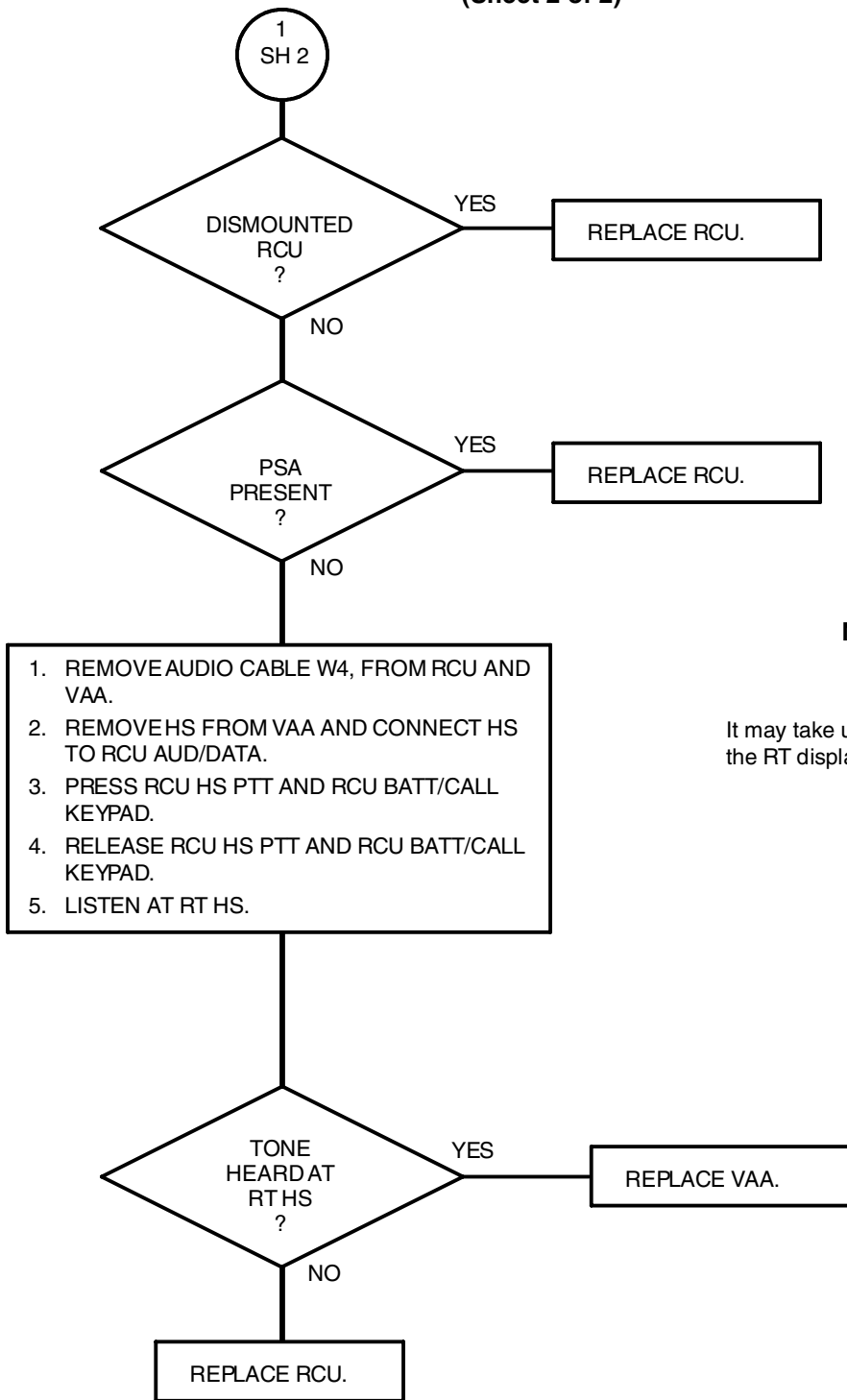

**NOTE:**

It may take up to 12 seconds before the RT display will display "CALL".

3.2. TROUBLESHOOTING FLOWCHARTS. Continued

CHART 26  
NO INTERCOM TALK FUNCTION FROM RCU TO RT.  
(Sheet 1 of 2)

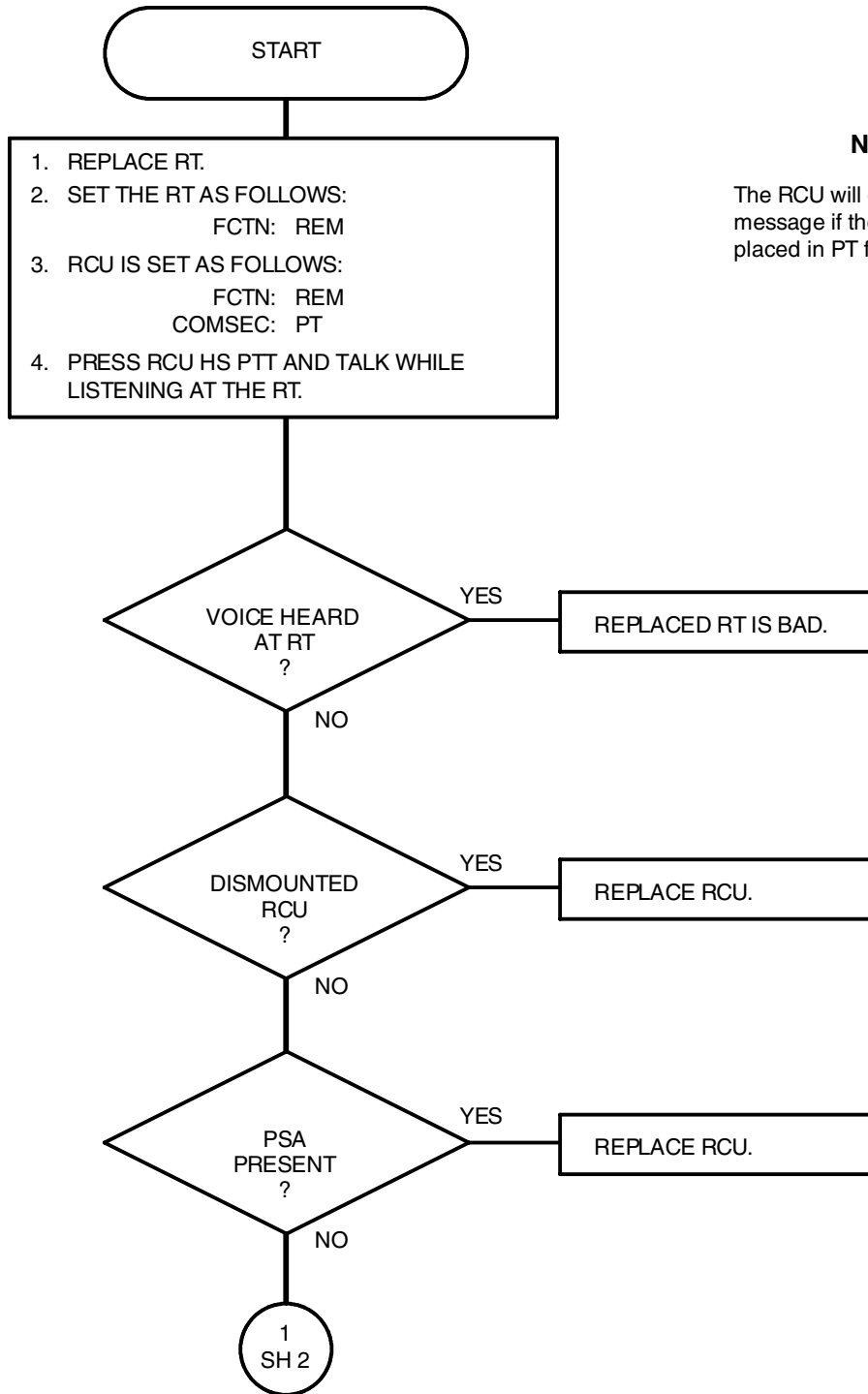

**NOTE:**

The RCU will display an ERROR message if the COMSEC switch is not placed in PT for the intercom function.

3.2. TROUBLESHOOTING FLOWCHARTS. Continued

CHART 26  
NO INTERCOM TALK FUNCTION FROM RCU TO RT.  
(Sheet 2 of 2)

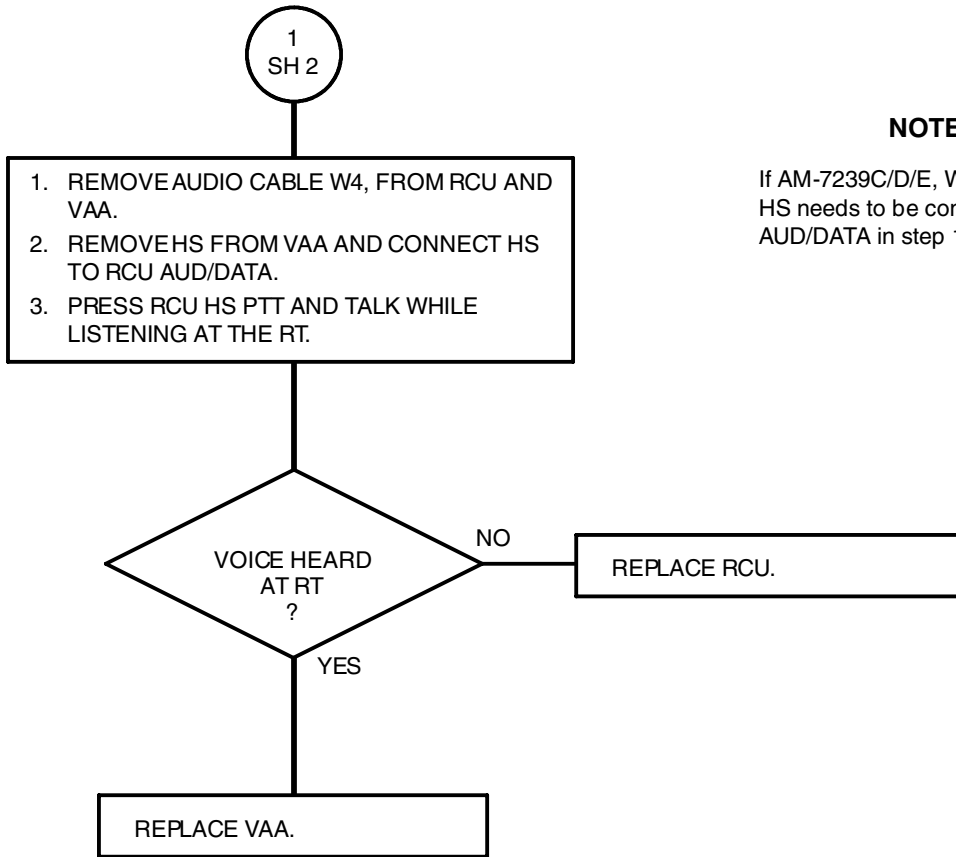

**NOTE:**

If AM-7239C/D/E, W4 may not be present. HS needs to be connected to RT AUD/DATA in step 1.

3.2. TROUBLESHOOTING FLOWCHARTS. Continued

CHART 27  
NO CALL FUNCTION AT THE RT.  
(Sheet 1 of 1)

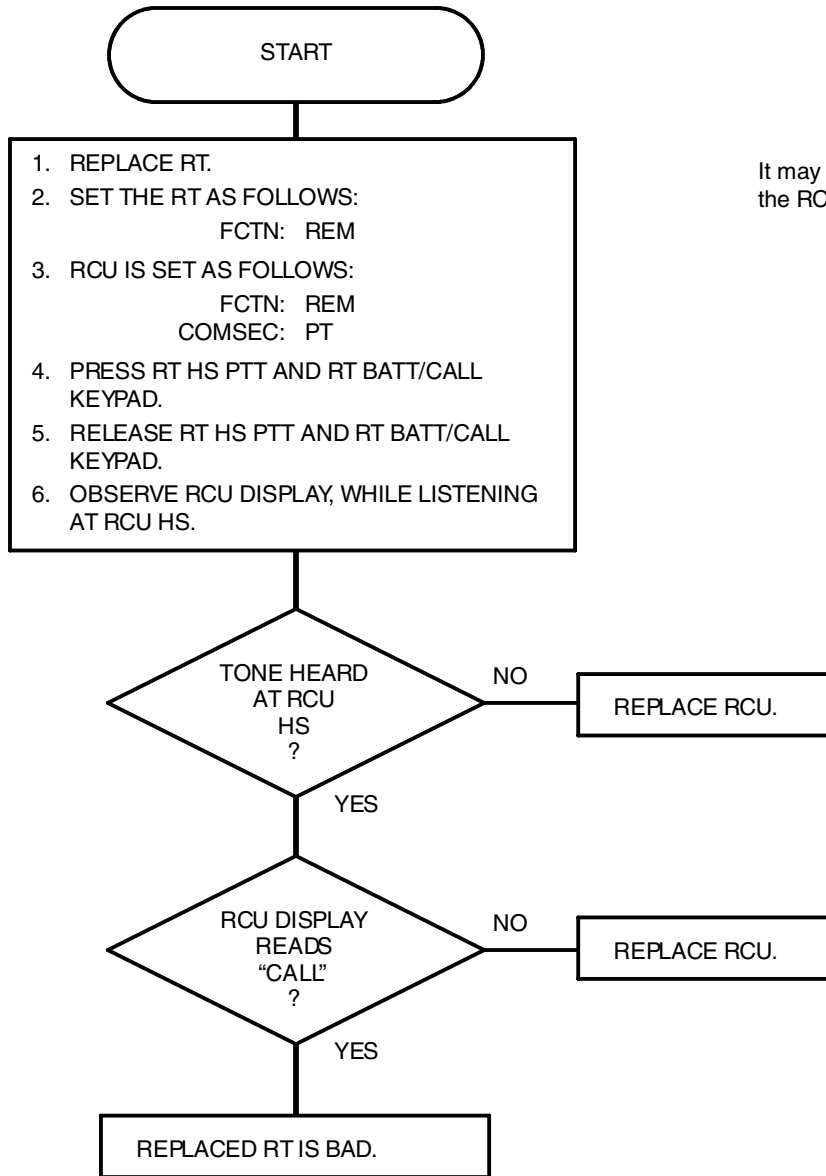

**NOTE:**

It may take up to 12 seconds before the RCU display will display CALL.



3.2. TROUBLESHOOTING FLOWCHARTS. Continued

CHART 28  
NO INTERCOM TALK FUNCTION FROM RT TO RCU.  
(Sheet 1 of 1)

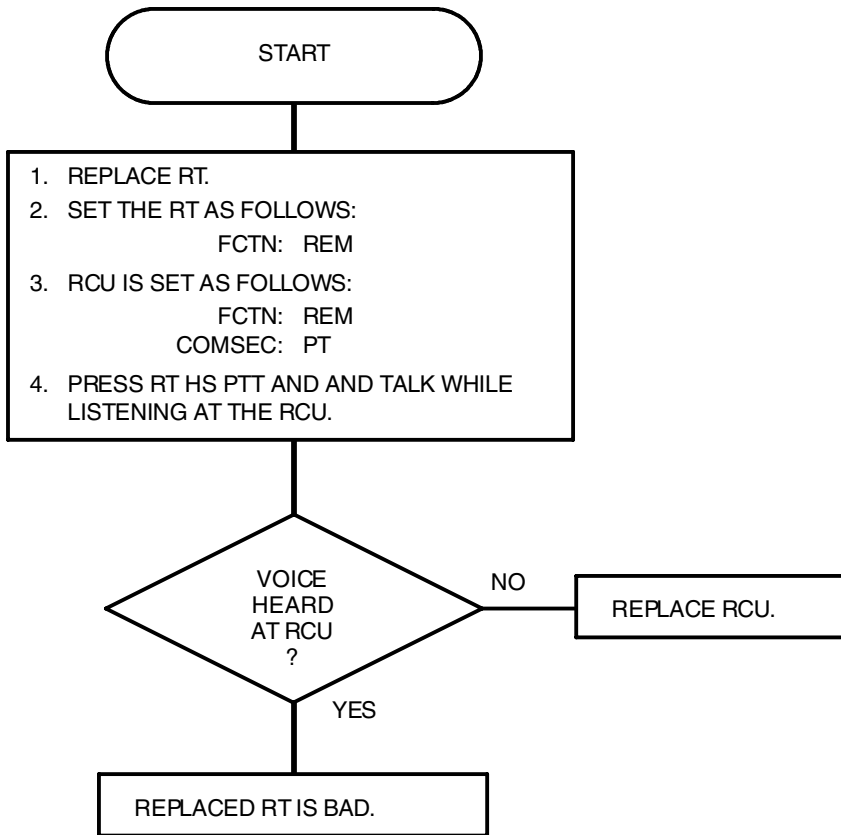

3.2. TROUBLESHOOTING FLOWCHARTS. Continued

CHART 29  
CDU DISPLAY DOES NOT LIGHT.  
(Sheet 1 of 1)

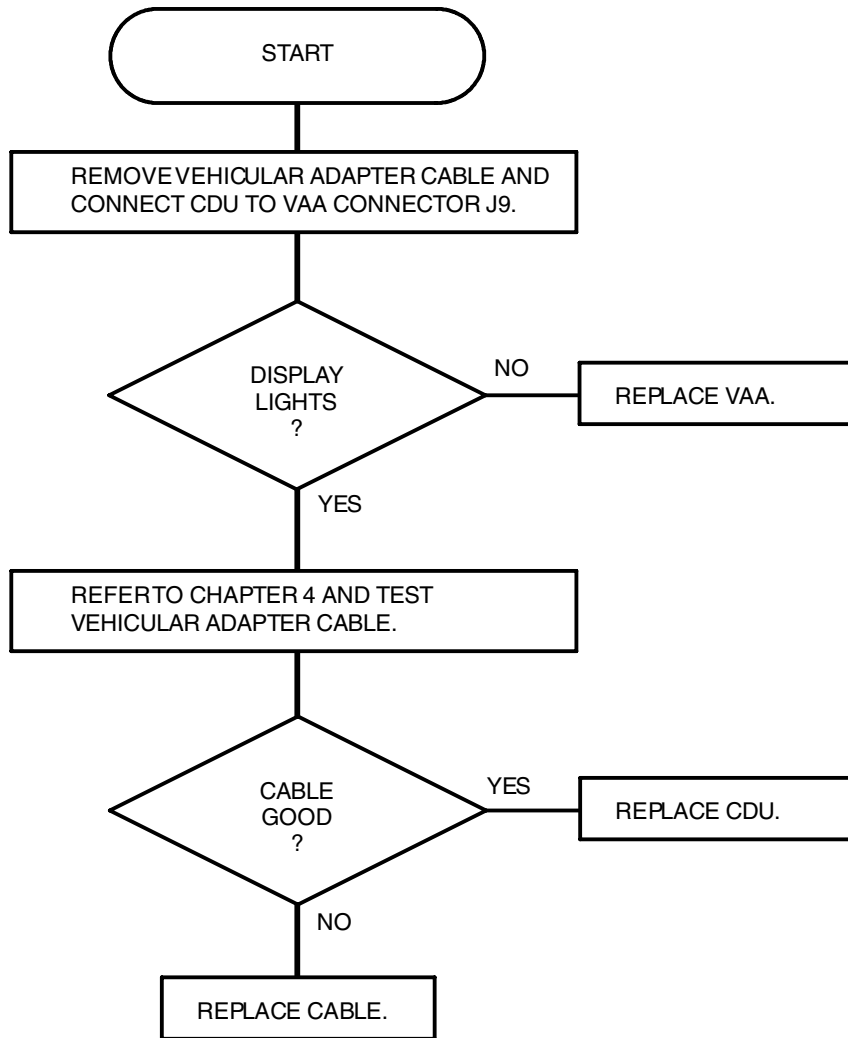

3.2. TROUBLESHOOTING FLOWCHARTS. Continued

CHART 30  
CDU FEATURES DO NOT WORK.  
(Sheet 1 of 1)

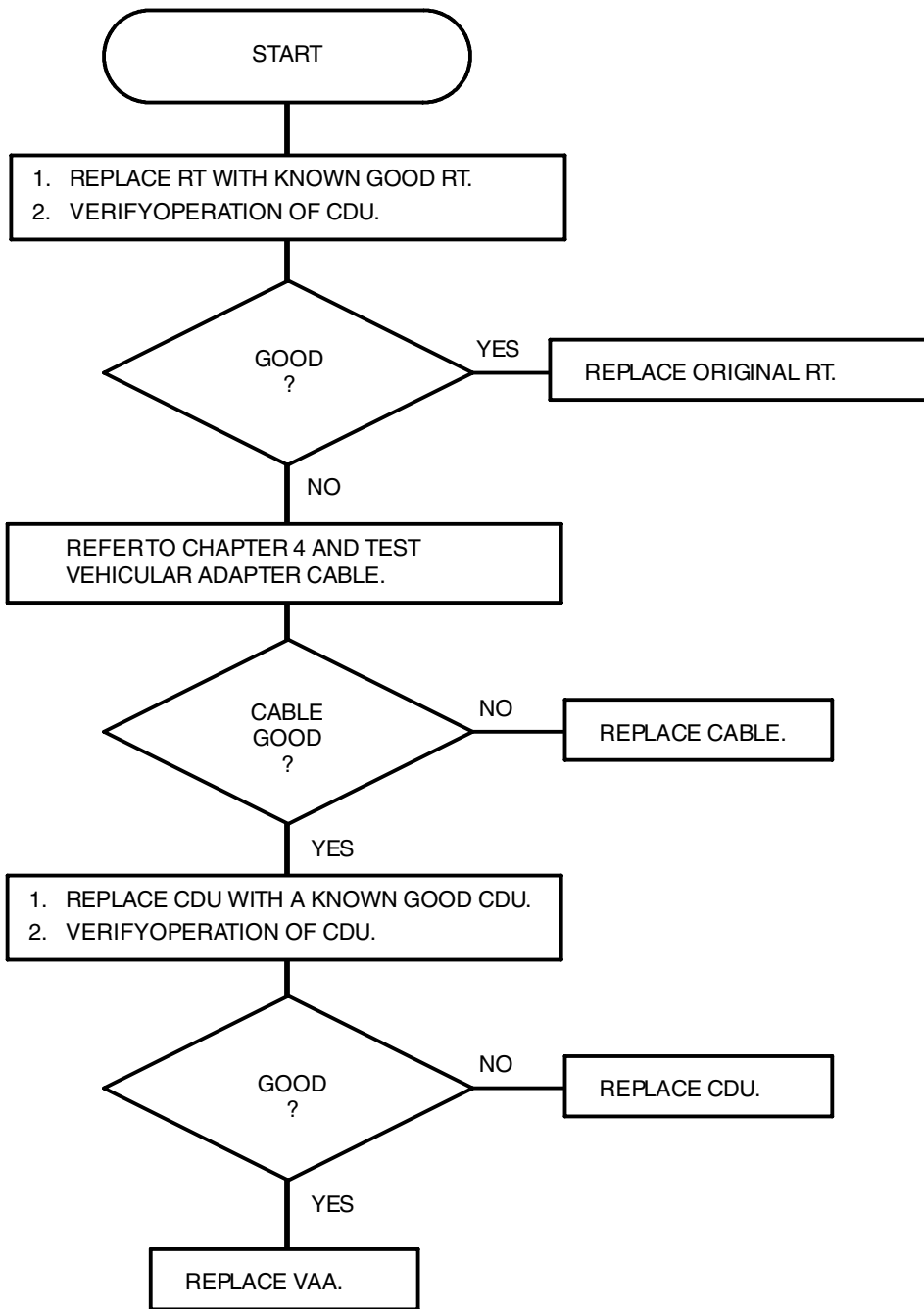



## CHAPTER 4

### CABLES

Subject	Para	Page
Troubleshooting Cables .....	4.1	4-1
Cable Schematics .....	4.2	4-3

#### 4.1. TROUBLESHOOTING CABLES.

- a. General. Troubleshoot cables as an integral part of any radio system. The VIC interface cable (CX-13313) and splitter cable (CX-13417) contain some components which cannot be checked with the test equipment available to the unit maintainer. Other cables that cannot be repaired at this level are: CX-13310, CX-13311, and CX-13312. These cables must be sent to DS Maintenance to be completely tested.

**NOTE**

Paragraph 4.2 Cable Schematics, provides additional details regarding cable pins, connections, and shielding.

**b. Testing**

**(1) Continuity Test Procedure:**

- (a) Disconnect cable from system being checked.
- (b) Set Multimeter (1) for continuity check (lowest ohm range).
- (c) Connect one test lead (2) to pin of connector (3) to be tested.
- (d) Connect other test lead to same pin of other connector (see Cable Schematics for details).
- (e) Cable is good if Multimeter (1) reads ZERO/short. Cable may be defective if Multimeter reads other than ZERO/short; inspect for breaks, bad pins, loose connections, **but do not attempt to repair cables.**
- (f) Replace faulty cable with a new or known good one.

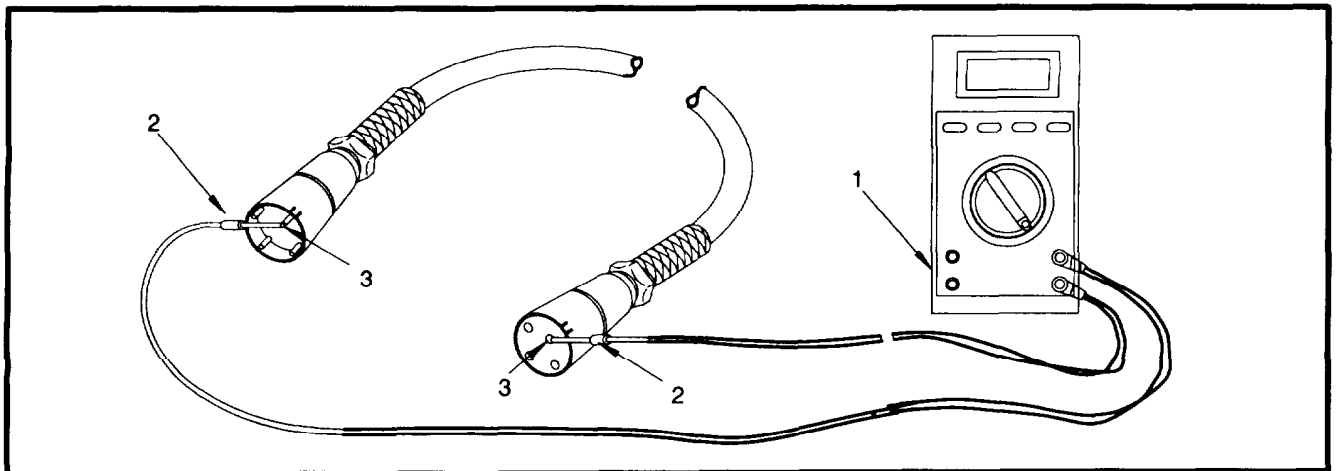

#### 4.1. TROUBLESHOOTING CABLES. Continued

##### (2) Short to Ground Test Procedure:

- (a) Disconnect cable from system being checked.
- (b) Set Multimeter (1) for continuity check (highest ohm range).
- (c) Connect one test lead (2) to each pin, of connector (3), one at a time.
- (d) Connect other test lead to outer casing of connector (see Cable Schematics for details).
- (e) Cable is good if Multimeter reads INFINITY/open. Cable may be defective and must be replaced if Multimeter reads other than INFINITY/open.
- (f) Repeat steps (c) and (d) until all pins have been checked.

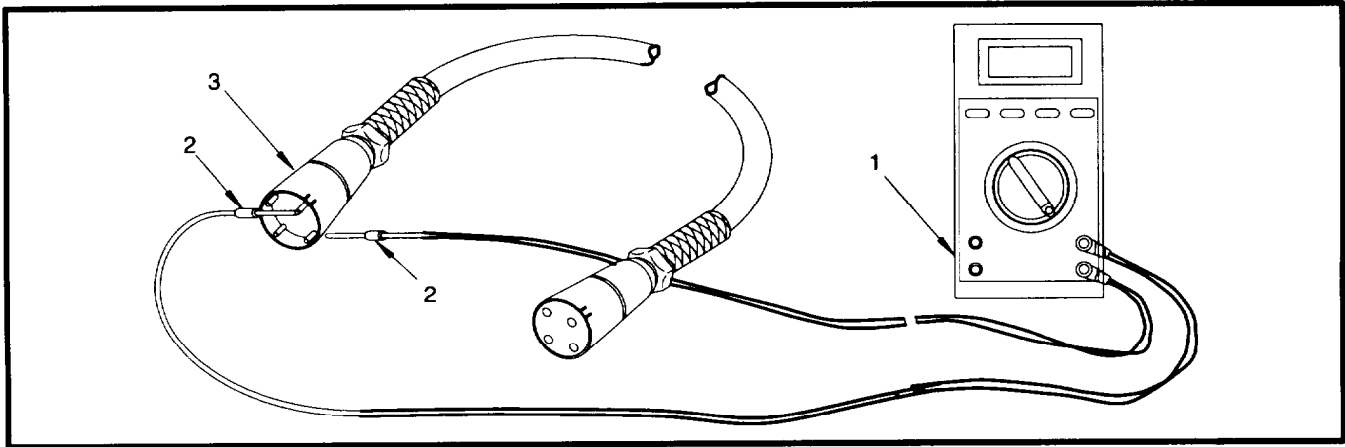

##### (3) Short Pin to Pin Test Procedure:

- (a) Disconnect cable from system being checked.
- (b) Set Multimeter (1) for continuity check (highest ohm range).
- (c) Connect one test lead (2) to each pin, of connector (3), one at a time.
- (d) Connect other test lead to another pin.
- (e) Cable is good if Multimeter reads INFINITY/open. Cable may be defective if reading is other than INFINITY/open (see Cable Schematics); if pins are not connected, replace cable.
- (9) Repeat steps (c) and (d) until all pins have been checked.

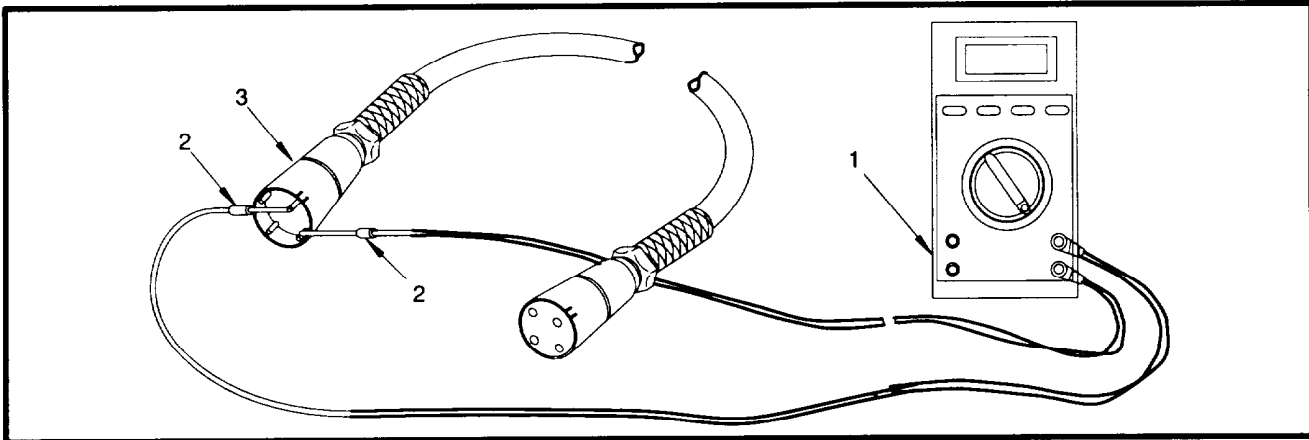

**4.2. SCHEMATICS.**

**a. Index of Cable Schematics.**

<b>COMMON NAME</b>	<b>NOMENCLATURE</b>	<b>PAGE</b>
RF Cable	CG-3855	4-4
RF Cable and W2	CG-3856	4-4
PA Control Cable	CX-13291	4-5
LS-671 Cable	CX-13292	4-6
RXMT Cable	CX-13298	4-7
Intercom Cable	CX-13300	4-8
M551 Power Cable	CX-13301	4-9
Power Cable	CX-13302	4-10
Power Cable	CX-13303	4-11
Power Cable	CX-13304	4-12
Power Cable	CX-13305	4-13
Power Cable	CX-13306	4-14
DMD Cable	CX-13308	4-15
HYX-57 Cable	CX-13310	4-16
MST-20 Adapter Cable	CX-13311	4-17
PSC-3 Adapter Cable	CX-13312	4-18
VIC Interface Cable	CX-13313	4-19
TACFIRE Magic Cable	CX-13402	4-20
Splitter Cable	CX-13417	4-21
Power Cable	CX-13450	4-22
Digital Adapter Cable	CX-13465	4-23
Audio/Data Cable	W4	4-24
GPS Fill Cable	W20	4-25
CDU Vehicular Adapter Cable	NA	4-26

4.2. SCHEMATICS. Continued

b. CG-3855 (RF Cable)

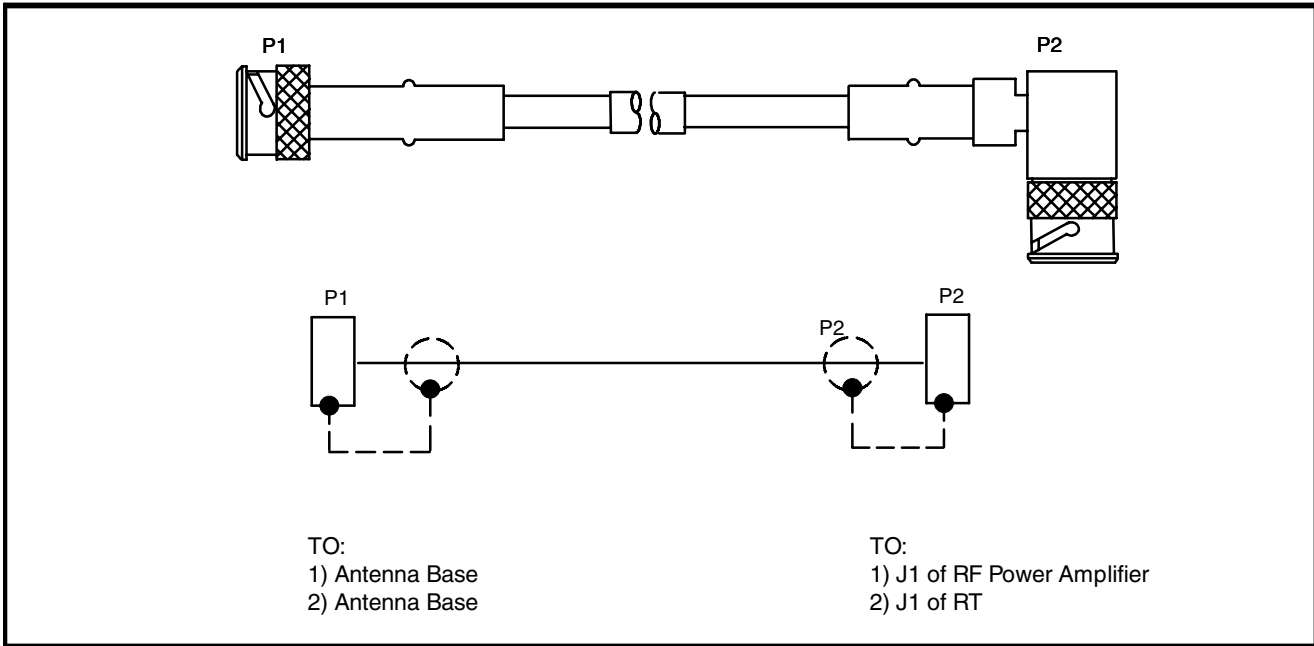

**CG-3855 (RF Cable)**

c. CG-3856 (RF Cable)\*

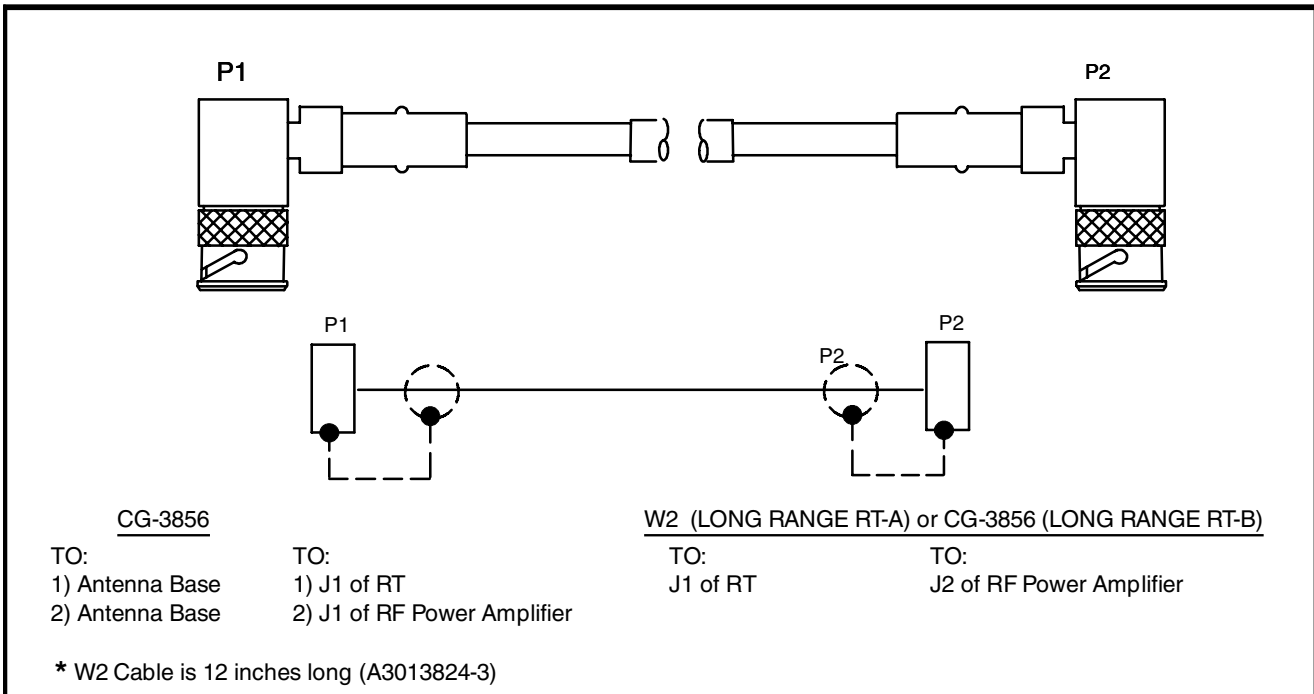

**CG-3856 (RF Cable)**



4.2. SCHEMATICS. Continued

d. CX-13291 (PA Control Cable)

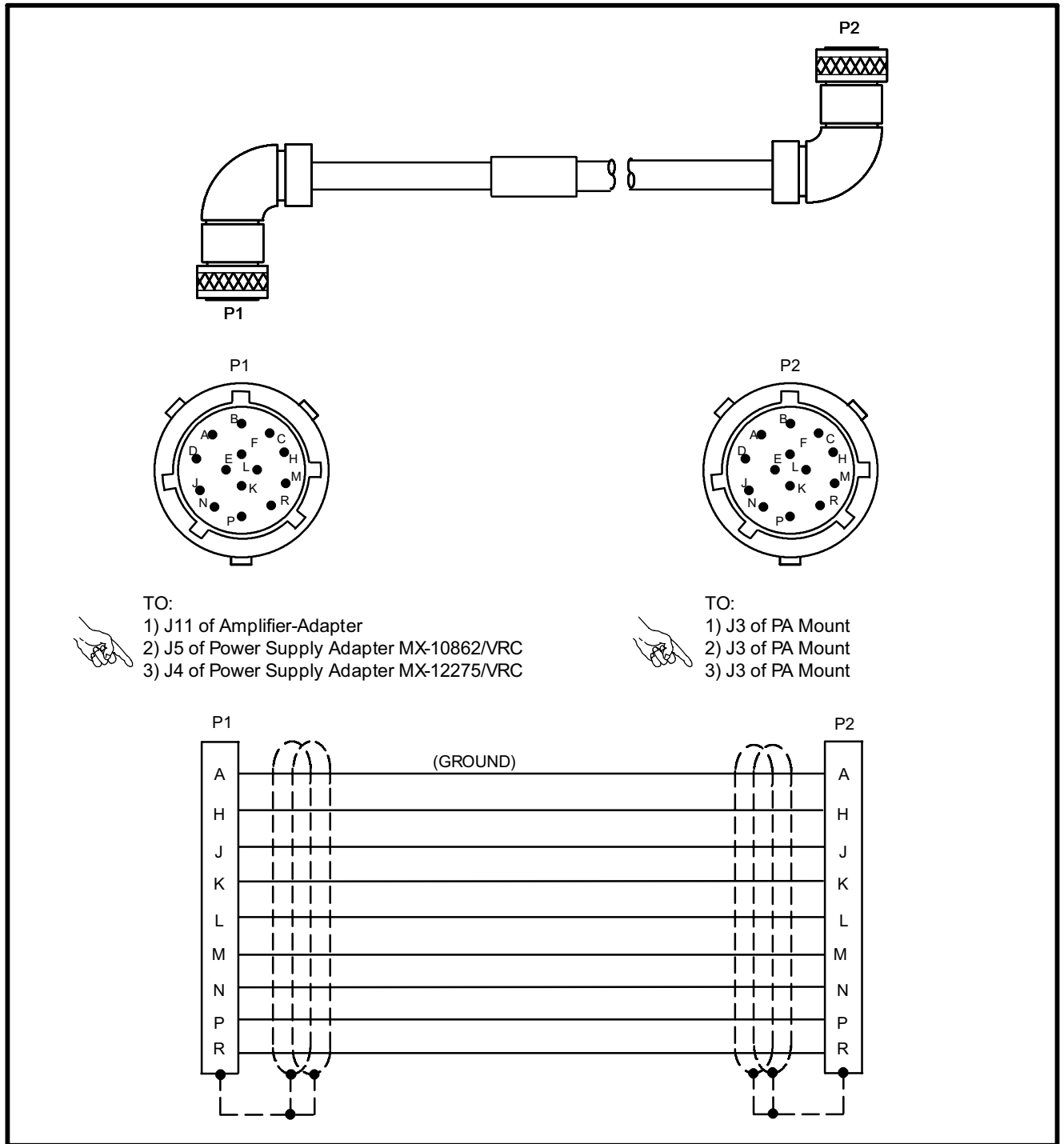

**CX-13291 (PA Control Cable)**

NOTE: ● filled-in indicates male connector  
○ not filled-in indicates female connector

4.2. SCHEMATICS. Continued

e. CX-13292 (LS-671 Cable)

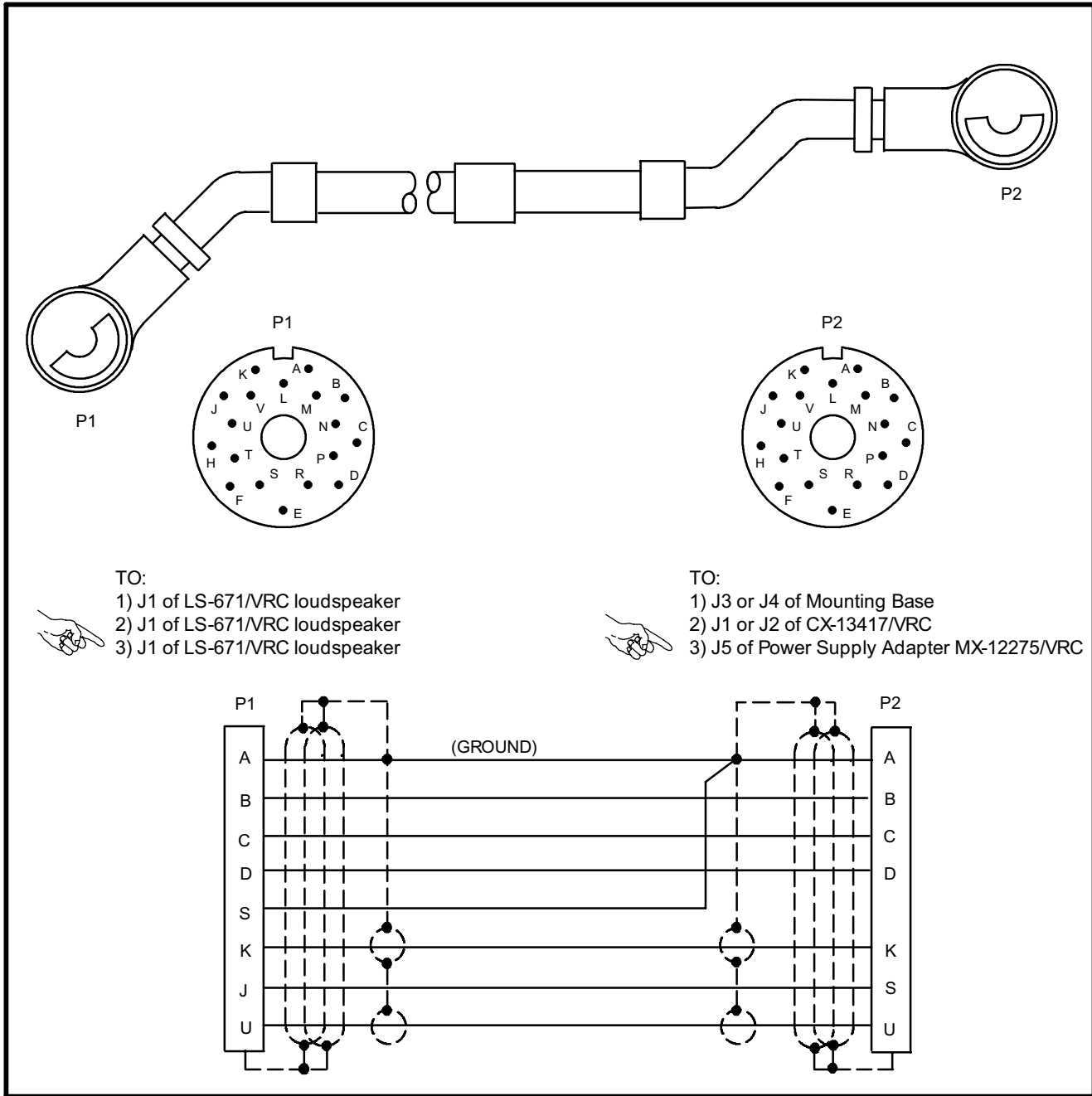

CX-13292 (LS-671 Cable) (W2)

4.2. SCHEMATICS. Continued

f. CX-13298 (RXMT Cable)

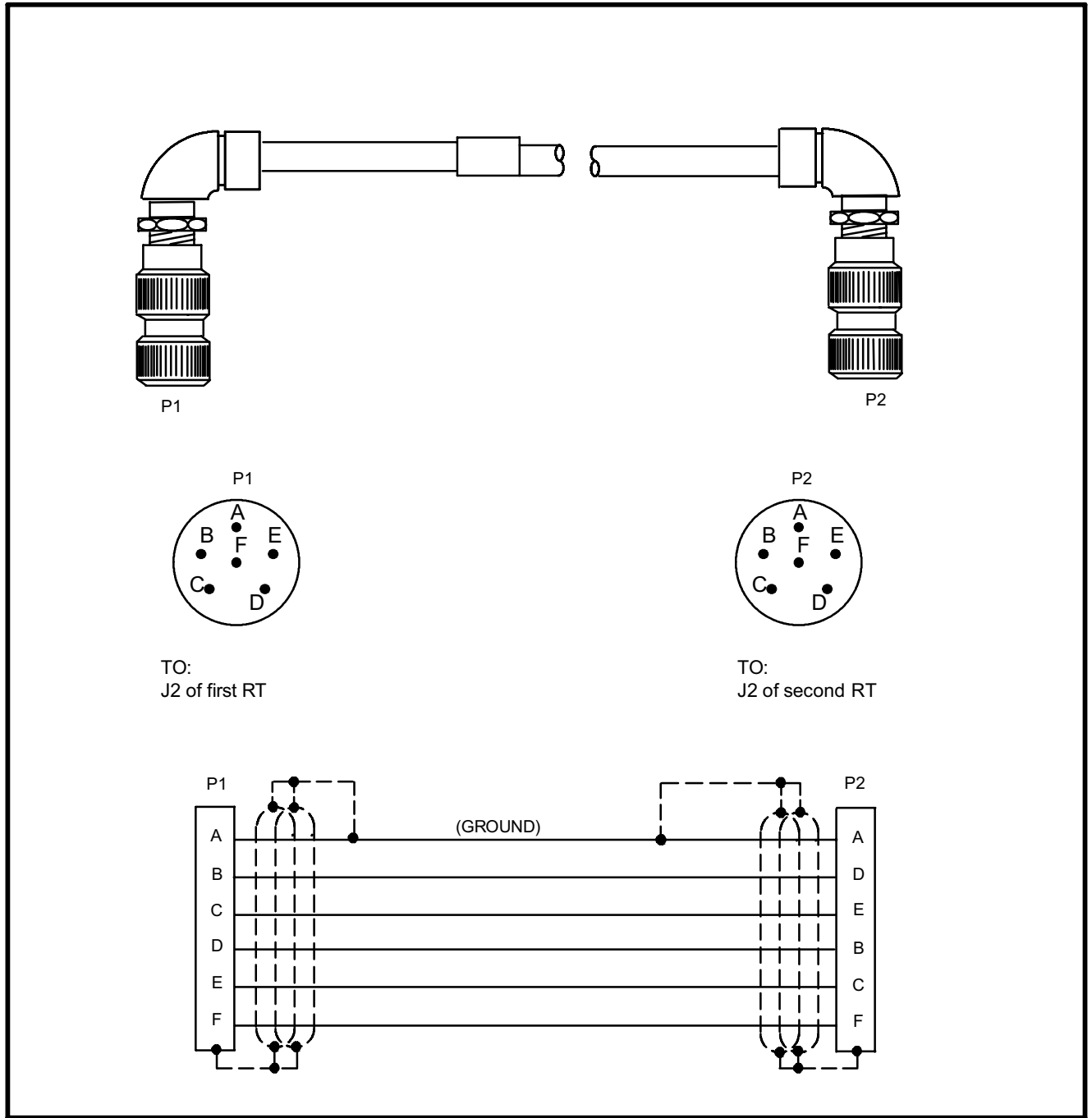

CX-13298 (RXMT Cable)

4.2. SCHEMATICS. Continued

g. CX-13300 (Intercom Cable)

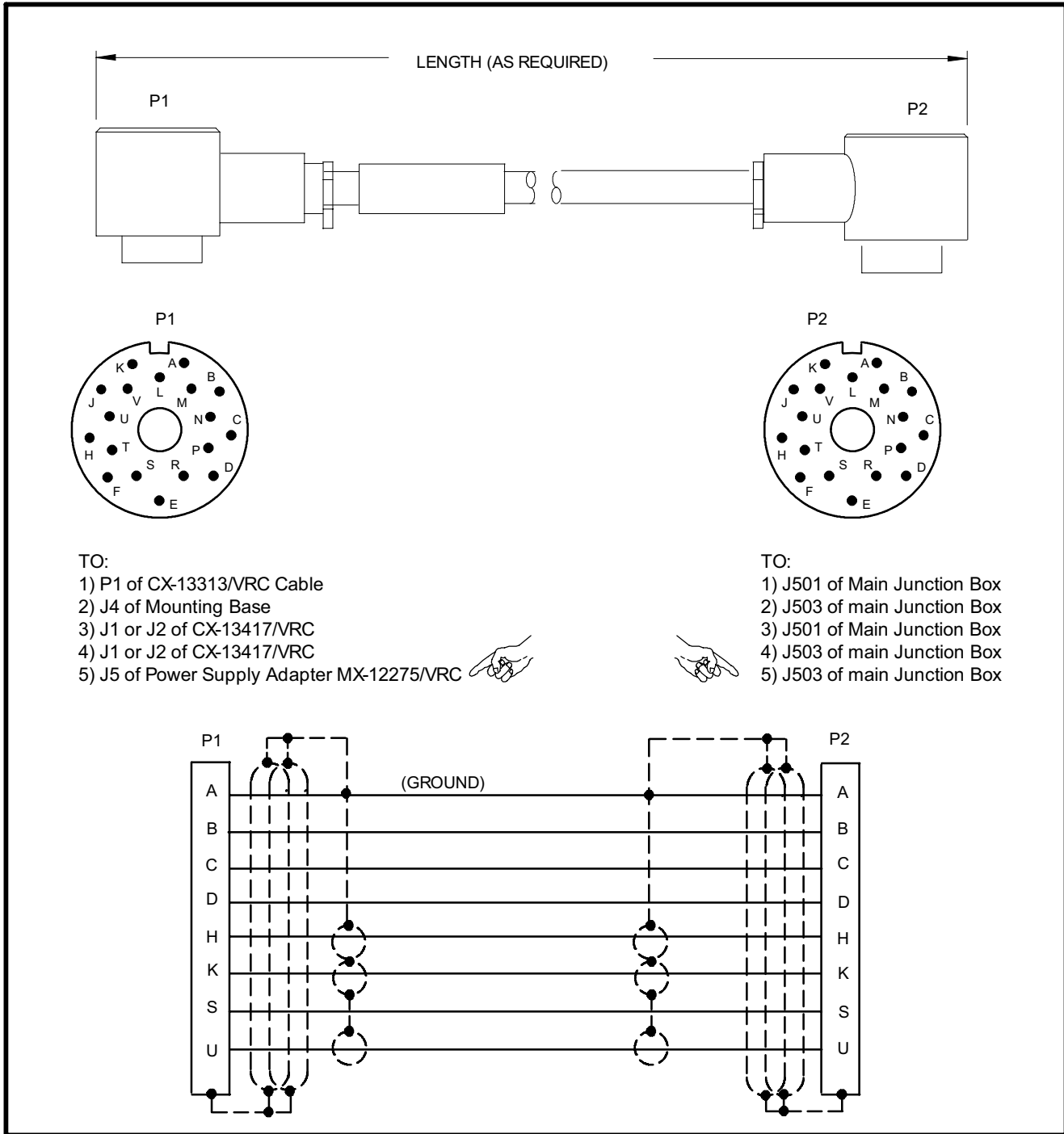

TO:

- 1) P1 of CX-13313/VRC Cable
- 2) J4 of Mounting Base
- 3) J1 or J2 of CX-13417/VRC
- 4) J1 or J2 of CX-13417/VRC
- 5) J5 of Power Supply Adapter MX-12275/VRC



TO:

- 1) J501 of Main Junction Box
- 2) J503 of main Junction Box
- 3) J501 of Main Junction Box
- 4) J503 of main Junction Box
- 5) J503 of main Junction Box



**CX-13300 (Intercom Cable)**

4.2. **SCHEMATICS.** Continued

h. **CX-13301 (M551 Power Cable)**

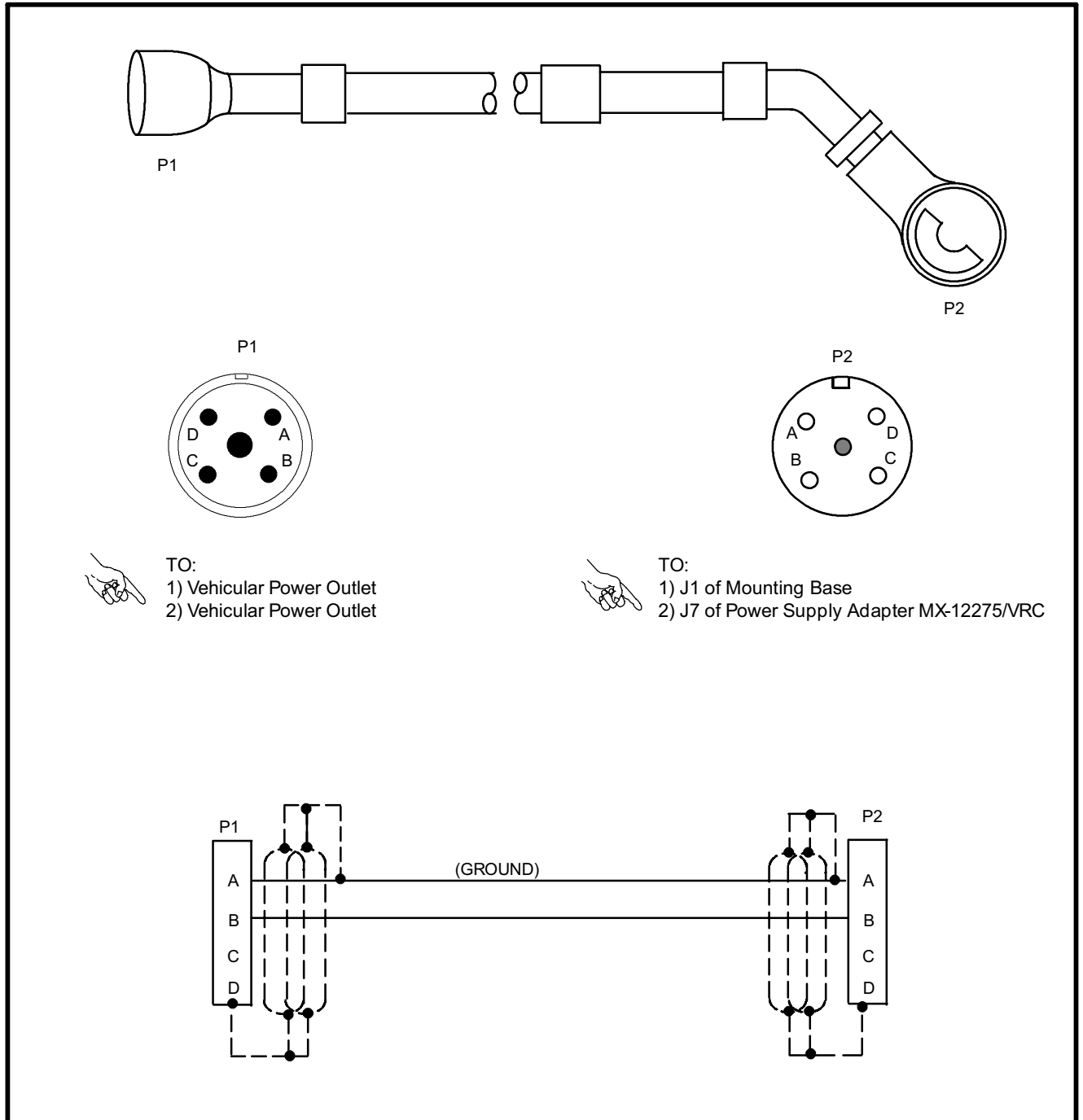

**CX-13301 (M551 Power Cable)**

4.2. SCHEMATICS. Continued

i. CX-13302 (Power Cable)

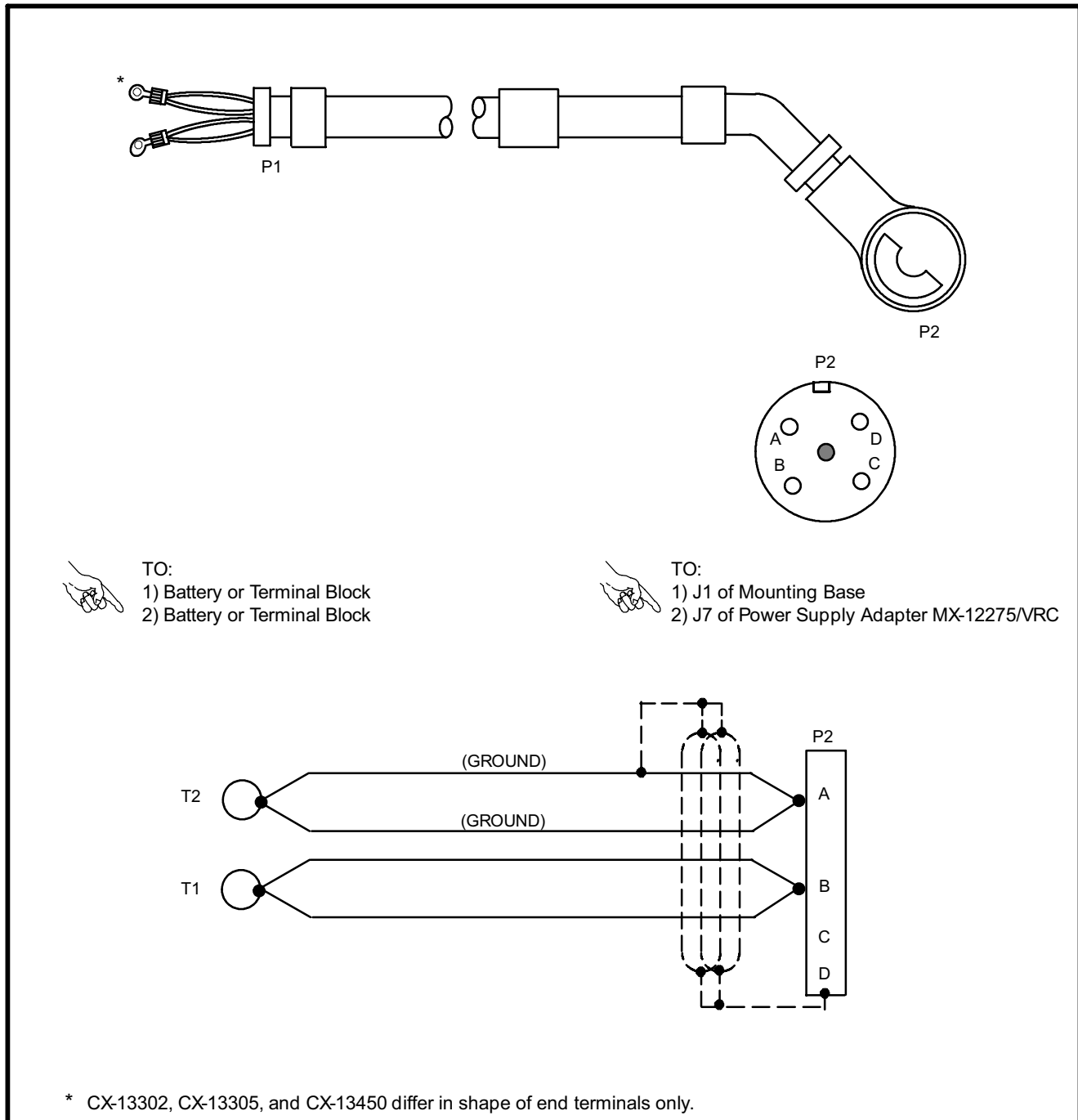

**CX-13302 (Power Cable)**

4.2. SCHEMATICS. Continued

j. CX-13303 (Power Cable)

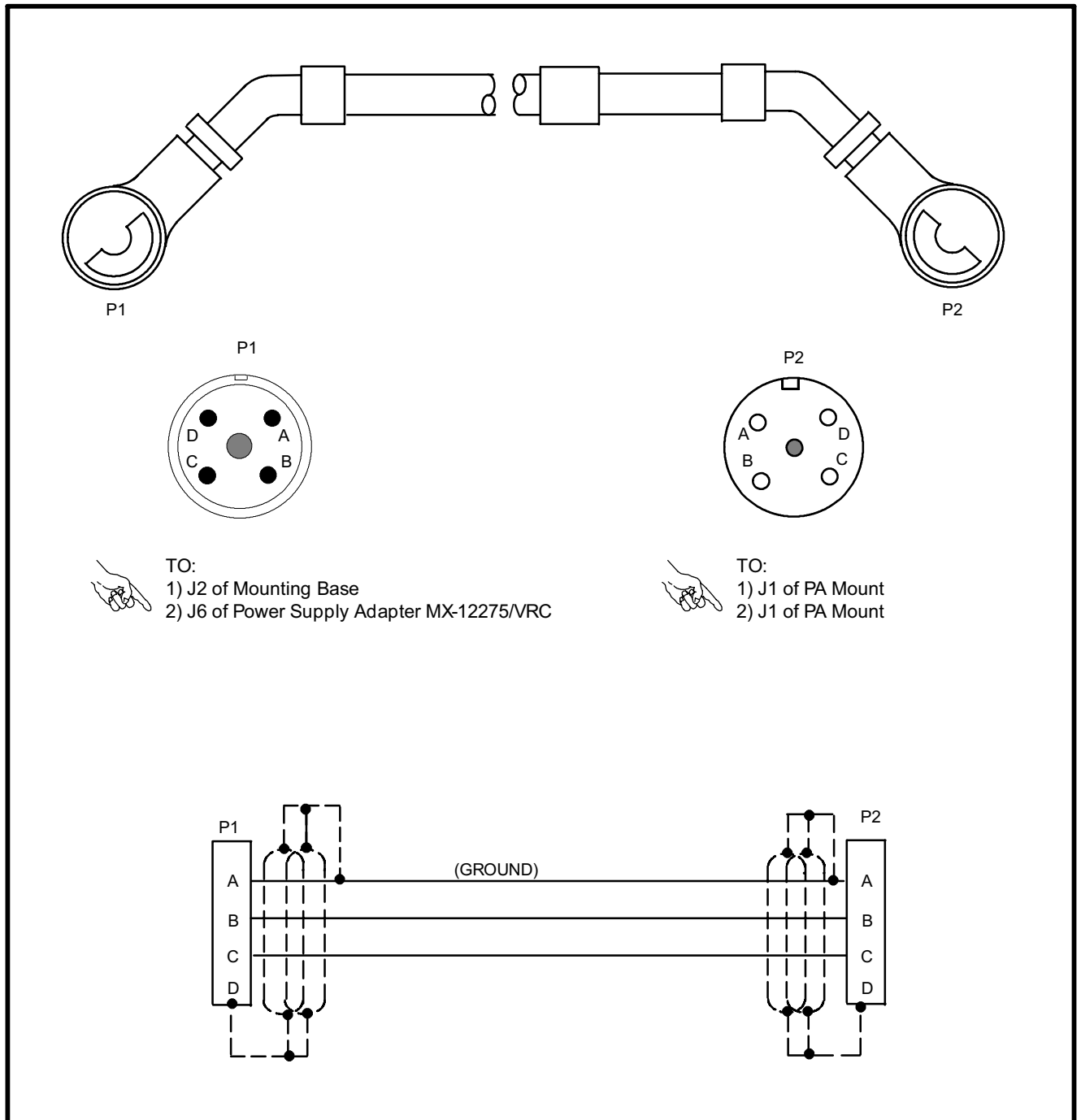

CX-13303 (Power Cable)

4.2. SCHEMATICS. Continued

k. CX-13304 (Power Cable)

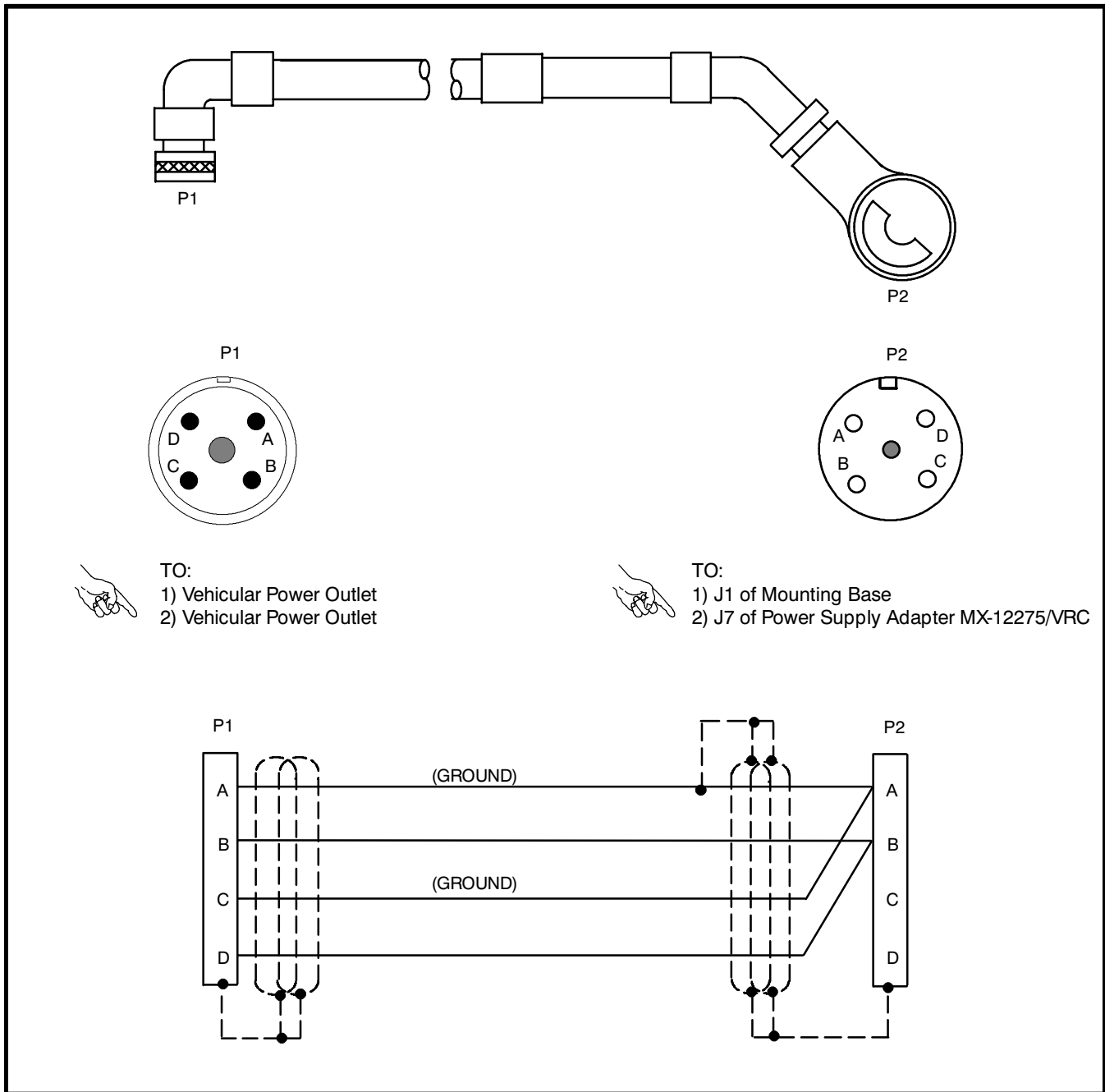

CX-13304 (Power Cable)



4.2. SCHEMATICS. Continued

I. CX-13305 (Power Cable)

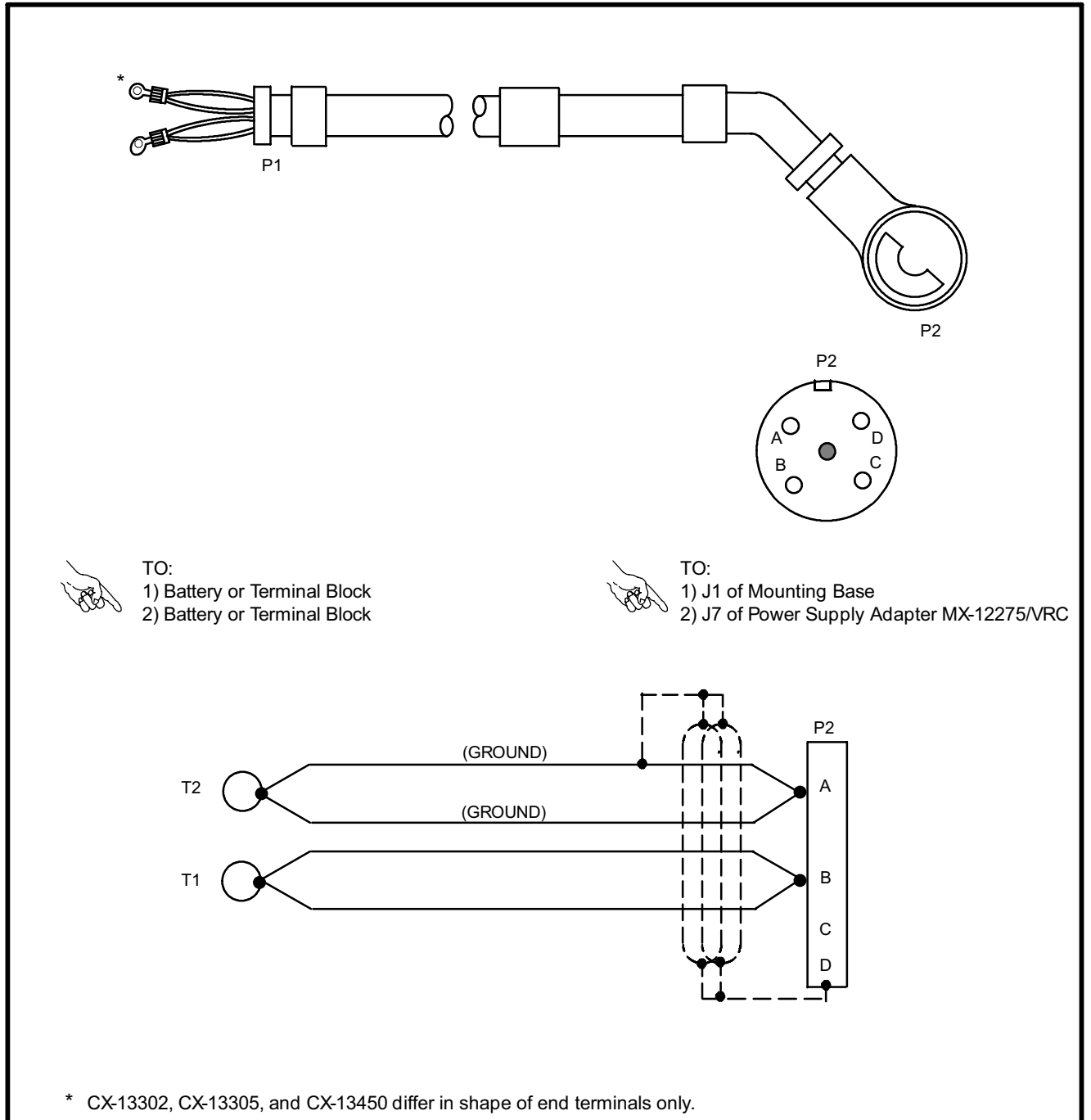

\* CX-13302, CX-13305, and CX-13450 differ in shape of end terminals only.

**CX-13305 (Power Cable)**

4.2. SCHEMATICS. Continued

m. CX-13306 (Power Cable)

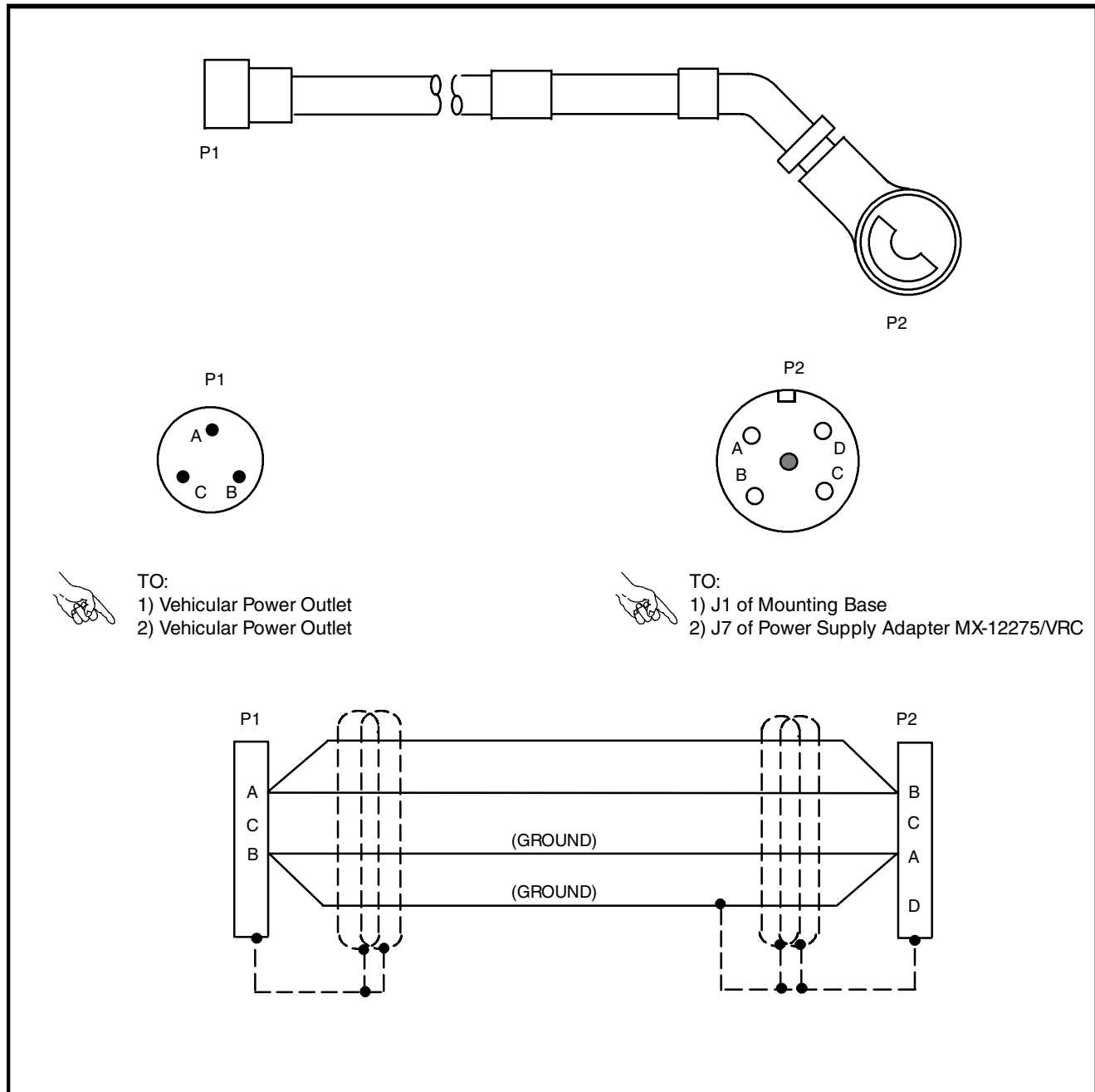

CX-13306 (Power Cable)

4.2. SCHEMATICS. Continued

n. CX-13308 (Data Cable)

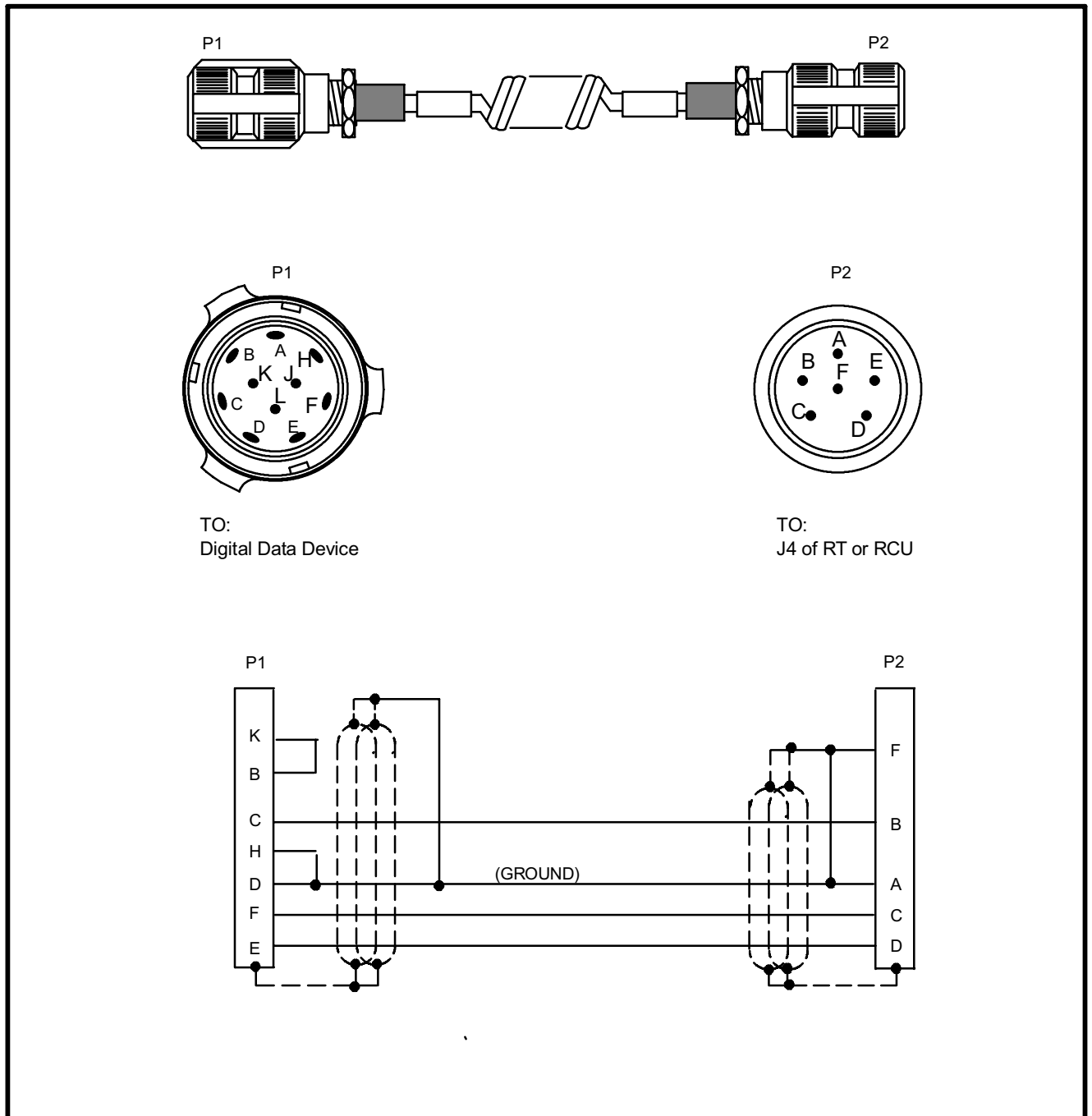

CX-13308 (Data Cable)

4.2. SCHEMATICS. Continued

o. CX-13310 (HYX-57 Cable)

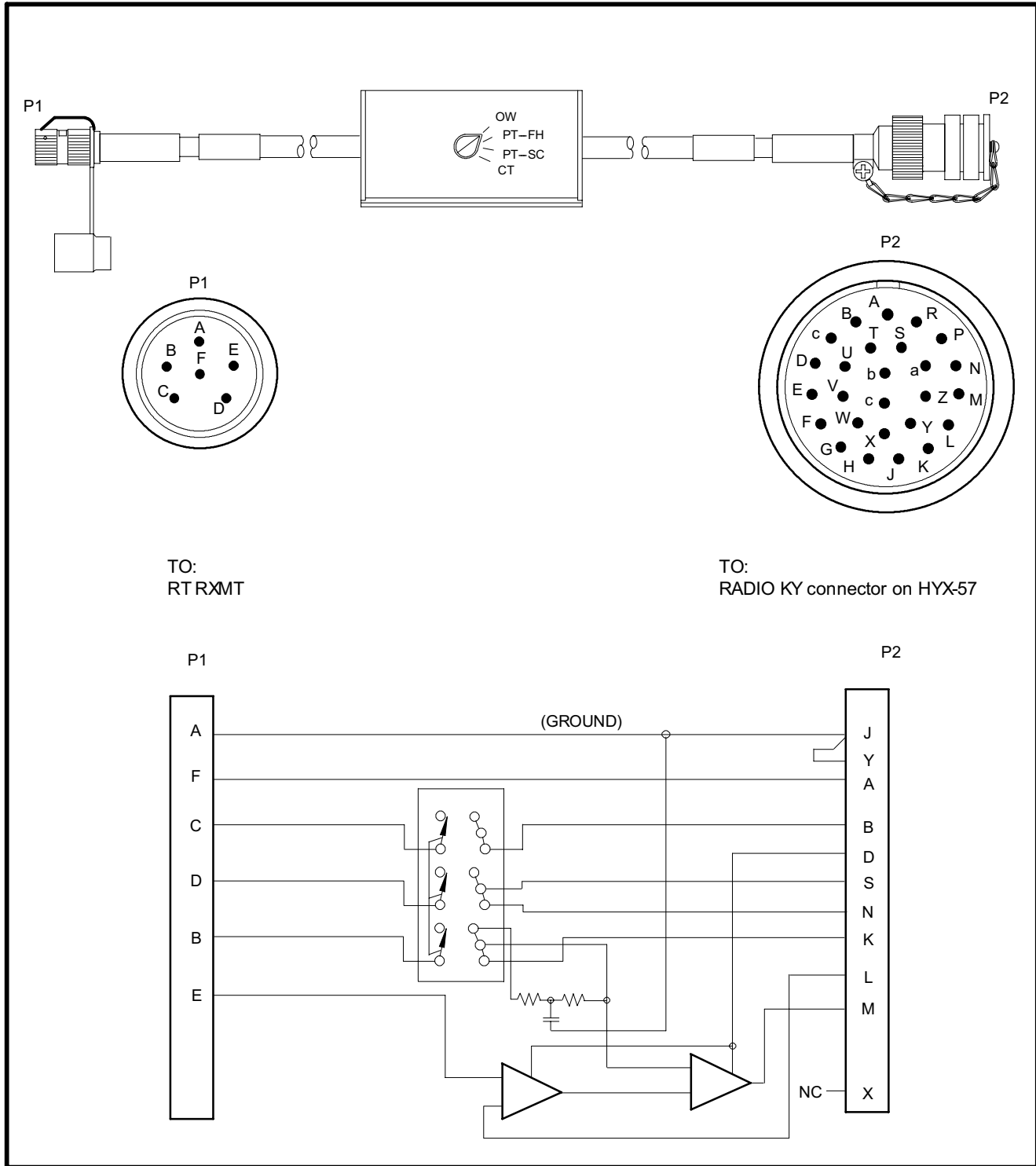

**CX-13310 (HYX-57 Cable)**

4.2. SCHEMATICS. Continued

p. CX-13311 (MST-20 Adapter Cable)

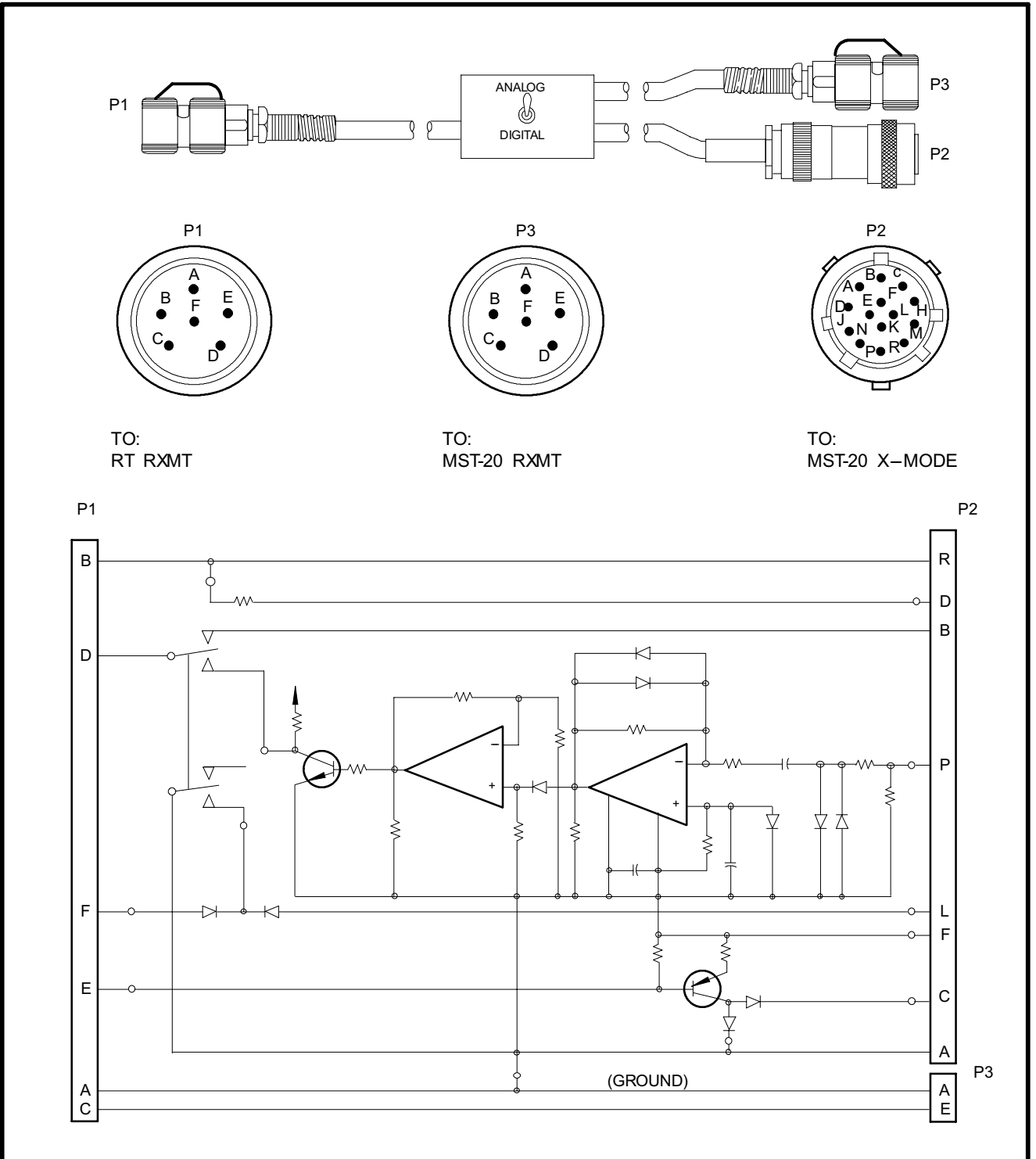

**CX-13311 (MST-20 Adapter Cable)**

4.2. SCHEMATICS. Continued

q. CX-13312 (PSC-3 Adapter Cable)

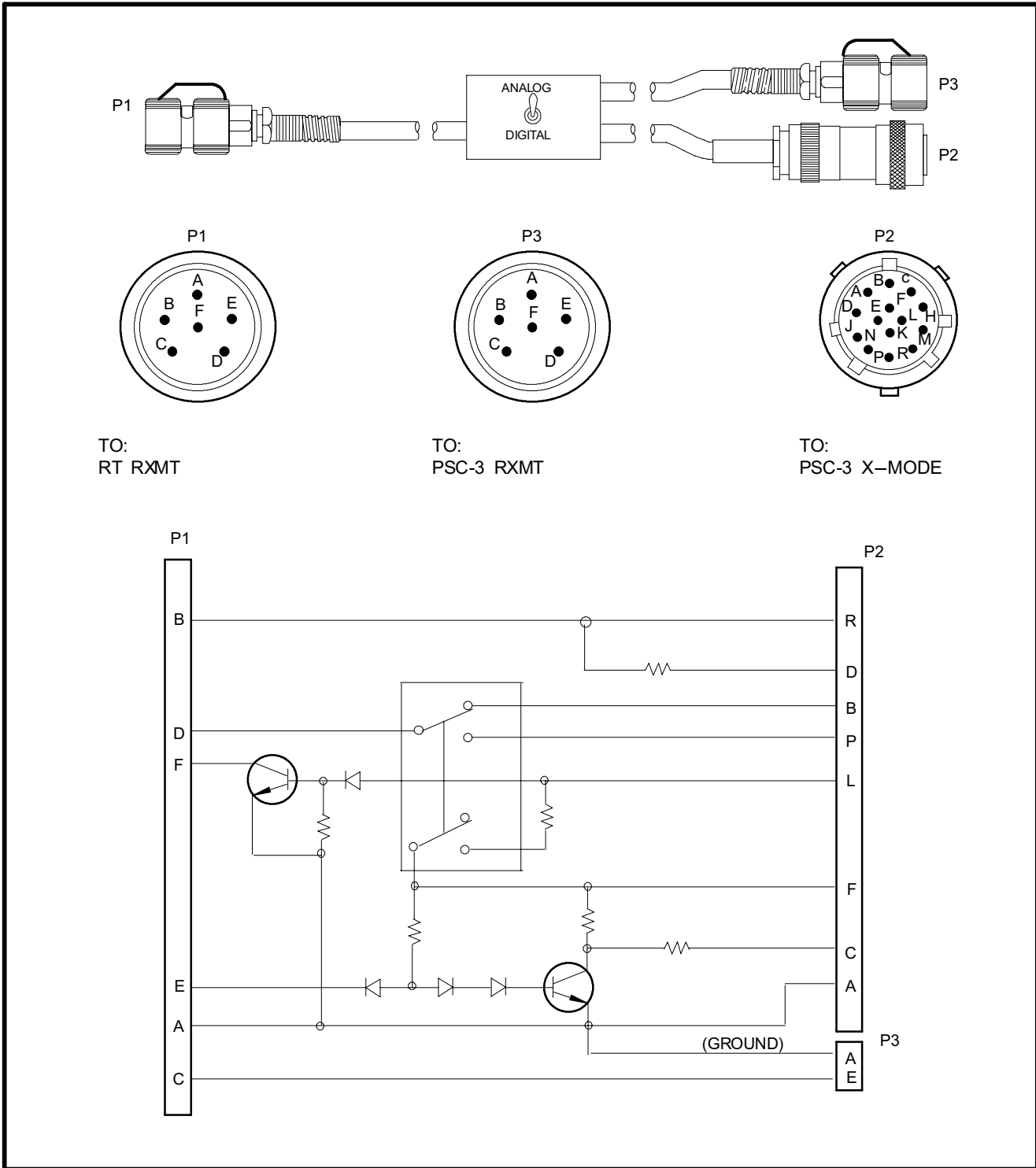

**CX-13312 (PSC-3 Adapter Cable)**

4.2. SCHEMATICS. Continued

r. CX-13313 (VIC Interface Cable)

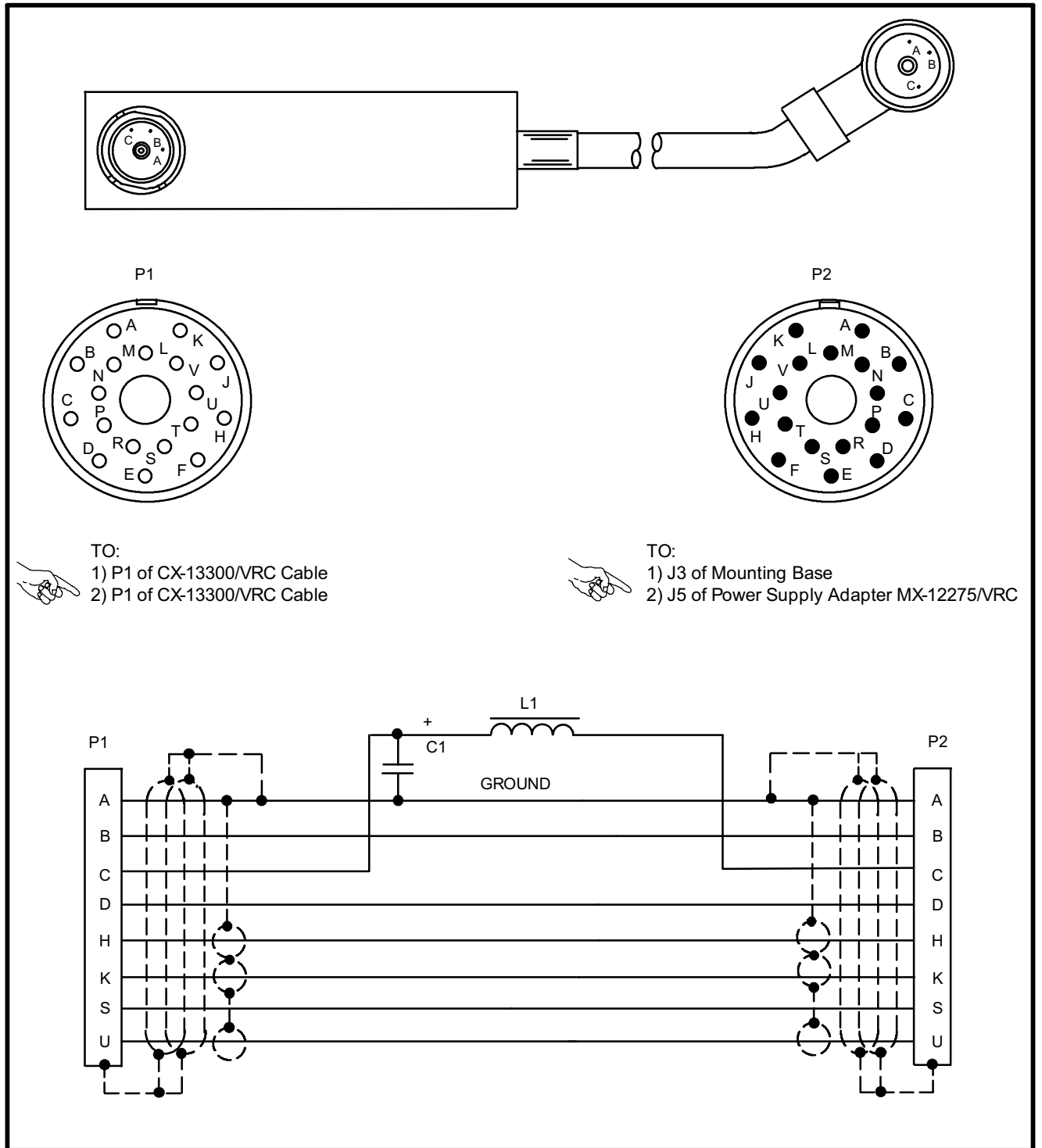

**CX-13313 (VIC Interface Cable)**

4.2. SCHEMATICS. Continued

s. CX-13402 (TACFIRE<sup>®</sup> Magic<sup>®</sup> Cable)

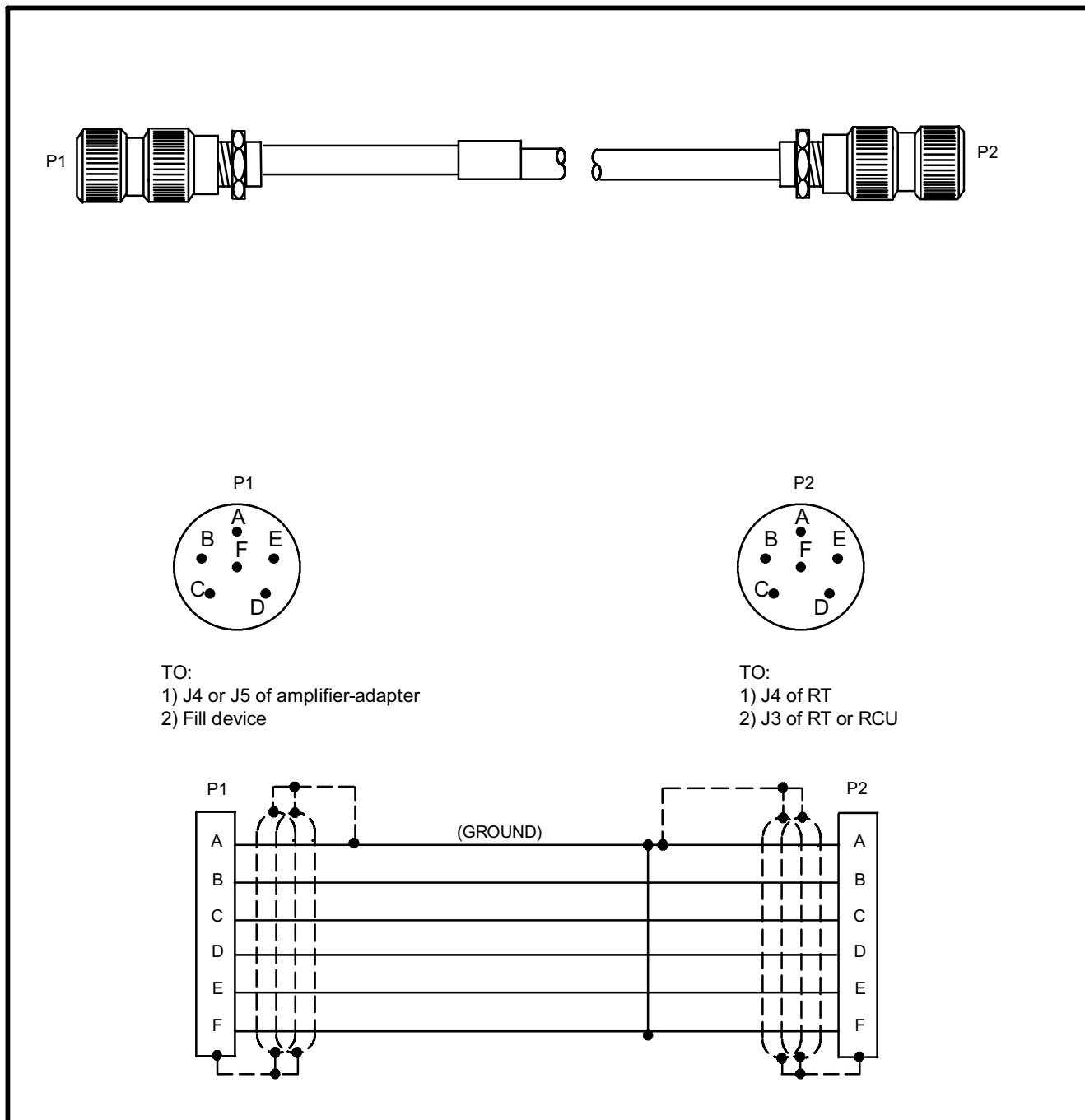

**CX-13402 (TACFIRE<sup>®</sup> Magic<sup>®</sup> Cable)**



4.2. SCHEMATICS. Continued

t. CX-13417 (Splitter Cable)

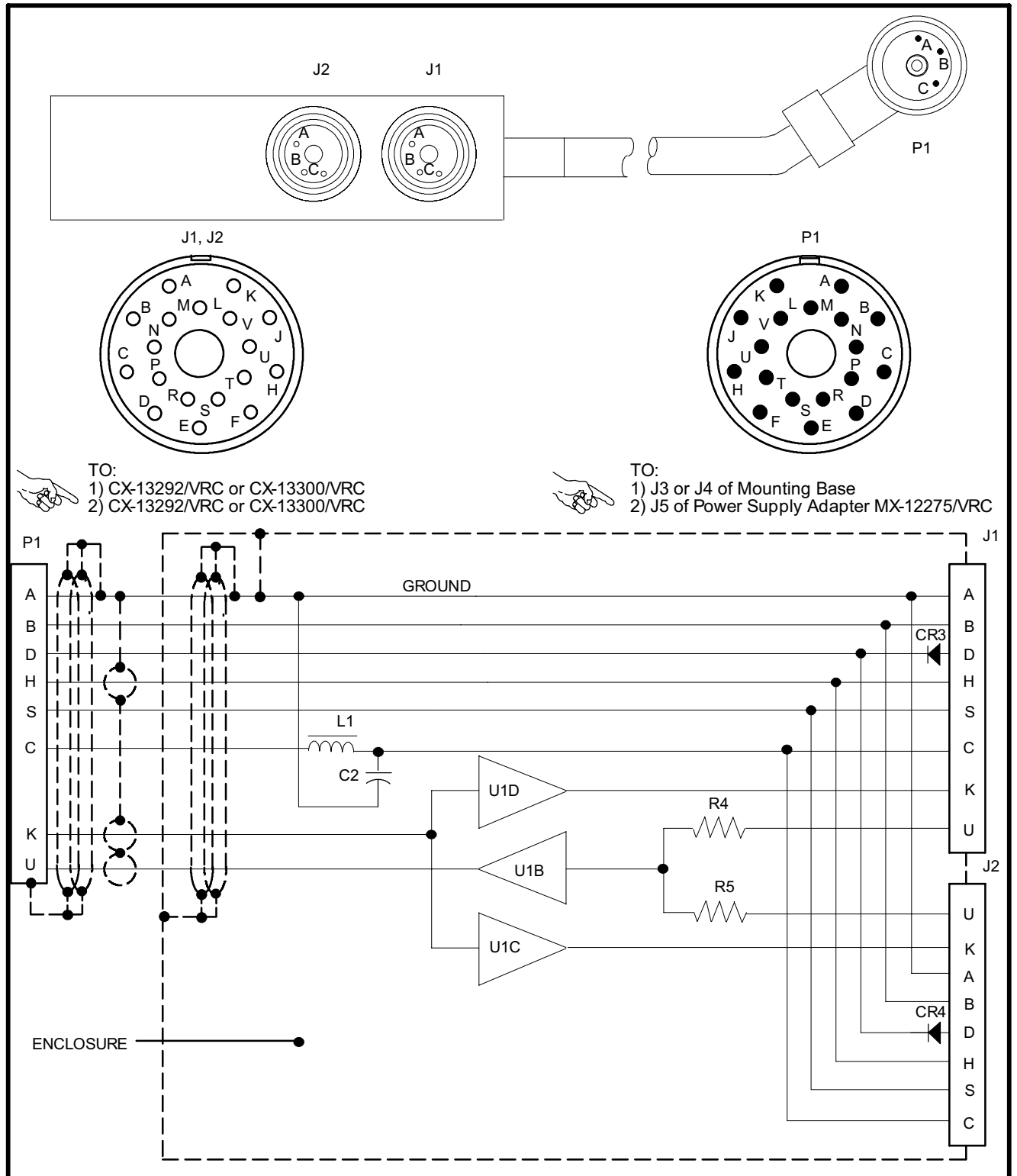

**CX-13417 (Splitter Cable)**

4.2. SCHEMATICS. Continued

u. CX-13450 (Power Cable)

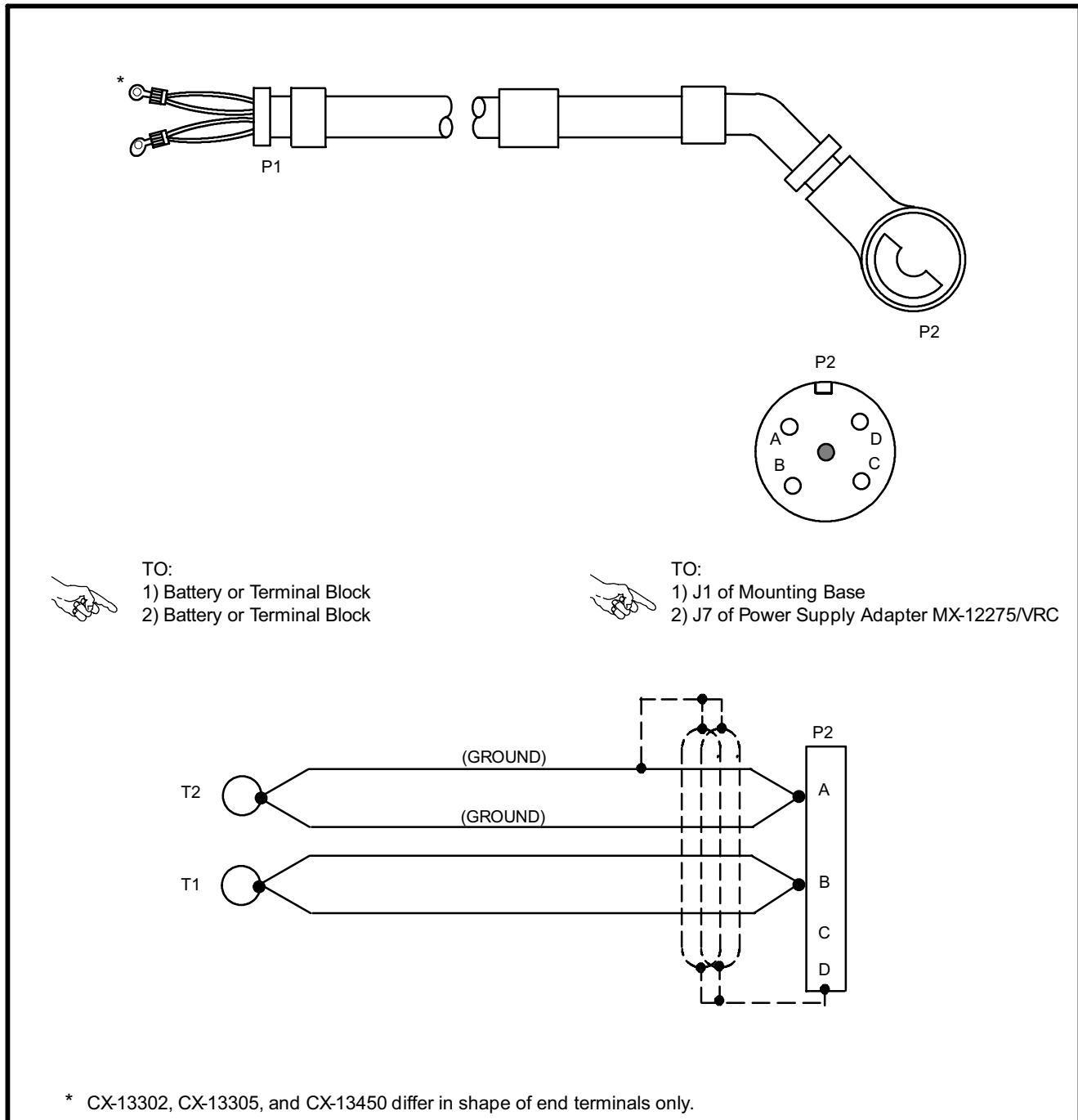

**CX-13450 (Power Cable)**

4.2. SCHEMATICS. Continued

v. CX-13465 (Digital Adapter Cable)

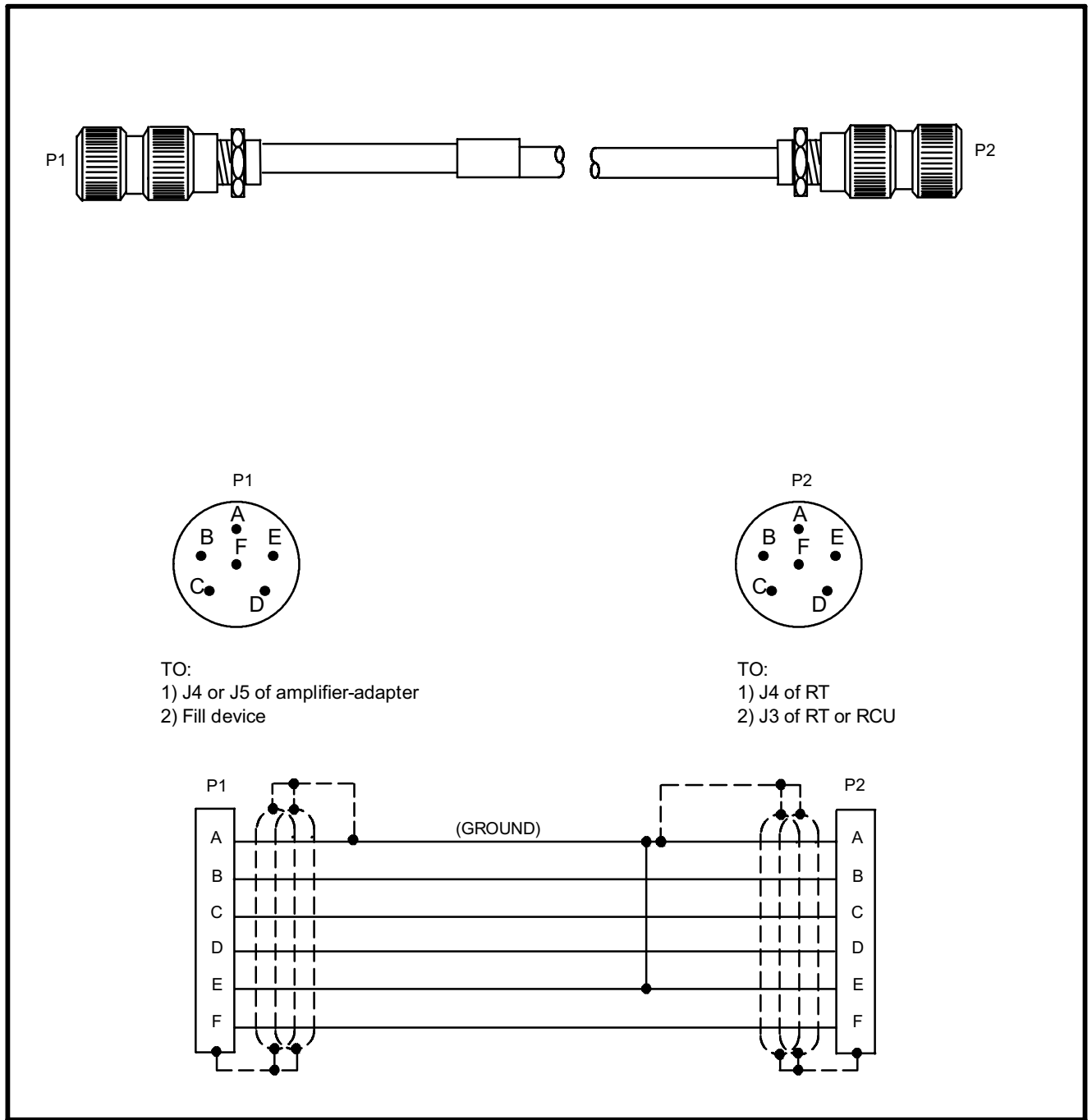

**CX-13465 (Digital Adapter Cable)**

4.2. SCHEMATICS. Continued

w. W4 (Audio/Data Fill Cable)

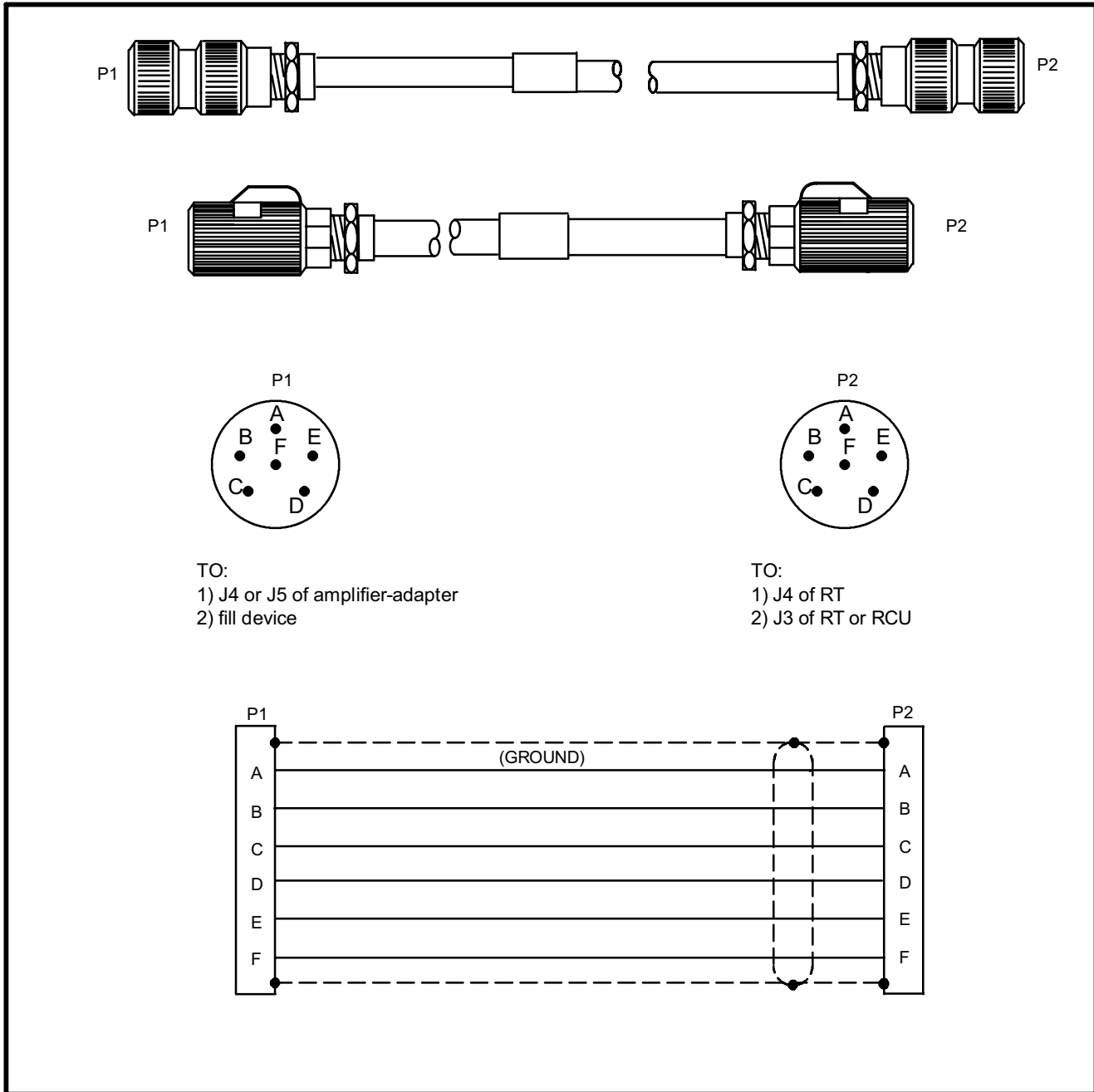

W4 (Audio/Data Fill Cable)

4.2. SCHEMATICS. Continued

x. W20 (GPS Fill Cable)

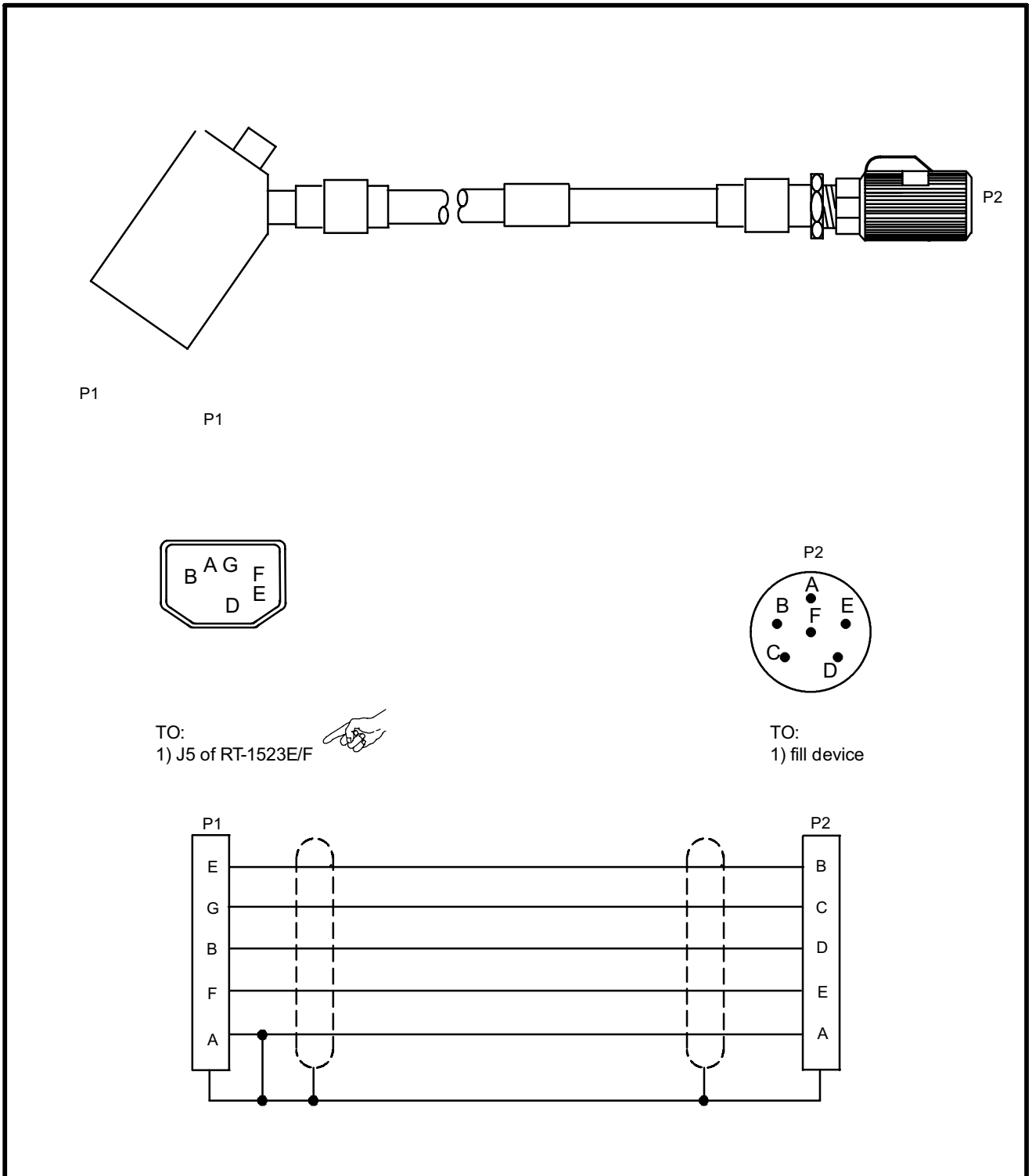

W20 (GPS Fill Cable)

4.2. SCHEMATICS. Continued

y. A3306914-1 (CDU Vehicular Adapter Cable)

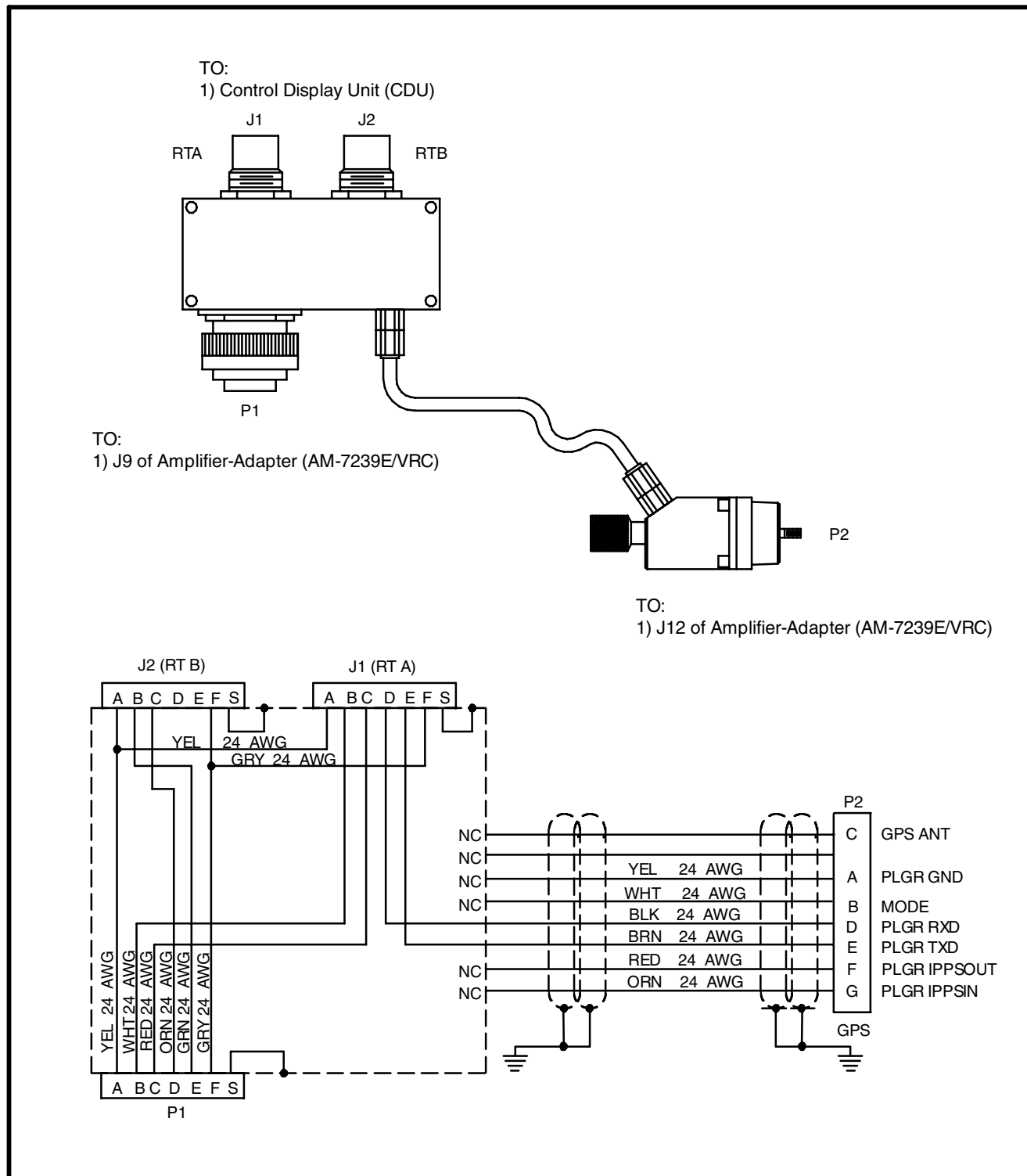

**A3306914-1 (CDU Vehicular Adapter Cable)**

## CHAPTER 5

### COMPONENT REPLACEMENT/REPAIR

Subject	Para	Page
Inspection Procedures .....	5.1	5-1
Component Replacement .....	5.2	5-4
Component Repair .....	5.3	5-13

#### 5.1. INSPECTION PROCEDURES.

The following chart shows, by radio system component, those items which should be inspected as a normal step in the maintenance process. Inspection consists of making those checks shown in the right column plus such other checks as the unit maintainer deems appropriate. Subsequent paragraphs provide guidance concerning replacement and repair of components. It should be noted that inspection requirements are in addition to checks made through application of the Operational Check and related use of Troubleshooting Flowcharts.

COMPONENT	ITEM	CHECK FOR:
a. RT	Case	Cracked or dented? Screws missing
	Displays	Cracked? Discolored? Damaged?
	Controls	Knobs missing? Set screws missing? Knobs tightly mounted on shaft?
	Connectors	Threads damaged or stripped? Cracks or bad chips between contacts?
	Connector caps	Protective caps broken or missing? Chains or cords broken or missing?
	Display cover (RT-1523E/F)	Display cover broken or missing?
b. Handset	N/A	Cracks in body? Cable torn or damaged? Connector broken? O-ring lubricated? Chips in pins? Packing nut tight?
	Knob (HRCRD)	Damaged or missing?
c. Control Display Unit	N/A	Cracks in body? Display cracked, discolored, or damaged? Cable torn or damaged? Connector broken? O-ring lubricated? Chips in pins? Packing nut tight?

5.1. INSPECTION PROCEDURES. Continued

COMPONENT	ITEM	CHECK FOR:
d. Manpack Antenna	Base	Damaged or broken?
	Blades or Rods	Bent or damaged? Retaining cords serviceable? Antenna fully extendable?
	Connectors	Threads damaged or stripped? Good connection achieved?
e. Vehicular Antenna	Element	Complete? Broken? Threads clean and lubricated?
	Base	O-ring distorted? Clean and lubricated?
	Safety wire	In place? Correctly installed?
	Mounting bracket	Complete? Broken?
	Ground	Correctly installed? Corroded or rusted? Good bond?
	Cables	Complete? Correctly routed? Pins bent or missing? Cover worn or torn? Connectors damaged?
f. VAA	Case	Cracked or dented? Hardware missing?
	Connectors	Threads damaged or stripped? Cracks or bad chips between contacts?
	Connector caps	Protective caps broken or missing? Chains or cords broken or missing?
	DS1	Tight connection to chassis? Lens damaged or missing?
	Thumbscrews	Thumbscrews serviceable?
	Seal screws	Seal screws damaged or missing?
g. MX-12275 Power Supply Adapter	Case	Cracked or dented? Hardware missing?
	Connectors	Threads damaged or stripped? Cracks or chips between contacts?
	Protective caps	Protective caps broken or missing?
	Thumbscrew	Thumbscrew serviceable?



5.1. INSPECTION PROCEDURES. Continued

COMPONENT	ITEM	CHECK FOR:
h. Power Amplifier	Case	Cracked or dented?
	Connectors	Threads damaged or stripped? Cracks or bad chips between contacts? Keyways damaged? Bent or broken contacts?
i. Mounting Base	Frame	Cracked or dented? Hardware missing?
	Connectors	Threads damaged or stripped? Cracks or bad chips between contacts?
	Connector caps	Protective caps broken or missing? Chains or cords broken or missing?
	Thumbscrews	Thumbscrews serviceable?
	Seal screw	Seal screws damaged or missing?
j. Battery Box	Case	Cracked or dented?
	Connectors	Threads damaged or stripped? Cracks or bad chips between contacts?
	Strike catches	Screws loose or missing? Catches damaged?
	Gasket	Cut or torn? Properly seated?
k. Loudspeaker	Case	Cracked or dented?
	Connectors	Threads damaged or stripped? Cracks or bad chips between contacts?
	DS1	Tight connection to chassis? Lens damaged or missing?
l. Two-Wire Adapter	Case	Cracked or dented?
	Connectors	Threads damaged or stripped? Cracks or bad chips between contacts?

## 5.2. COMPONENT REPLACEMENT.

The following charts show by radio system component, those actions required to remove and install each component. These charts cover all components of a long range, dual radio system (AN/VRC-92A/D/F) and long range, single ASIP radio mount system (AN/VRC-90G). Skip any component that is not a part of the system being worked on. The component that needs to be replaced will be identified by inspection, as noted above, or through application of the Operational Check and related Troubleshooting Flowcharts. A general rule is to remove only those components that are required for maintenance.

### WARNING

**REMOVE vehicular power from Mounting Base connector J1 or from Power Supply Adapter MX-12275 connector J7 before removing or replacing components. If vehicular power is not removed, some connectors will have 22 to 32 V dc present.**

**In replacing an LS-671 Loudspeaker, disconnect cable from Mounting Base connector J3 or J4 or from Power Supply Adapter MX-12275 connector J5. If cable is not disconnected, there will be 22 to 32 V dc present at pin B of the open cable connector.**

### CAUTION

**DO NOT** under any circumstances remove component covers or remove modules from components. Opening components in the field will destroy them.

**DO NOT** tilt or twist the RT when removing it from, or replacing it in, a vehicular amplifier adapter (VAA) or a power supply adapter (PSA) MX-12275 to avoid damaging the connectors. The RT must be flat on the VAA or PSA MX-12275 when mating the connectors.

**a. Receiver-Transmitter (RT):**

TO REMOVE:	TO REPLACE:
(1) Set VAA or PSA MX-12275 CB1 to OFF; if used, set LS-671 CB1 to OFF	(1) Position RT in VAA or PSA MX-12275
(2) Remove locking bar	(2) Tighten VAA thumbscrews or PSA MX-12275 thumbscrew to secure RT
(3) If used, disconnect W4 from RT	(3) If used, connect W4 to RT
(4) If used, disconnect handset from RT	(4) If used, connect handset to RT
(5) Disconnect RF cable from RT ANT J1	(5) Connect RF cable to RT ANT J1
(6) Loosen VAA thumbscrews or PSA MX-12275 thumbscrew securing RT	(6) Replace locking bar
(7) Pull RT straight forward to clear VAA or PSA MX-12275	(7) Set VAA or PSA MX-12275 CB1 to ON; if used, set LS-671 CB1 to ON

5.2. COMPONENT REPLACEMENT. Continued

**NOTE**

Remove holding battery before evacuating bad RT to Direct Support. The battery is removed to avoid compromise of any loaded variables.

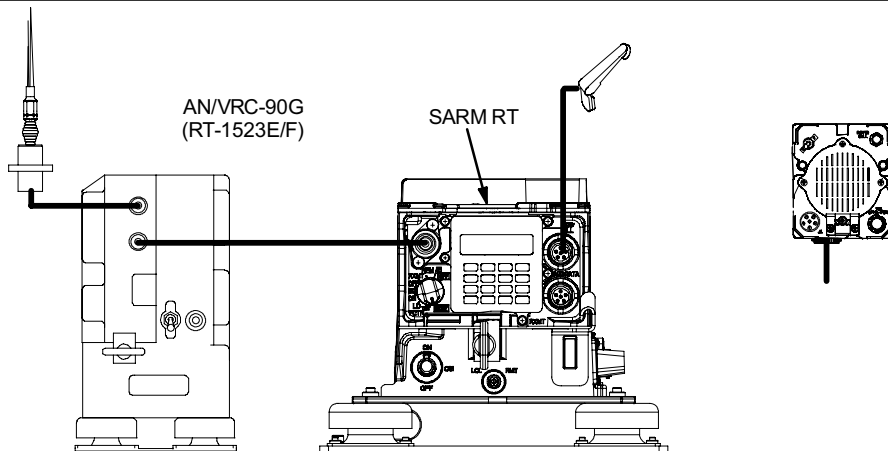
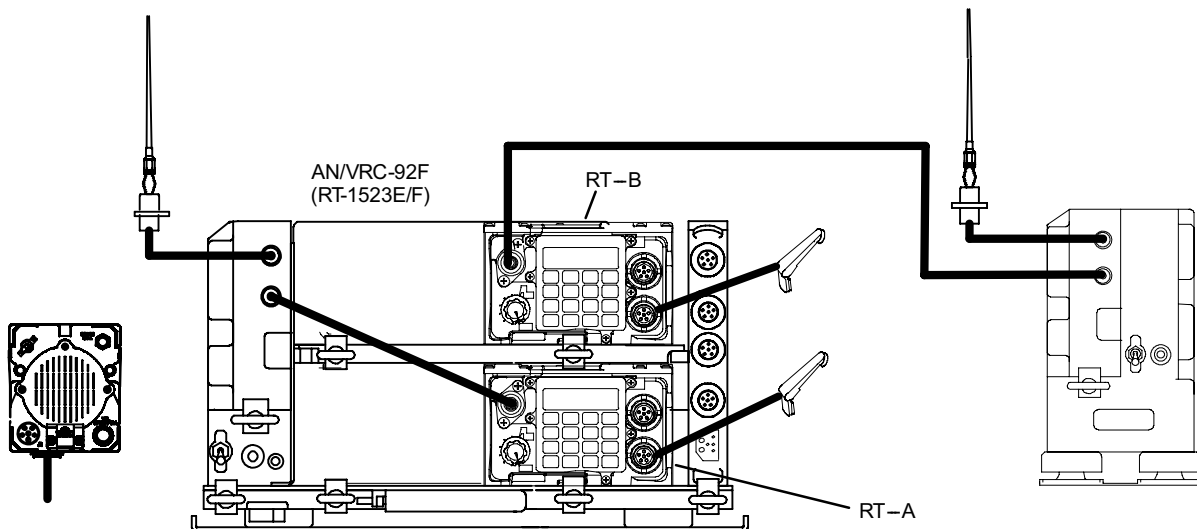
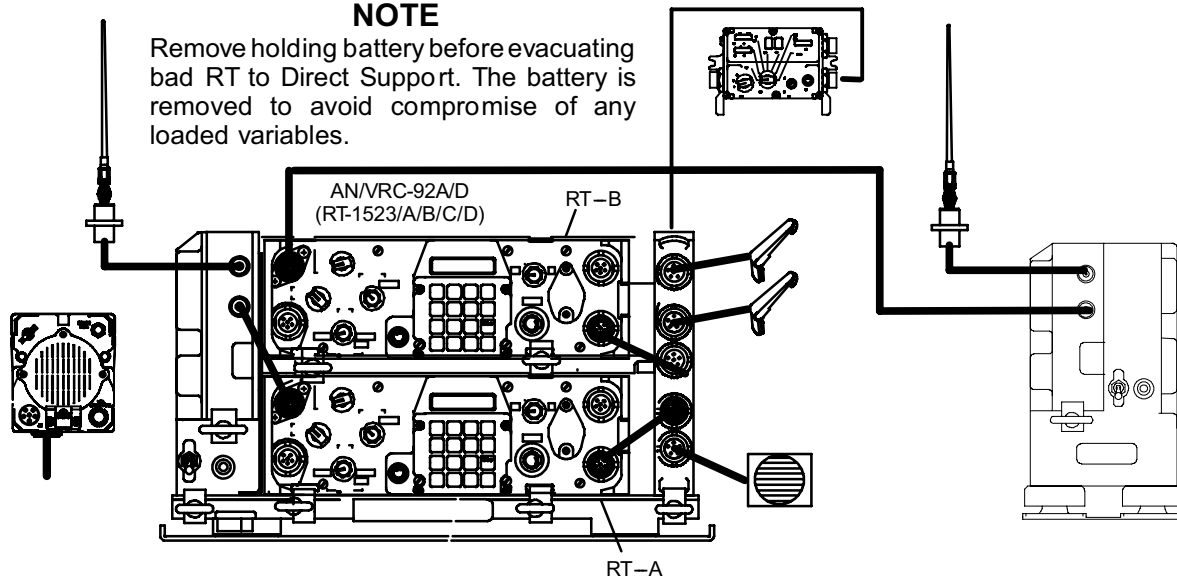

**5.2. COMPONENT REPLACEMENT.** Continued

**b. RT-A Power Amplifier (PA):**

<b>TO REMOVE:</b>	<b>TO REPLACE:</b>
(1) Set VAA CB1 to OFF; if used, set LS-671 CB1 to OFF	(1) Position PA in VAA
(2) Remove locking bar	(2) Tighten VAA thumbscrew to secure PA
(3) Disconnect RF cable from PA J2	(3) Connect antenna cable to PA J1
(4) Disconnect antenna cable from PA J1	(4) connect RF cable to PA J2
(5) Loosen VAA thumbscrew securing PA	(5) Replace locking bar
(6) Pull RT-A PA straight forward to clear VAA	(6) Set VAA CB1 to ON; if used, set LS-671 CB1 to ON

**c. Vehicular Amplifier-Adapter (VAA):**

<b>TO REMOVE:</b>	<b>TO REPLACE:</b>
(1) Set VAA CB1 to OFF; if used, set LS-671 CB1 to OFF	(1) Place VAA in either LOCAL or REMOTE (refer to paragraph 5.3.b.)
(2) Remove RT-A and RT-B (refer to paragraph 5.2.a.)	(2) Position VAA on MB, slide into correct place
(3) Remove RT-A PA (refer to paragraph 5.2.NO TAG)	(3) Push lever into locked position
(4) If used, disconnect C-M cable from VAA J9	(4) Tighten MB thumbscrews to secure VAA
(5) If used, disconnect handsets from VAA	(5) If used, connect RCU wires to VAA posts E1 A&B/E2 A&B
(6) If used, disconnect CDU vehicular adapter cable from VAA (AM-7239E only) J9	(6) If used, connect CDU vehicular adapter cable to VAA J9
(7) If used, disconnect W4s from VAA	(7) If used, connect C-M cable to VAA J9
(8) If used, disconnect LS-454 cable from VAA J6	(8) If used, connect LS-454 cable to VAA J6
(9) If used, disconnect RT-B PA CX-13291 from VAA J11	(9) If used, connect RT-B PA CX-13291 to VAA J11
(10) If used, disconnect RCU wires from VAA E1 A&B/E2 A&B	(10) If used, connect W4s to VAA
(11) Loosen thumbscrews securing VAA to MB	(11) If used, connect handsets to VAA
(12) Pull lever forward until disengaged	(12) Replace RT-A PA (refer to paragraph 5.2.NO TAG)
(13) Pull VAA straight forward to clear MB	(13) Replace RT-A and RT-B (refer to paragraph 5.2.a.)
	(14) Set VAA CB1 to ON; if used, set LS-671 CB1 to ON

**5.2. COMPONENT REPLACEMENT.** Continued

**d. Mounting Base (MB):**

TO REMOVE:	TO REPLACE:
(1) Set VAA CB1 to OFF; if used, set LS-671 CB1 to OFF	(1) Place MB in position on shelf
(2) Remove RT-A and RT-B (refer to paragraph 5.2.a.)	(2) Replace bolts (5), IET lockwashers (6), and nuts (8) securing MB to shelf
(3) Remove RT-A PA (refer to paragraph 5.2.b.)	(3) Replace all cables on connectors
(4) Remove VAA (refer to paragraph 5.2.c.)	(4) Replace VAA (refer to paragraph 5.2.c.)
(5) Remove all cables from connectors	(5) Replace RT-A PA (refer to paragraph 5.2.b.)
(6) Remove bolts (5), IET lockwashers (6), and nuts (8) from MB	(6) Replace RT-A and RT-B (refer to paragraph 5.2.a.)
(7) Remove MB from shelf	(7) Set VAA CB1 to ON; if used, set LS-671 CB1 to ON

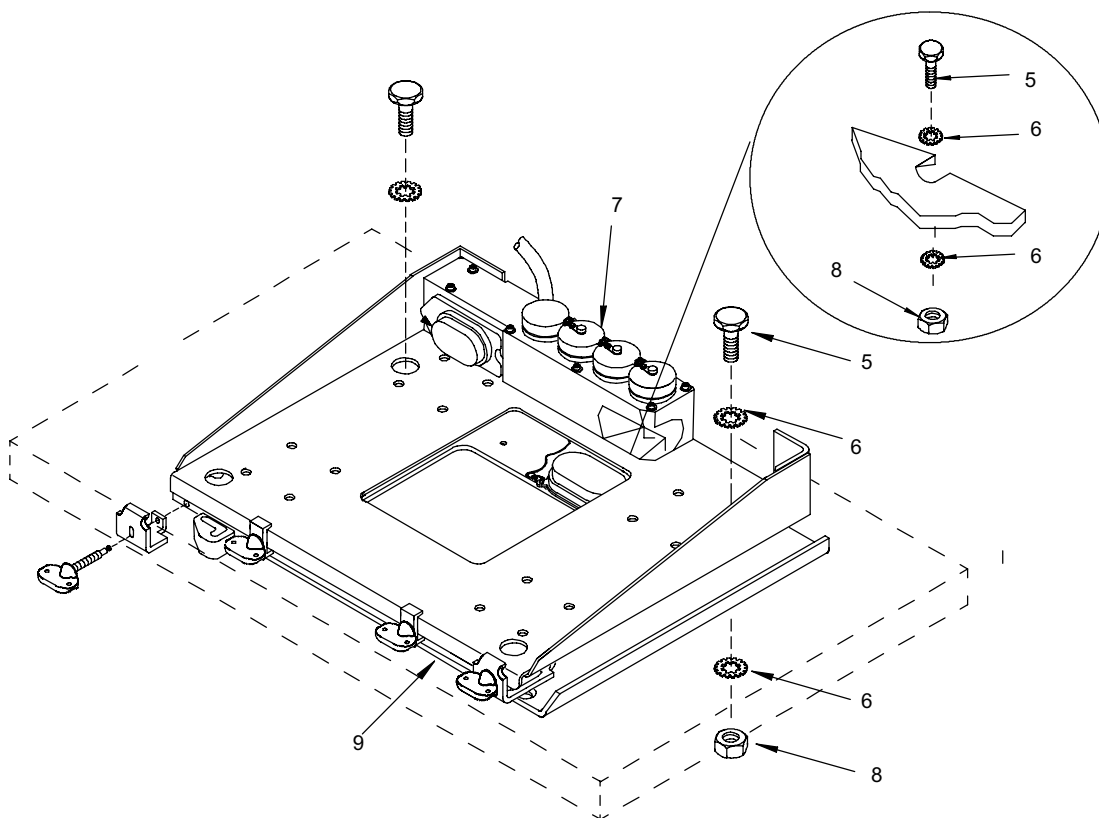

**5.2. COMPONENT REPLACEMENT.** Continued

**e. Power Supply Adapter (PSA) (MX-12275):**

TO REMOVE:	TO REPLACE:
(1) Set PSA MX-12275 CB1 to OFF; if used, set LS-671 CB1 to OFF	(1) Place PSA MX-12275 on shelf
(2) Remove SARM RT (refer to paragraph 5.2.a.)	(2) Replace bolts (1), IET lockwashers (2), and nuts (3) to PSA MX-12275
(3) If used, disconnect SARM RT PA CX-13291 from PSA MX-12275 J4	(3) Set PSA MX-12275 S1 to RMT (remote); if LS-671 or VIC present Set PSA MX-12275 S1 to LCL (local); if external equipment not used
(4) If used, disconnect SARM RT PA CX-13303 from PSA MX-12275 J6	(4) If used, connect SARM RT PA CX-13291 to PSA MX-12275 J4
(5) Remove bolts (1), IET lockwashers (2), and nuts (3) from PSA MX-12275	(5) If used, connect SARM RT PA CX-13303 to PSA MX-12275 J6
(6) Remove PSA MX-12275 from shelf	(6) Replace SARM RT (refer to paragraph 5.2.a.)
	(7) Set PSA MX-12275 CB1 to ON; if used, set LS-671 CB1 to ON

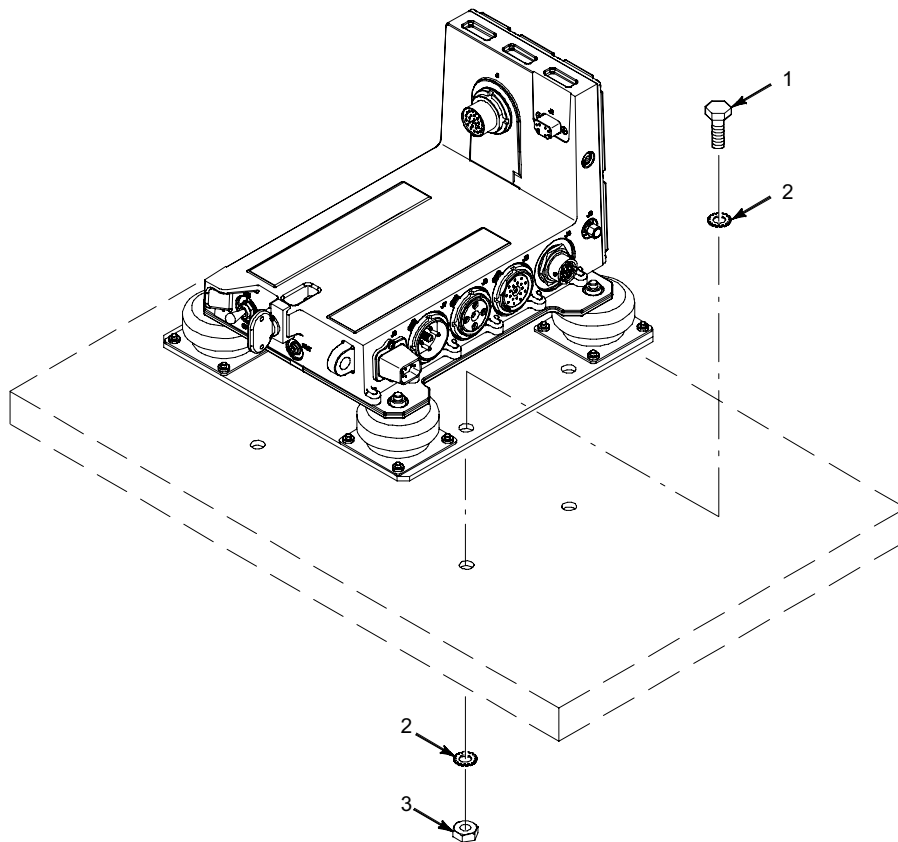

**5.2. COMPONENT REPLACEMENT.** Continued

**f. RT-B/SARM RT Power Amplifier (PA):**

<b>TO REMOVE:</b>	<b>TO REPLACE:</b>
(1) Set VAA or PSA MX-12275 CB1 to OFF; if used, set LS-671 CB1 to OFF	(1) Position RT-B/SARM RT PA in PA Mount
(2) Set RT-B/SARM RT PA Mount CB1 to OFF	(2) Tighten thumbscrew securing RT-B/SARM RT PA to PA Mount
(3) Remove RF cables from RT-B/SARM RT PA J1 and J2	(3) Connect RF cables to RT-B/SARM RT PA J1 and J2
(4) Loosen thumbscrew securing RT-B/SARM RT PA to PA Mount	(4) Set RT-B/SARM RT PA Mount CB1 to ON
(5) Pull RT-B/SARM RT PA straight forward to clear PA Mount	(5) Set VAA or PSA MX-12275 CB1 to ON; if used, set LS-671 CB1 to ON

**g. RT-B/SARM RT Power Amplifier Mount (PA Mount):**

<b>TO REMOVE:</b>	<b>TO REPLACE:</b>
(1) Set VAA or PSA MX-12275 CB1 to OFF; if used, set LS-671 CB1 to OFF	(1) Place RT-B/SARM RT PA Mount on shelf
(2) Set RT-B/SARM RT PA Mount CB1 to OFF	(2) Connect CX-13291 to RT-B/SARM RT PA Mount J3
(3) Remove RT-B/SARM RT PA (refer to paragraph 5.2.f.)	(3) Connect CX-13303 to RT-B/SARM RT PA Mount J1
(4) Remove bolts (5), IET lockwashers (6), and nuts (8) from RT-B/SARM RT PA Mount	(4) Replace bolts (5), IET lockwashers (6), and nuts (8) securing RT-B/SARM RT PA Mount to shelf
(5) Remove CX-13291 from RT-B/SARM RT PA Mount J3	(5) Replace RT-B PA/SARM RT in PA Mount (refer to paragraph 5.2.f.)
(6) Remove CX-13303 from RT-B/SARM RT PA Mount J1	(6) Set RT-B/SARM RT PA Mount CB1 to ON
(7) Remove RT-B/SARM RT PA Mount from shelf	(7) Set VAA or PSA MX-12275 CB1 to ON; if used, set LS-671 CB1 to ON





**5.2. COMPONENT REPLACEMENT.** Continued

**h. Loudspeaker (LS-671) (Shelf Mount):**

TO REMOVE:	TO REPLACE:
(1) Set LS-671 CB1 to OFF	(1) Place loudspeaker (6) in position under radio shelf (4)
(2) Remove mounting base from radio shelf (4)	(2) Replace retaining bolts (1) and washers (2, 3)
(3) Remove all cables from connectors	(3) Replace all cables on connectors
(4) Remove retaining bolts (1) and washers (2, 3)	(4) Replace mounting base on radio shelf (4)
(5) Remove loudspeaker (6) from radio shelf (4)	(5) Set LS-671 CB1 to ON

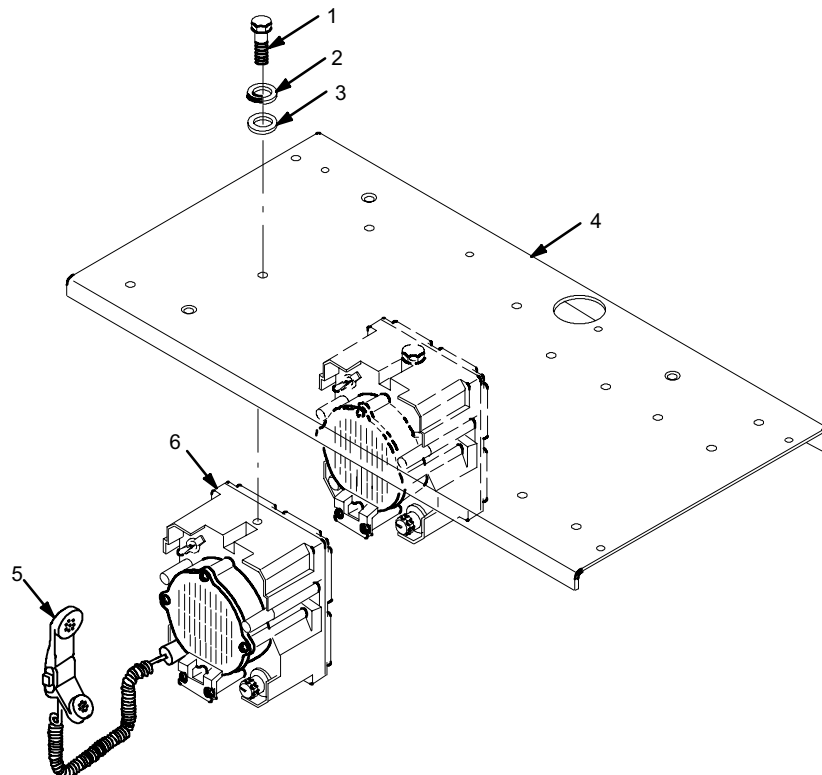

**5.2. COMPONENT REPLACEMENT.** Continued

**i. Loudspeaker (LS-671) (Dashboard Mount):**

TO REMOVE:	TO REPLACE:
(1) Set LS-671 CB1 to OFF	(1) Place loudspeaker (7) in position on mounting plate (8)
(2) Remove all cables from connectors	(2) Replace two retaining screws (6)
(3) Remove two retaining screws (6)	(3) Replace all cables on connectors
(4) Remove loudspeaker (7) from mounting plate (8)	(4) Set LS-671 CB1 to ON

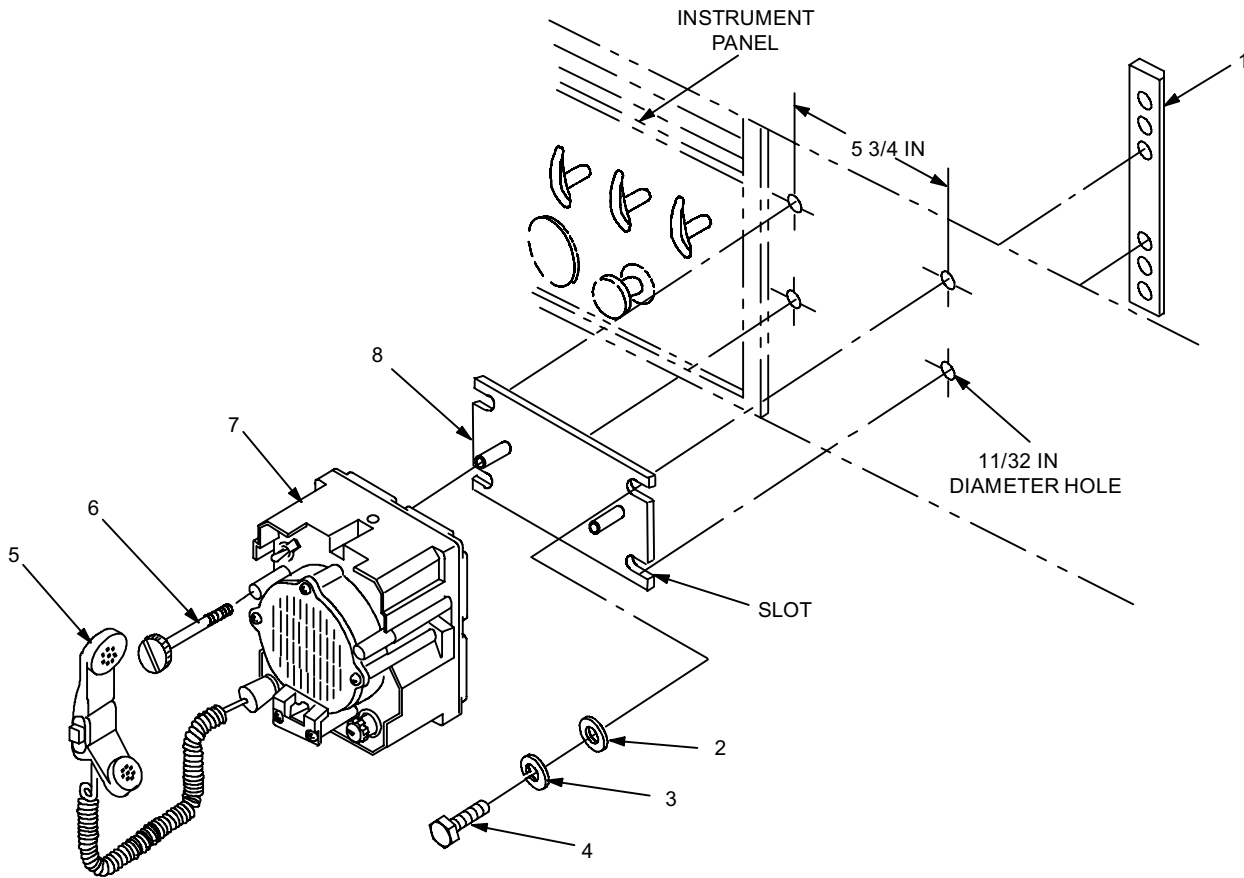

**5.2. COMPONENT REPLACEMENT.** Continued

**j. Vehicular Antenna Elements:**

TO REMOVE:	TO REPLACE:
(1) Remove RF cable from antenna subassembly (refer to paragraph 5.2.k.) (2) Remove safety wire securing antenna element (2) to antenna base spring (3) (3) Remove antenna elements (1, 2) from antenna base spring (3) by unscrewing antenna element (2) (4) Separate antenna elements (1, 2)	(1) Apply silicone compound to element threads and assemble antenna elements (1, 2) (2) Connect antenna element (2) to antenna base spring (3) (3) Install safety wire (4) to secure antenna element (2) to antenna base spring (3) (4) Install RF cable to antenna subassembly (refer to paragraph 5.2.k.) (5) Attach clip (5) to antenna element (1). Tie rope to vehicle to position antenna in desired location.

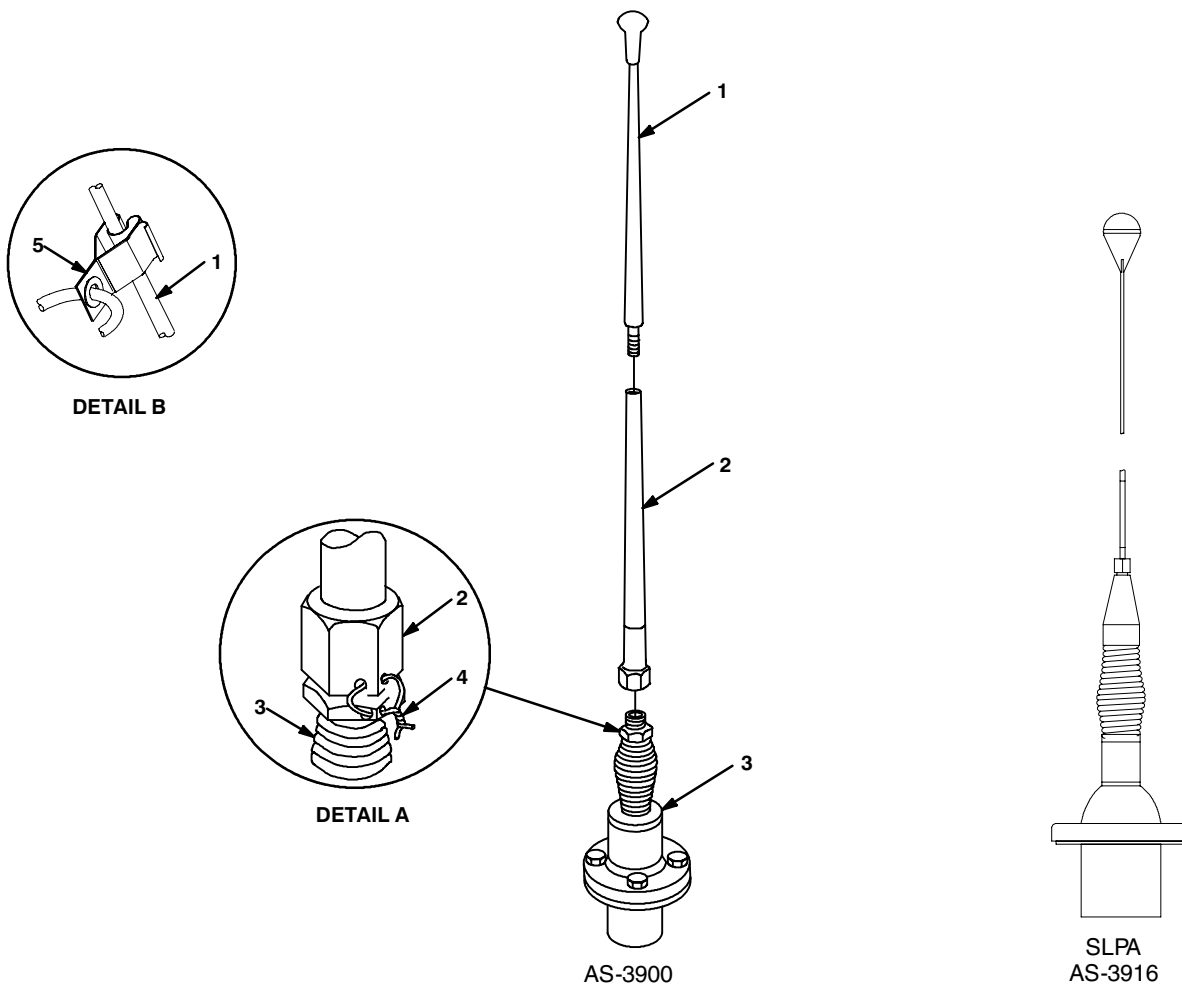

**5.2. COMPONENT REPLACEMENT.** Continued

**k. Vehicular Antenna Subassembly:**

TO REMOVE:	TO REPLACE:
(1) Remove RF cable (24) from antenna subassembly (17)	(1) Apply thin coat of silicone compound to both sides of gasket (20); place on antenna mounting bracket (22) and align holes
(2) Remove antenna elements from antenna subassembly (17) (refer to paragraph 5.2.j.)	(2) Place antenna subassembly (17) on antenna mounting bracket (22) and align holes
(3) Remove 4 cap screws (18), 8 IET lockwashers (19), 4 nuts (21) securing antenna subassembly (17) and gasket (20) to antenna mounting bracket (22)	(3) Install screw and lockwasher securing ground (23) to antenna subassembly (17)
(4) Remove screw and lockwasher securing ground (23) to antenna subassembly (17)	(4) Coat washers (19) with RTV sealing compound
(5) Remove antenna subassembly (17)	(5) Install 4 cap screws (18), 8 IET lockwashers (19), and 4 nuts (21) securing antenna subassembly (17) and gasket (20) to antenna mounting bracket (22)
	(6) Install antenna elements to antenna subassembly (17) (refer to paragraph 5.2.j.)
	(7) Install RF cable (24) to antenna subassembly (17)

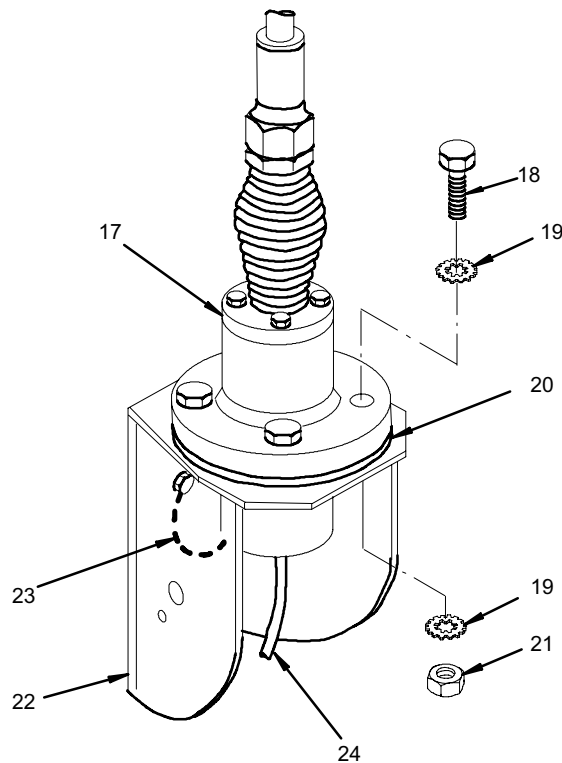

### 5.3. COMPONENT REPAIR.

The following charts show, by component, those items to be repaired at unit maintenance and those actions required by the Unit Maintainer to accomplish authorized repairs. While this paragraph contains instructions for complete disassembly of some components, Mounting Base MT-6352 series for example, the extent to which the Unit Maintainer will repair such items depends primarily upon unit SOP and maintenance policy.

The Antenna Connector J1 of the RT front panel is being changed from a DS to a unit maintenance task. The change requires application of a Modification Kit by DS Maintenance. Once the modification is installed, the brass-colored J1 connector will be replaced by a silver-colored connector. When it becomes necessary to replace a silver-colored J1 connector, that task is a unit maintenance responsibility. Replacement of brass-colored J1 connectors continues to be a DS maintenance task, performed only when the item is damaged. This paragraph provides instructions for replacement of the silver-colored connector.

**a. RECEIVER-TRANSMITTER (RT)(RT-1523 SERIES):**

MAINTENANCE REQUIREMENT:	ACTIONS:
(1) Replace handle (6) on RT-1523 series	(1) Remove connector cover (9) from handle (6) (RT-1523) (2) Remove 4 screws from side of RT (RT-1523/B/C), or 2 screws from top of handle (RT-1523A/D) (3) Install new handle (6) (4) Replace screws and tighten (5) Replace connector cover (9) (RT-1523)
(2) Replace silver-colored antenna connector (5)	(1) Remove screws (4) from connector (5) (2) Remove connector (5) (3) Install good connector (5) (4) Tighten set screw (4)
(3) Replace front panel control knob (10) (RT-1523/B/C/E/F)	(1) Loosen set screw (11) at side of knob (10) (2) Remove knob from shaft (3) Install good knob (10) (4) Tighten set screw (11)
(4) Replace front panel control knob (RT-1523A/D)	(1) Loosen screw in top of knob (2) Remove screw and washer (3) Remove knob from shaft (4) Install good knob (5) Place washer on shaft (6) Holding knob, tighten screw
(5) Replace strike catch (7) N/A for RT-1523E/F	(1) Loosen and remove screws (2) Remove catches (7) (3) Install good catch (7) (4) Apply sealing compound (Grade H) to screws (5) Install and tighten screws

5.3. COMPONENT REPAIR. Continued

a. RECEIVER-TRANSMITTER (RT)(RT-1523 SERIES): Continued

MAINTENANCE REQUIREMENT:	ACTIONS:
(6) Replace connector cover (9)	(1) Remove connector cover (9) from handle (6) (RT-1523/B/C) (2) Remove screw securing cover to handle (RT-1523A/D) (3) Install new connector cover (9) (4) Tighten screw to handle (RT-1523A/D)
(7) Replace hold-up (HUB) battery (3) N/A for RT-1523E/F	(1) Fully loosen captive screws (1) (2) Remove cover (2) (3) Remove battery (3) (4) Install battery with correct polarity (5) Install cover and tighten screws
(8) Replace display cover (12) ( RT-1523E/F)	(1) Remove display cover (12) from display (2) Install display cover (12) to display

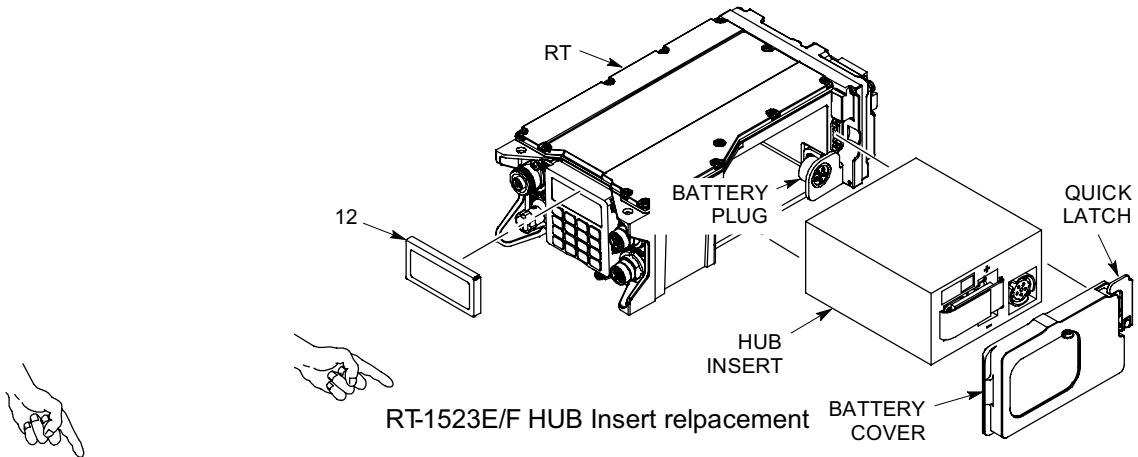
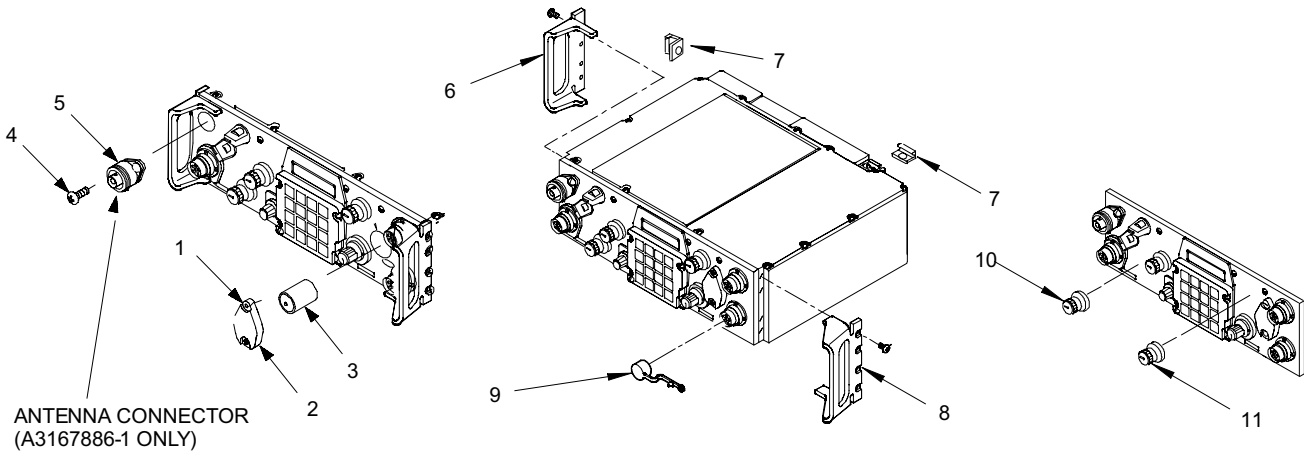

\* RT-1523E/F does not have replaceable handles or HUB battery. HUB insert performs hold up function.

**5.3. COMPONENT REPAIR.** Continued

**b. VEHICULAR AMPLIFIER-ADAPTER (VAA) (AM-7239 SERIES):**

MAINTENANCE REQUIREMENT:	ACTIONS:
(1) Replace DS1 lamp/lens (7, 8)  <p style="text-align: center;"><b><u>CAUTION</u></b></p> The AM-7239B/C/E have a 13 V dc DS1 lamp. The AM-7239, AM-7239A and LS-671 DS1s are rated for 28 V dc.	(1) Turn lens (8) CCW to remove (2) Pull lens from holder (3) Replace lamp/lens (7, 8) (4) Insert lens and turn CW to tighten
(2) Replace inject/eject lever (15)	(1) Remove nut (18) and washers (17, 16) (2) Remove lever (15) and washer (16) (3) Install good lever (15) and washer (16) (4) Install washers (16, 17) (5) Apply lubricating oil to threads (6) Install nut (18) and tighten
(3) Replace RT shelf (AM-7239 and AM-7239B/C/E only)	(1) Remove inject/eject lever (bottom shelf only) (2) Remove retaining hardware (3) Remove damaged shelf (4) Install good shelf (5) Replace hardware and tighten (6) Install inject/eject lever (bottom shelf only)
(4) Replace thumbscrew	(1) Remove pin spring, if present and retaining ring (2) Turn thumbscrew CCW and remove (3) Remove washer, retaining ring, and rim clamp from thumbscrew (4) install retaining ring, rim clamp, and washer on good thumbscrew (5) Turn thumbscrew CW to install (6) Install retaining ring and pin spring, if present
(5) Replace connector cover	(1) Remove retaining hardware (2) Remove cover (3) Install good cover (4) Install retaining hardware and tighten
(6) Replace seal screw	(1) Remove defective seal screw (2) Install good seal screw

**5.3. COMPONENT REPAIR.** Continued

**b. VEHICULAR AMPLIFIER-ADAPTER (VAA) (AM-7239 SERIES):** Continued

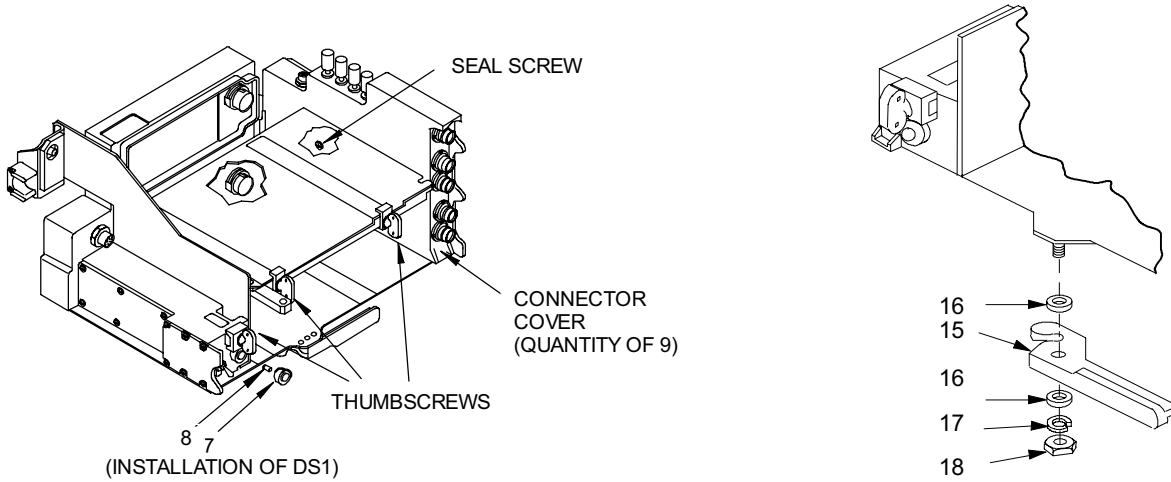

**c. MOUNTING BASE (MT-6352 SERIES):**

MAINTENANCE REQUIREMENT:	ACTIONS:
(1) Replace connector assembly (1)	(1) Remove screw and 2 washers securing ground to lower rear of connector assembly (2) Remove screw and 2 washers securing ground to top of connector assembly (3) Remove 5 screws, with 2 washers each, securing connector assembly to mounting base (4) Lift connector assembly from mounting base (5) Position good connector assembly on mounting base (6) Secure connector assembly to base using 5 screws, 2 washers each (ensure lockwasher is between screw head and flat washer) (7) Replace top and rear grounds using screw and 2 washers for each (ensure IET lockwasher is between ground and connector assembly)
(2) Replace ground lead (5, 6, 7)	(1) Remove connector assembly (2) Remove 16 screws from top tray (3) Remove screw, 3 washers, and nut securing ground to bottom tray (4) Remove screw, 3 washers, and nut securing ground to top tray (5) Position good ground lead on bottom tray (6) Secure ground to bottom tray using screw, 3 washers, and nut (see figure and ensure IET lockwashers are in their proper position) (7) Repeat for ground to top tray (8) Install 16 screws to top tray (9) Install connector assembly



**5.3. COMPONENT REPAIR.** Continued

**c. MOUNTING BASE (MT-6352 SERIES):** Continued

<b>MAINTENANCE REQUIREMENT:</b>	<b>ACTIONS:</b>
(3) Replace all 4 shock mounts (2)	(1) Remove connector assembly (2) Remove 16 screws from top tray (3) Remove 4 ground leads from top tray (4) Remove 4 screws securing bottom tray to shock mounts (5) Using 4 screws, secure good shock mounts to bottom tray (6) Install ground leads to top tray (7) Install 16 screws to top tray (8) Install connector assembly
(4) Replace inside thumbscrew (3)	(1) Remove connector assembly (2) Remove 16 screws from top tray (3) Remove 4 ground leads from top tray (4) Remove spring pin from thumbscrews (5) Remove washer from thumbscrew end (6) Remove thumbscrew, rim clenching clamp, and retaining ring (7) Install rim clenching clamp and retaining ring on good thumbscrew (8) Install thumbscrew in top tray (9) Place flat washer on thumbscrew (10) Install spring pin in end of thumbscrew (11) Install 4 ground leads to top tray (12) Install 16 screws to top tray (13) Install connector assembly
(5) Replace outside thumbscrews (4)	(1) Remove thumbscrew, washer, rim clenching clamp, and retaining ring (2) Install good thumbscrew, washer, rim clenching clamp, and retaining ring
(6) Replace locking bar bracket (9)	(1) Loosen and remove 2 screws (2) Remove locking bar bracket (3) Install good bracket and tighten 2 screws
(7) Replace seal screw on back of connector assembly	(1) Remove seal screw with O-ring (2) Install good seal screw and O-ring
(8) Replace connector cover	(1) Remove connector cover from retainer (2) Secure connector cover to retainer

5.3. COMPONENT REPAIR. Continued

c. MOUNTING BASE (MT-6352 SERIES): Continued

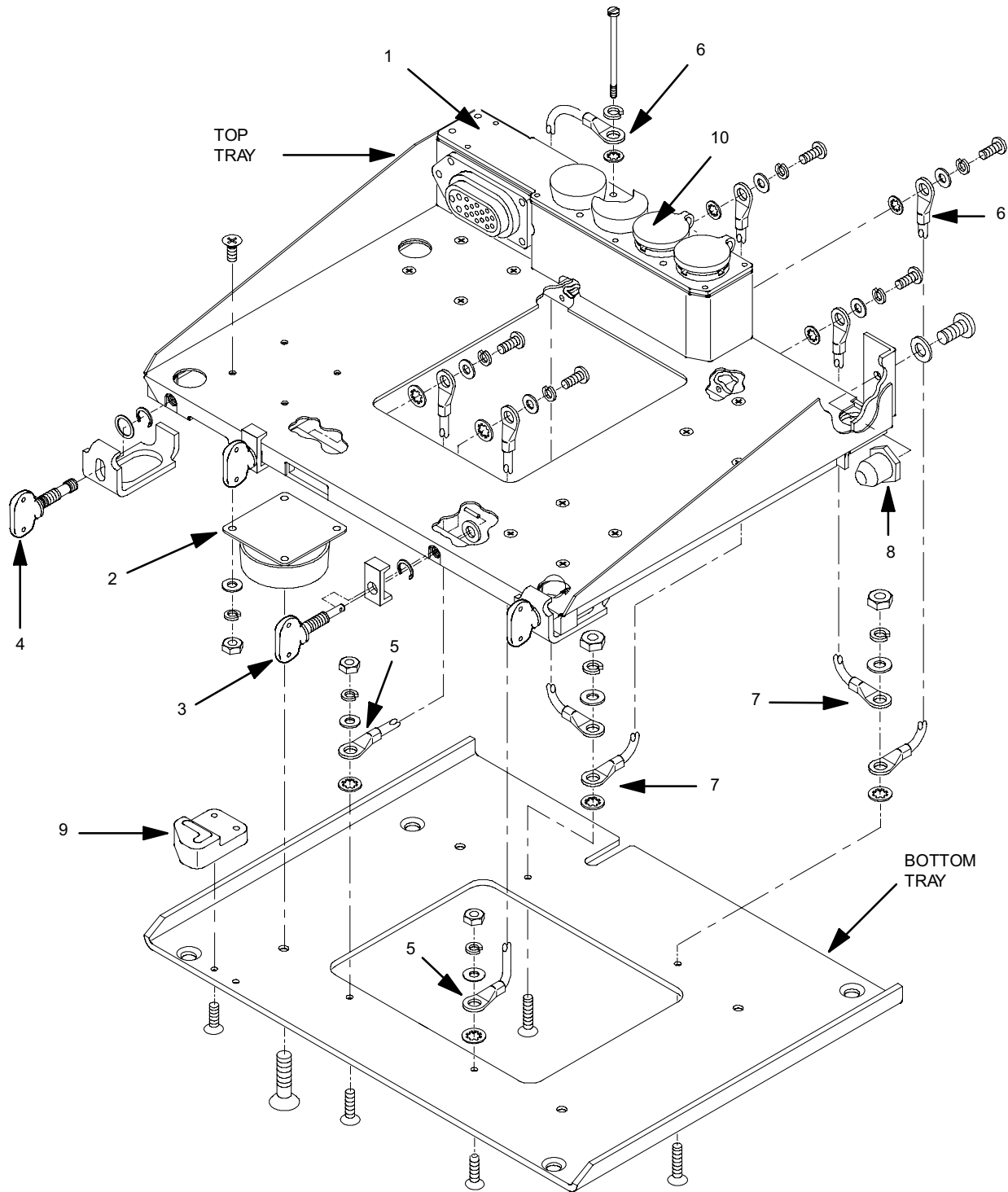

**5.3. COMPONENT REPAIR.** Continued

**d. POWER SUPPLY ADAPTER (PSA) (MX-12275):**

MAINTENANCE REQUIREMENT:	ACTIONS:
(1) Replace seal screw (1)	(1) Remove seal screw (1) (2) Install good seal screw
(2) Replace connector covers (2,3,4,5)	(1) Remove connector covers (2,3,4,5) (2) Install good connector covers
(3) Replace all four shock mounts (6) / mounting plate (7)	(1) Remove 2 ground leads from mounting tray  (2) Remove 4 screws securing mounting base to mounting tray (3) Remove 4 screws securing mounting base to shock mount (6) (4) Repeat step (3) for each shock mount (5) Using 4 screws, secure good shock mount (6) to mounting base (6) Repeat step (5) for each shock mount (7) Install mounting base to mounting tray (8) Install ground leads to mounting tray
(4) Replace ground strap (8,9)	(1) Remove screw, 2 washers, and nut securing ground strap (8,9) to mounting base  (2) Remove screw, 2 washers, and nut securing ground strap (8,9) to mounting tray (3) Position good ground strap (8,9) on mounting base (4) Secure good ground strap (8,9) to mounting base using screw, 2 washers, and nut (see fig and ensure IET lockwashers are in their proper position) (5) Repeat step (4) for ground strap (8,9) to mounting tray
(5) Replace thumbscrew (10) / rim clamp (11)	(1) Turn thumbscrew (10) CCW and remove  (2) Remove rim clamp (11) from thumbscrew (10) (3) Install good rim clamp (11) on good thumbscrew (10) (4) Turn thumbscrew (10) CW to install

5.3. COMPONENT REPAIR. Continued

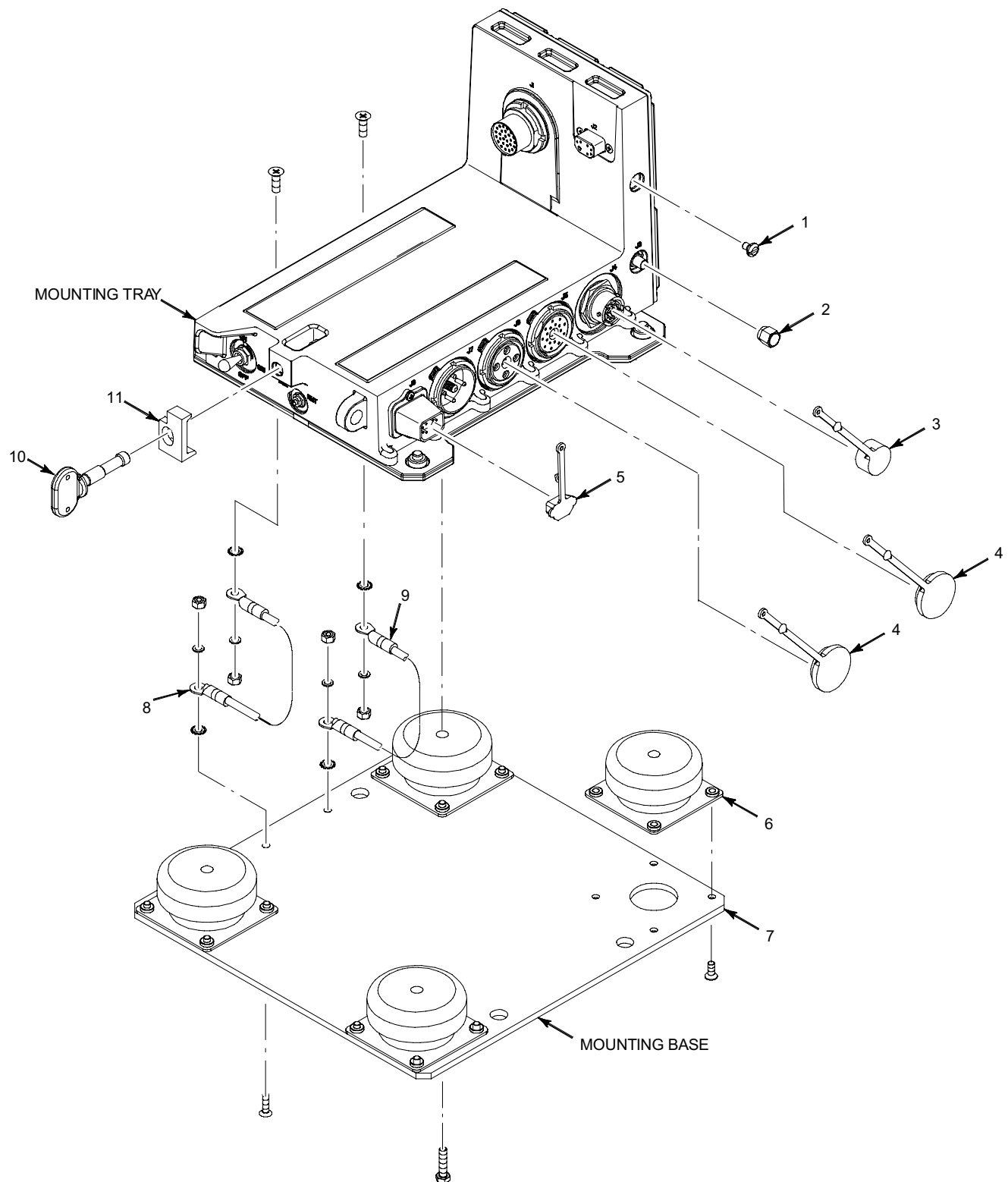

**5.3. COMPONENT REPAIR.** Continued

**e. POWER AMPLIFIER MOUNT (PA MOUNT) (MT-6353):**

MAINTENANCE REQUIREMENT:	ACTIONS:
(1) Replace power supply chassis (1)	(1) Remove 4 hex bolts and 8 washers securing bottom base to power supply chassis (2) Position good power supply chassis (3) Install 4 hex bolts and 8 washers securing bottom base to power supply chassis
(2) Replace ground strap (7)	(1) Remove power supply chassis (2) Remove nut (19), screw (20), and 2 washers (18) securing ground strap to bottom base (3) Remove nut, screw, and 3 washers securing ground strap to power supply chassis (4) Position good ground strap on bottom base and secure with hardware (5) Secure good ground strap with hardware to power supply chassis (6) Install power supply chassis
(3) Replace thumbscrew/rim clamp	(1) Remove retaining ring (2) Unscrew thumbscrew (3) Remove rim clamp and 2 washers (4) Install good rim clamp and 2 washers on good thumbscrew (5) Install thumbscrew (6) Install retaining ring
(4) Replace DS1 lamp (2) / lens (3)	(1) Turn lens CCW to remove (2) Pull lens from holder (3) Replace lamp/lens (4) Install lens and turn CW to tighten
(5) Replace all 4 shock mounts (15)/mounting plate (16)	(1) Remove power supply chassis (2) Remove 16 screws (17) from mounting plate (3) Position 4 shock mounts on mounting plate (4) Install 16 screws and tighten (5) Install power supply chassis
(6) Replace connector cover	(1) Remove connector cover from retainer (2) Secure connector cover to retainer

5.3. COMPONENT REPAIR. Continued

e. POWER AMPLIFIER MOUNT (PA MOUNT) (MT-6353): Continued

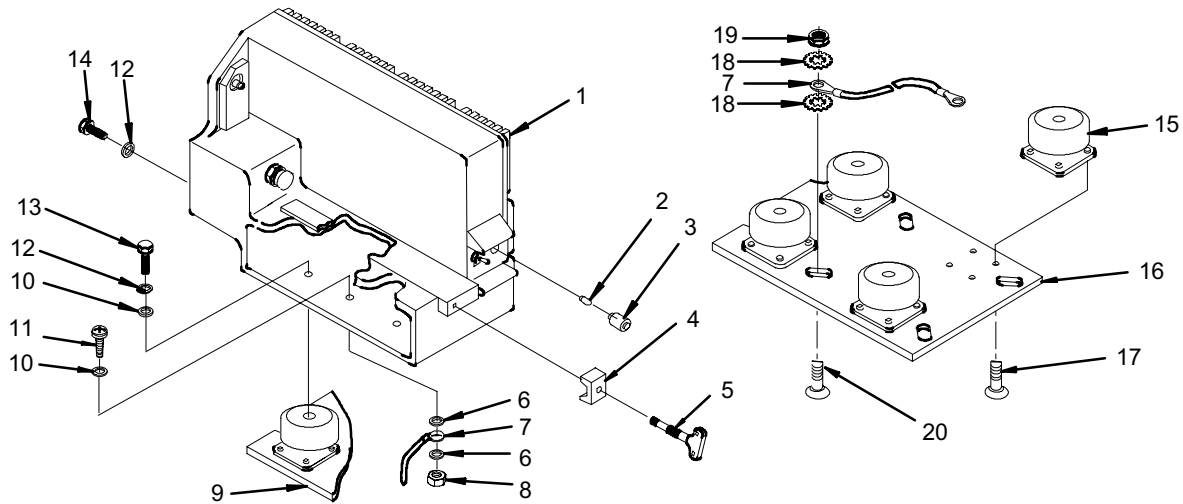

f. LOUDSPEAKER LS-671:

MAINTENANCE REQUIREMENT:	ACTIONS:
(1) Replace DS1 lamp/lens (2)	(1) Turn lens CCW to remove (2) Pull lens from holder (3) Replace lamp/lens (2) (4) Install lens and turn CW to tighten
(2) Replace control knob (3)	(1) Loosen set screw and remove knob (2) Install good knob (3) (3) Tighten set screw
(3) Replace loudspeaker grill (1)	(1) Remove 6 screws and washers (2) Remove damaged grill (1) (3) Install good grill (1) (4) Secure with 6 screws and washers

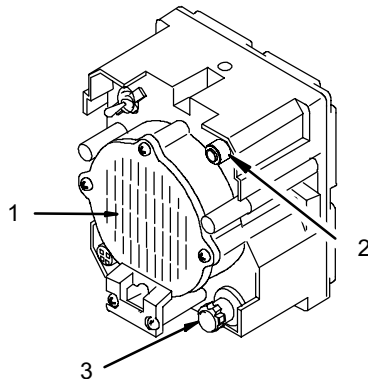

**5.3. COMPONENT REPAIR.** Continued

**g. VEHICULAR ANTENNAS (AS-3900A) (AS-3916 is not repairable):**

MAINTENANCE REQUIREMENT:	ACTIONS:
(1) Replace/clean/lubricate antenna elements (1, 2) (AS-3916 does not disassemble)	(1) Remove RF cable (6) from antenna subassembly (2) Cut safety wire (3) (3) Unscrew antenna from antenna base (4) Unscrew upper and lower antenna elements (1, 2) (5) Clean, lubricate with silicone compound, or replace as appropriate (6) Install antenna elements (1, 2) (7) Install safety wire (3) (8) Install RF cable (6) to antenna subassembly
(2) Replace antenna subassembly (4)	(1) Remove antenna elements (1, 2) (2) Remove 4 bolts, with 2 washers each, and 4 nuts from antenna base and bracket (3) Remove ground strap (7) from antenna subassembly (4) Remove gasket (5) and replace if required (5) Install good gasket on top of mounting bracket (6) Position good antenna subassembly on mounting bracket and install ground strap (7) (7) Coat all washers with Type III RTV compound (8) Install washer on each of 4 bolts (9) Install 4 bolts in base (10) Install washers and nuts and tighten (11) Install antenna elements
(3) Replace ground strap	(1) Remove antenna subassembly (2) Remove ground strap (7) from antenna mounting bracket (3) Install ground strap (7) to antenna mounting bracket (4) Install antenna subassembly

5.3. COMPONENT REPAIR. Continued

g. VEHICULAR ANTENNAS (AS-3900A/3916) Continued

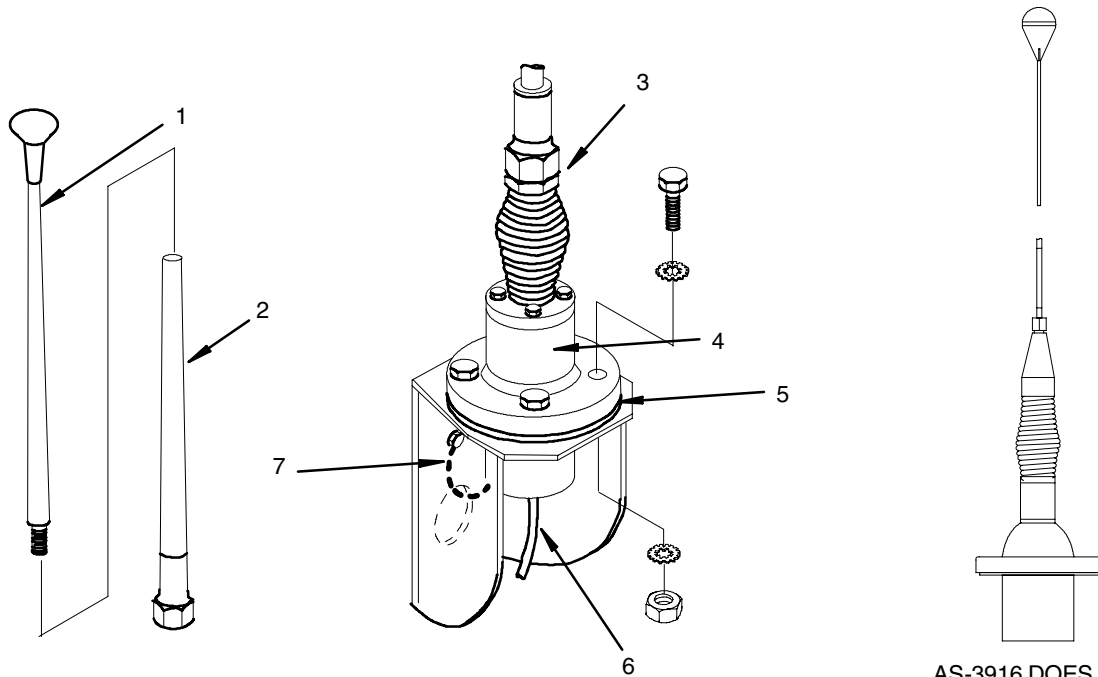

AS-3916 DOES NOT DISASSEMBLE

h. BATTERY BOX (CY-8523A/B):

MAINTENANCE REQUIREMENT:	ACTIONS:
(1) Replace catch, clamping	(1) Remove screws (2) Remove washers (3) Replace damaged catch, clamping (4) Install washers (5) Install screws
(2) Replace strike catch	(1) Remove screws (2) Remove washers (3) Replace damaged strike catch (4) Install washers (5) Install screws
(3) Replace battery box cover (CY-8523A/C only)	(1) Remove two catch, clamping (2) Replace damaged battery box cover (3) Install two catch, clamping



5.3. COMPONENT REPAIR. Continued

h. BATTERY BOX (CY-8523A/B): Continued

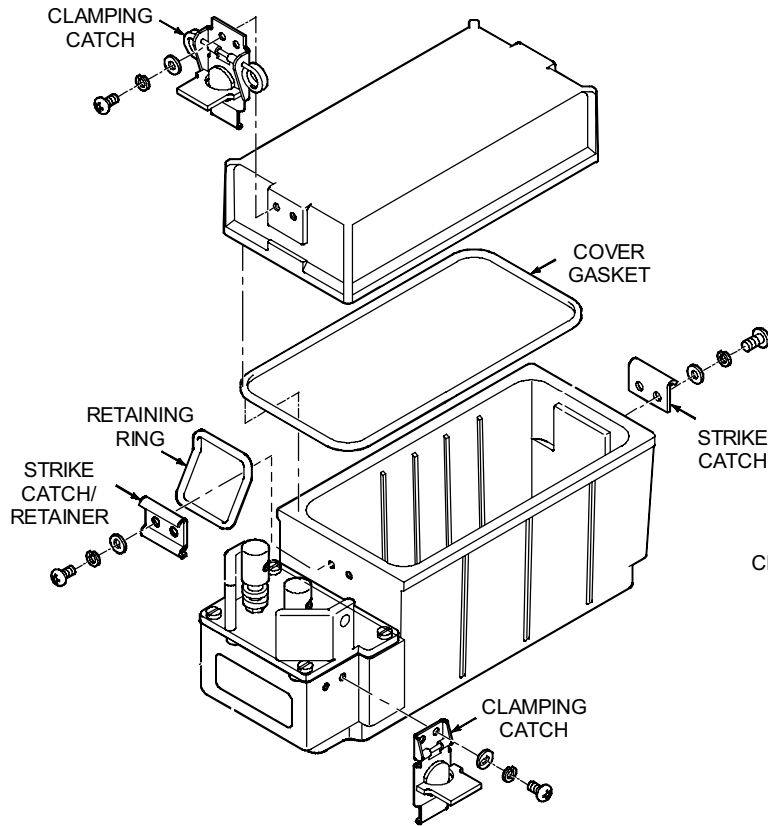

CY-8523A

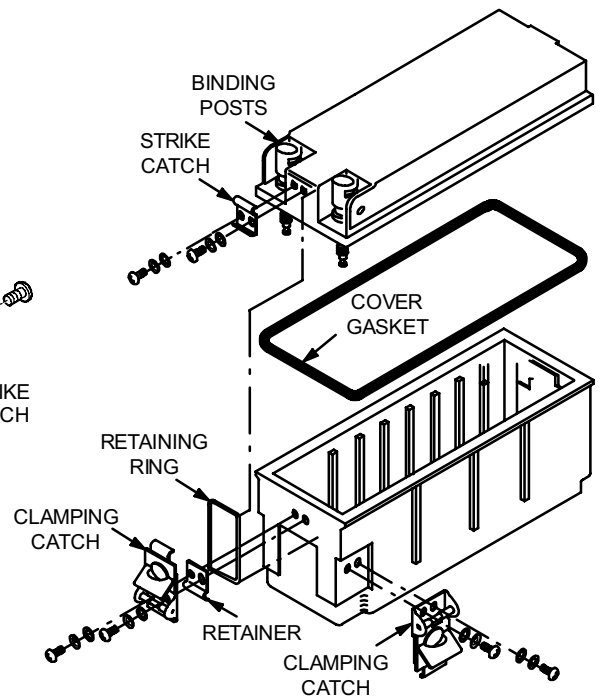

CY-8523B

5.3. COMPONENT REPAIR. Continued

h. BATTERY BOX (CY-8523C): Continued

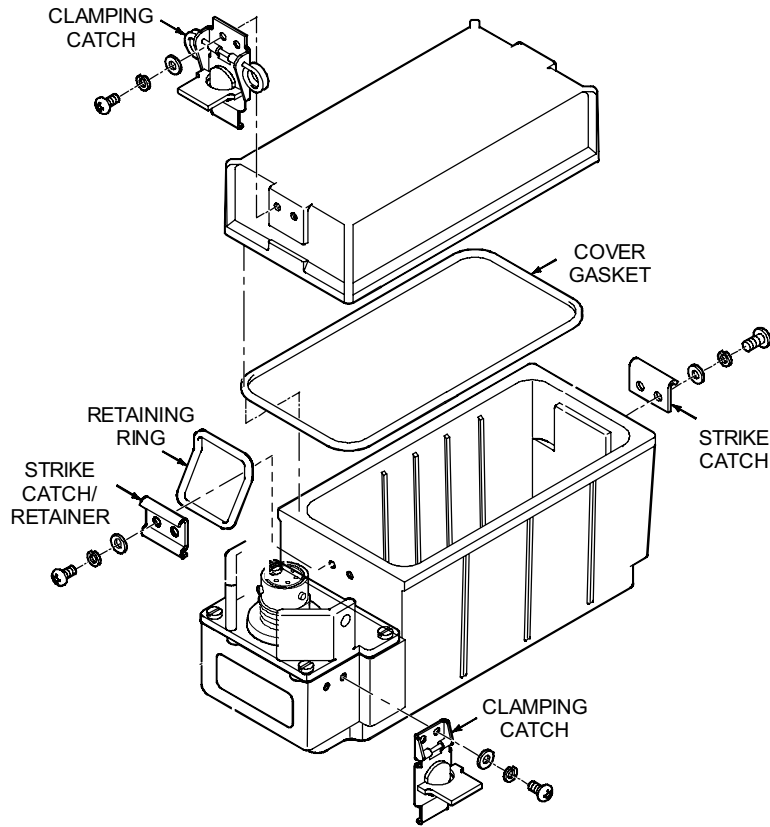

CY-8523C

i. HRCRD (C-12493/U):

MAINTENANCE REQUIREMENT:	ACTIONS:
(1) Replace knob	(1) Remove damaged knob (2) Install good knob

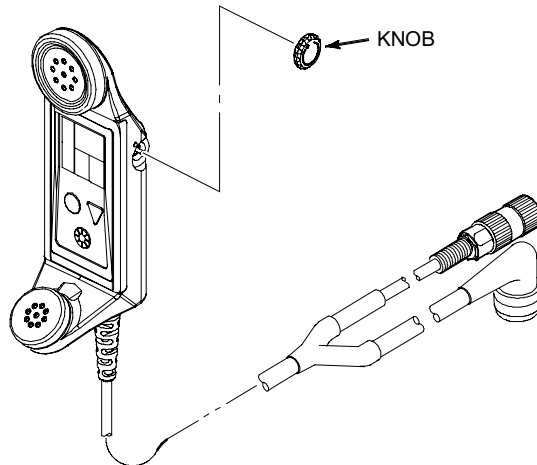

## CHAPTER 6

### SINGLE ASIP RADIO MOUNT (SARM)

Subject	Para	Page
Principles of Operation .....	.6.1	6-1
Operational Check .....	.6.2	6-6
Troubleshooting Flowcharts .....	.6.3	6-12

#### 6.1. PRINCIPLES OF OPERATION.

This section covers the principles of operation for the AN/VRC-87G and AN/VRC-90G configurations.

#### NOTE

The LS-671 and PA will only operate when installed in vehicles that provide power in the 22 to 32 V dc range.

##### a. DC POWER INPUT AND DISTRIBUTION.

- (1) **Vehicular Power.** The vehicle battery input voltage may vary from 9 to 32 V dc. The PSA MX-12275 is connected to the battery by a power cable. In some vehicles, the cable is connected to a terminal block which is connected to the battery.

The power cable has a four-pin connector that connects to J7 on the PSA MX-12275. Pin A of the power cable is the black lead which connects to the negative terminal. Pin B of the power cable is the red lead which connects to the positive terminal.

- (2) **Power Distribution in Power Supply Adapter (PSA) MX-12275.** The 9 to 32 V dc enters the PSA MX-12275 on pin B of connector J7. Pin B is connected to CB1 which provides over-current protection. A LCL/RMT switch is provided to place the PSA MX-12275 in local or remote mode. In local mode, the voltage present at J7 pin B enables the power to the DC-DC converter. In remote mode, the voltage sent from a AN/VIC-1(V) or LS-671 loudspeaker to J7 pin C or J5 pin D enables the DC-DC converter. The DC-DC converter provides + 13V operating power to the RT. The over/under voltage shutdown provides protection for the other circuitry in the PSA MX-12275.

**MX-12275/VRC Power Distribution**

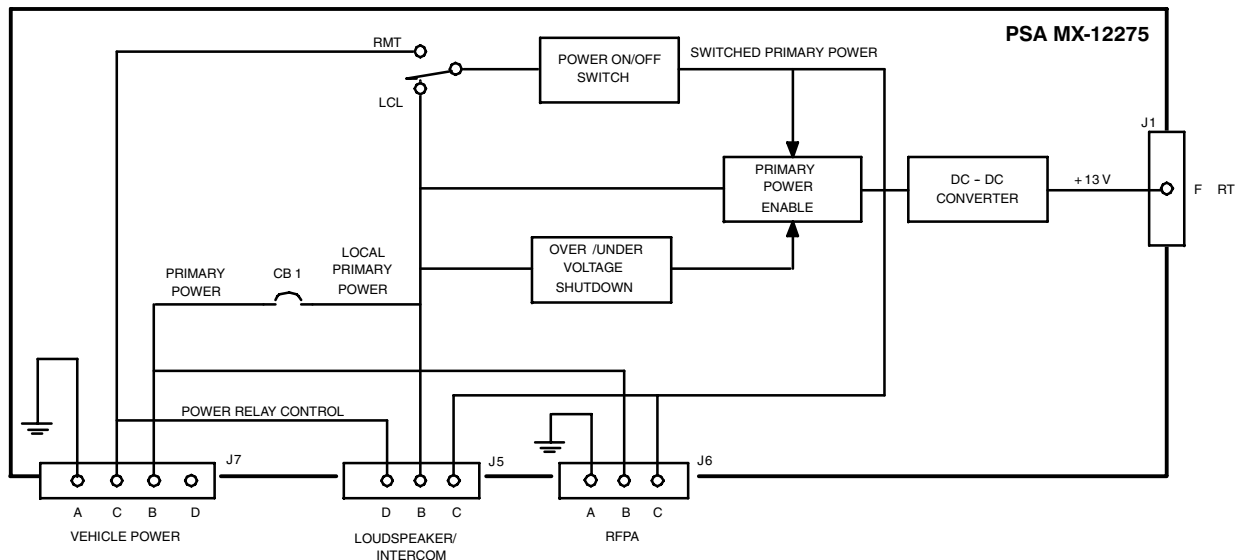

- (3) **Remote Control.** An LS-671 or AM-1780 can remotely power up the PSA MX-12275 if it is set to the remote mode.

Primary power enters the PSA MX-12275 at connector J7, pin B. From there, it is distributed to PSA MX-12275 J5, pin B. Cables carry the dc on J5, pin B to an LS-671 or AM-1780. If the LS-671 ON/OFF switch is set to ON or the AM-1780 MAIN PWR switch is set to NORM, the dc on PSA MX-12275 J5, pin B is returned on PSA MX-12275 J5, pin D.

DC power on PSA MX-12275 J5, pin D energizes the power on/off switch in the PSA MX-12275, allowing power to exit on PSA MX-12275 J5, pin C. The cables then send the power on PSA MX-12275 J5, pin C to the LS-671 or AM-1780 in order to power their audio amplifiers.

DS1 will light at the LS-671 indicating power is present. DS501 will light at the AM-1780 if CB501 is set to ON.

The cables and interconnects that provide for remote power are as follows:

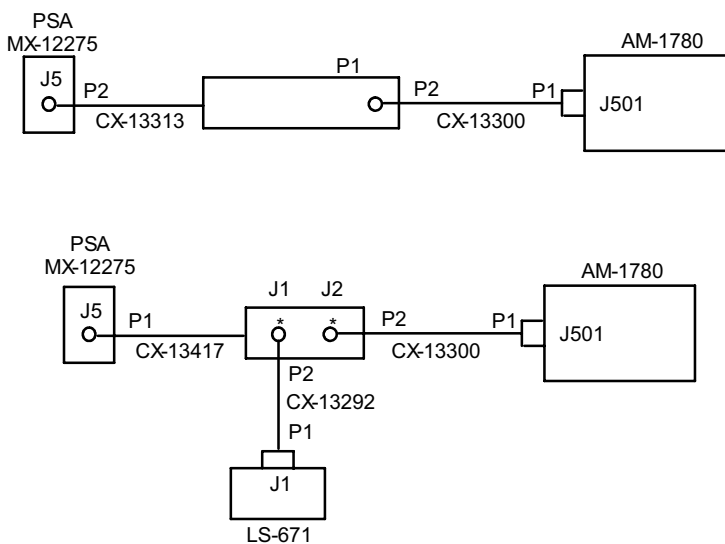

\* CX-13292 and CX-13300 may be connected to J1 or J2 of CX-13417.

- (4) **Power Distribution in Power Amplifier Mount (PA mount) MT-6353.** The 22 to 32 V dc enters the PA mount through J1, pin B from J6, pin B of the PSA MX-12275. The 22 to 32 V dc used to energize the K1 relay enters the PA mount through J1, pin C from J6, pin C of the PSA MX-12275. When CB1 of the MX-12275 is set to ON, 22 to 32 V dc will be applied to J1, pin C of the PA mount causing the K1 relay to energize. This allows the 22 to 32 V dc at J1, pin B to be applied to power supply A1 of the PA mount when CB1 is set to ON. This, in turn, allows DS1 to light.

**PA Mount MT-6353 Power Distribution**

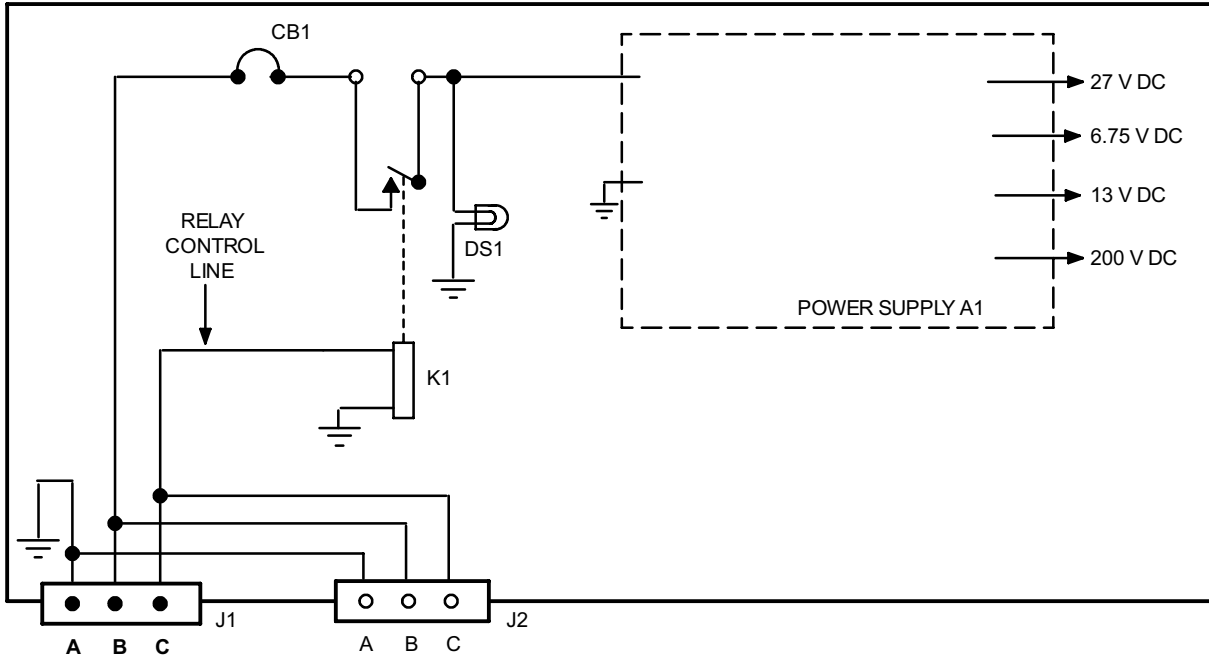

**b. POWER AMPLIFIER.**

- (1) **Power Output.** The RF power amplifier is used to extend the transmission range of the RT. The amplified RF output from the PA is a nominal 50 watts, but may vary from 30 to 70 watts. On the RT, in the PA setting, a nominal 4 watts is sent from the RT J1 to the PA J2, then amplified and fed to the antenna via the PA J1. In LO, M, or HI, the output of the RT passes through the PA with no amplification and is output to the antenna.
- (2) **RF Power Amplifier Keying Circuit.** The PA is keyed by the RT. When the PTT switch on the handset is pressed, the RT is keyed by placing a ground on pin C of RT AUD/DATA connector. When RF PWR is set to PA and the RT is keyed, 6.75 V dc is placed on RT, P1, pin H. The presence of 6.75 V dc on PA, P1, pin N, keys the PA. A power level signal is generated and sent to the RT signal display. All bars of the signal display light. The RT selects the proper PA filter. Failure of the RT to select the proper band will cause the PA to fail to transmit.
- (3) **RF Power Output Filtering.** The PA is a linear amplifier across the frequency band of 30 to 87.975 MHz. The PA has three sets of filters which are selected by the RT.

PA FILTER	OPERATING FREQUENCY (MHZ)	SELECTOR PIN PA CONNECTOR P1
A	30.0 to 43.0	P
B	43.0 to 61.4	R
C	61.4 to 88.0	M

(4) **Voltage Standing Wave Ratio (VSWR).** VSWR is the relative value of forward to reverse power. Any of these faults may cause high reflected power:

- Use of an old VRC-12 antenna or components
- Antenna elements broken, dirty or corroded
- Lower antenna element connector open
- Defective mounting base
- Rusty antenna base mounting bolts
- Loose or missing ground straps
- Wrong type RF cable installed (75 ohm data cable)
- Open RF cable grounds

The PA has a VSWR detector used to measure the reflected voltage. It is compared to the forward voltage to determine the VSWR. When this ratio exceeds 5 : 1, the PA RF output is automatically reduced to a safe level. The RF test set can be used to measure RVS PWR. When the 5 :1 VSWR is reached, RT sidetone is disabled (except with the AM-7238B/VRC RF PA).

(5) **PA Mount.** The long range radio uses a PA in a separate mount. The mount is cabled to the PSA MX-12275, where internal wiring connects the PA mount to the RT. Cable CX-13303 is used to provide dc power, and CX-13291 is used to pass control signals between the RT and PA.

**c. RADIO ANALOG RECEIVE PATH.**

Received voice signals are limited to the baseband bandwidth of 300 Hz to 3 kHz. The analog voice signal is amplified by the RT and sent to the AUD/DATA, AUD/FILL, and rear system connector P1.

The fixed level audio from the RT is filtered and amplified on the Power Supply CCA. The VIC receive audio is a high-level signal used by the VIC. The fixed audio signal is a low-level signal used by both the LS-671 and the VIC.

Variable audio is available if a handset is connected directly to the AUD/FILL or AUD/DATA connector.

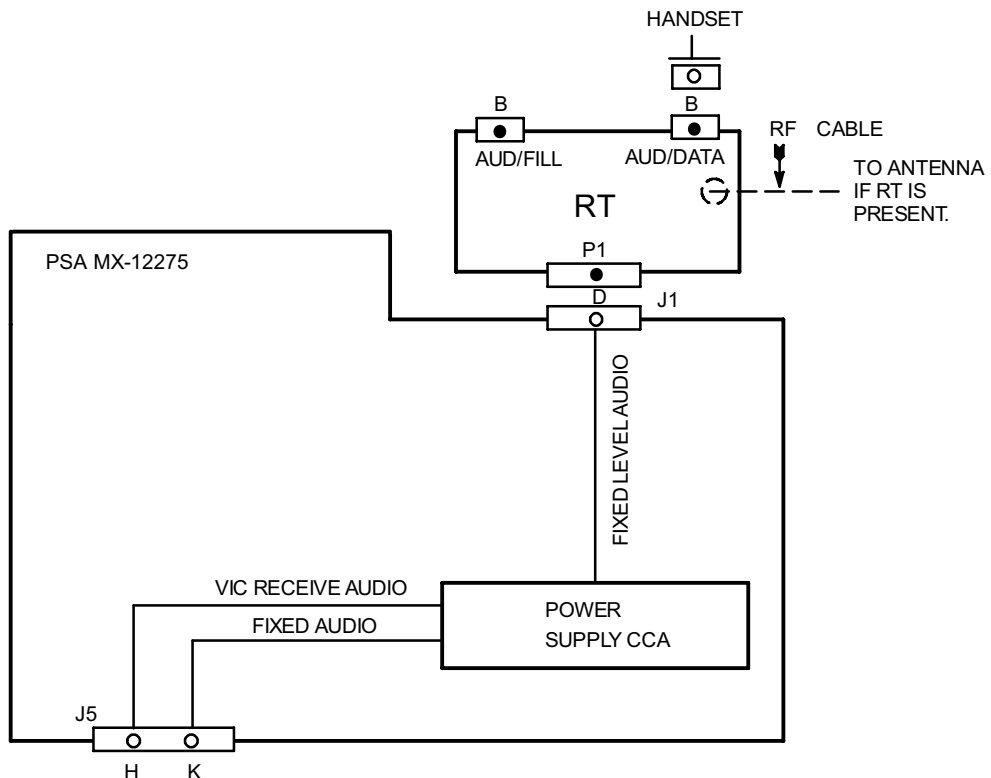

**d. RADIO ANALOG TRANSMIT PATH.**

The transmitter is keyed when the handset PTT is pressed. This places a ground on the handset audio connector pin C. In the vehicular installation, without an LS-671 or VIC, the handset is usually connected to the RT AUD/DATA connector. However, the handset may be connected to the AUD/FILL connector if needed.

A PTT command can also be generated by the LS-671 or VIC.

Audio signals are also generated by the VIC or LS-671. Cables pass these signals to PSA MX-12275 J5, pin U.

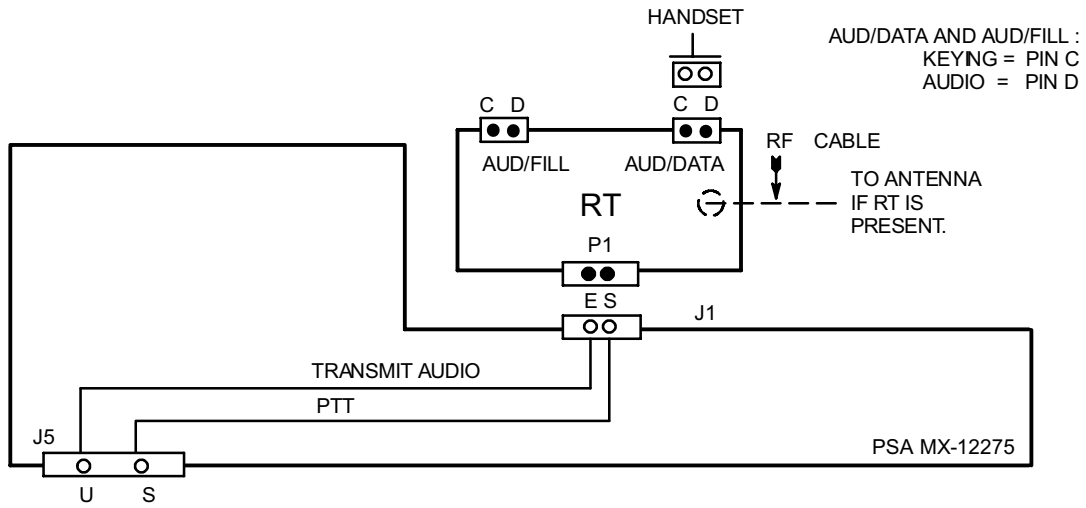

## 6.2. OPERATIONAL CHECK.

The operational check is a series of steps to evaluate equipment before placing the equipment in service and after repair. This check should be done with the equipment assembled.

### NOTE

To get valid results, the operational check **MUST** be followed exactly as written.

Step 1 of the operational check lists actions to establish a starting condition for the performance checklist that follows. The checklist is divided into steps. Each step tests how a component works alone and together in a system. The steps are numbered so they can be used for reference on maintenance worksheets. Each step is titled according to the function being checked.

### **IMPORTANT POINTS TO REMEMBER IN USING THE OPERATIONAL CHECK**

- When an Operational Check step involves an item of equipment which is not used in the system being checked, skip the appropriate portion of that step and continue to the next step.
  - It is important that Operational Check steps be performed as stated and in the order presented in the manual.
  - If the vehicular radio system being checked includes an AN/VIC-1 (VIC) intercom, determine as early as possible whether the problem is in the VIC or the radio; then troubleshoot that part of the system. If you need to troubleshoot the VIC, see Chapter 2.
  - Once you have completed the Operational Check, and the problem appears to be solved, make a communications check (unless prohibited by unit SOP or the tactical situation) and repeat the Operational Check to ensure the system is completely operational.
-



6.2. OPERATIONAL CHECK. Continued

**OPERATIONAL CHECK FOR SARM**

**STEP 1. PREPARATION:**

STEPS TO PERFORM	CHECKS TO MAKE	ACTIONS TO TAKE
1.1 Set RT: FCTN to OFF	N/A	N/A
1.2 Set PSA MX-12275: CB1 to OFF	N/A If LS-671 or VIC is used: If neither is used:	N/A Ensure PSA MX-12275 is set to RMT (REMOTE). Ensure PSA MX-12275 is set to LCL (LOCAL).
1.3 Set LS-671: CB1 to OFF DS1 to Full CCW VOL to OUT/Mid-Range	N/A N/A N/A	N/A N/A N/A
1.4 Set PA Mount MX-6353: CB1 to OFF DS1 to Full CCW	N/A N/A	N/A N/A
1.5 Handset (HS), H-250: Connect to RT AUD/DATA J3	Ensure that HS used is operational	Install a known good HS

**STEP 2. POWER CHECKS:**

STEPS TO PERFORM	CHECKS TO MAKE	ACTIONS TO TAKE
2.1 Set PSA MX-12275 CB1 to ON. Set LS-671 CB1 to ON.	PSA MX-12275 CB1 trips?	NO: Continue ↓ YES: Go to TS Chart 1
	LS-671 CB1 trips?	NO: Continue ↓ YES: Replace LS-671
	LS-671 DS1 lights?	YES: Go to Step 2.2 NO: Go to TS Chart 2
2.2 Set RT FCTN to SQ ON.	RT display lights?	YES: Continue ↓ NO: Go to TS Chart 3
	RT displays WAIT, then another message.	YES: Go to Step 2.3 NO: Replace RT.
2.3 Set RT FCTN to Z.	RT display reads GOOD.	YES: Go to STEP 3 NO: Replace RT if it reads other than GOOD

**6.2. OPERATIONAL CHECK.** Continued

**STEP 3. RT SELF-TEST:**

STEPS TO PERFORM	CHECKS TO MAKE	ACTIONS TO TAKE
3.1 Set RT FCTN to SQ ON. Set RT VOLUME to 5. Set RT CHANNEL to 1. Set RT POWER to HI. Set RT MODE to SC. Set RT COMSEC to CT. Set RT DATA to OFF.	N/A	N/A
3.2 Set RT FCTN to TST.	RT passes self-test?	YES: Go to Step 3.3 NO: Disconnect cables/HS from RT; Continue ↓
	RT then passes self-test?	YES: Reconnect cables/HS; go to Step 3.3 NO: Replace RT
3.3 Set RT FCTN to LD and back to TST.	Beeps heard at HS or LS-671 during self-test?	YES: Go to Step 3.4 NO: Go to TS Chart 4
3.4 Set FCTN to LD. Set CHAN to MAN.	RT display reads 30000?	YES: Continue ↓ NO: Replace RT
	Steady tone heard at HS/loudspeaker?	YES: Go to STEP 4 NO: Replace RT

**STEP 4. LOAD CHECKS:**

STEPS TO PERFORM	CHECKS TO MAKE	ACTIONS TO TAKE
4.1 Load RT with SC frequencies: Chan 1: 41000 Chan 2: 54000 Chan 3: 75000	SC frequencies load properly?	YES: Go to Step 4.2 NO: Replace RT
4.2 Set RT MODE to FH. Load COMSEC and FH data in RT.*	RT accepts fill?	YES: Go to Step 4.3 NO: Go to TS Chart 5
4.3 Load test sync time (82/09:36).	Test sync time loads properly?	YES: Go to Step 4.4 NO: Replace RT.
4.4 Set RT to STBY.	RT shuts down properly?	YES: Go to Step 4.5 NO: Replace RT
4.5 Set CB1 to OFF Wait 1 min. Set CB1 to ON. Set FCTN to SQ ON.	N/A N/A RT retains COMSEC, FH, and SC data in both FH and SC modes?	N/A N/A YES: Go to STEP 5 NO: Replace RT

\* NOTE: If using an Automated Net Control Device (ANCD), follow ICOM Fill procedure to load COMSEC keys and FH data in all 6 channels. Otherwise, load COMSEC keys and FH data in Channels 1, 2, and 3.

**6.2. OPERATIONAL CHECK.** Continued

**STEP 5. TRANSMITTER CHECKS:\***

STEPS TO PERFORM	CHECKS TO MAKE	ACTIONS TO TAKE
5.1 Disconnect RF cable from RT ANT. Connect test set cable from test set RADIO to RT ANT. Connect vehicular antenna cable to test set ANT. Set test set MODE to FWD PWR. Set RT: CHAN to 1 MODE to SC	N/A N/A N/A N/A N/A N/A	N/A N/A N/A N/A N/A N/A
5.2 Press PTT and test set Push-To-Test .	Test set reads 2W or greater.	YES: Go to Step 5.3 NO: Go to TS Chart 6
5.3 Set test set MODE to RVS PWR. Press PTT and test set Push-To-Test .	N/A Test set reads no more than 1/3** of FWD PWR?	N/A YES: Go to Step 5.4 NO: Go to TS Chart 6
5.4 Press PTT.	RT SIG display reads 4 or more?	YES: Go to Step 5.5 NO: Replace RT
5.5 Set RT CHAN to 2. Repeat FWD and RVS PWR check for CHAN 2.	N/A Test set reads no more than 1/3** of FWD PWR?	N/A YES: Go to Step 5.6 NO: Go to TS Chart 6
5.6 Set RT CHAN to 3. Repeat FWD and RVS PWR check for CHAN 3.	N/A Test set reads no more than 1/3** of FWD PWR?	N/A YES: Go to Step 5.7 NO: Go to TS Chart 6
5.7 Set RT to CHAN 1. Press PTT, count into HS.	N/A Sidetone heard?	N/A YES: Go to Step 5.8 NO: Replace RT
5.8 Set test set MODE to FREQ. Press PTT and test set Push-To-Test .	N/A Test set reads 40998 to 41002?	N/A YES: Go to Step 5.9 NO: Replace RT
5.9 Set RT CHAN to 2. Press PTT and test set Push-To-Test .	N/A Test set reads 53998 to 54002?	N/A YES: Go to Step 5.10 NO: Replace RT
5.10 Set RT CHAN to 3. Press PTT and test set Push-To-Test .	N/A Test set reads 74998 to 75002?	N/A YES: Go to STEP 6 NO: Replace RT

\* If unit SOP or tactical situation prohibits transmitting, use dummy load realize that antenna cannot be checked.

\*\* If radio is used for data transmission, use 1/4 rather than 1/3 for these checks.

6.2. OPERATIONAL CHECK. Continued

For testing RF in Sc mode, use the following test setup:  
SHORT RANGE RADIOS

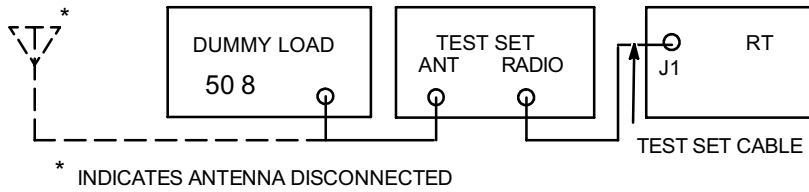

LONG RANGE RADIOS

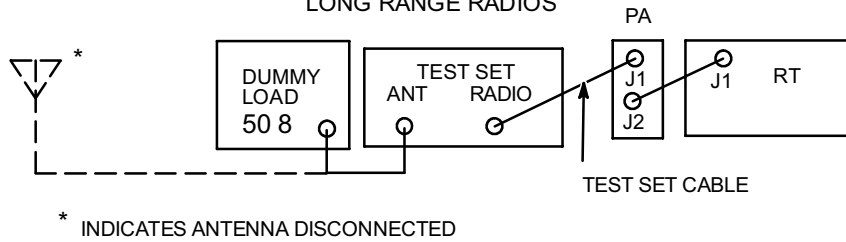

STEP 6. RECEIVER CHECKS:

STEPS TO PERFORM	CHECKS TO MAKE	ACTIONS TO TAKE
6.1 Disconnect vehicular antenna cable from test set ANT. Set test set MODE to SENS SQ Set RT: COMSEC to PT CHAN to 3	N/A N/A N/A N/A	N/A N/A N/A N/A
6.2 Press test set Push-To-Test.	Test tone heard in HS?	YES: Go to Step 6.3 NO: Replace RT
6.3 Connect HS to RT AUD/FILL. Set RT FCTN to SQ ON Press test set Push-To-Test.	N/A N/A Test tone heard in HS?	N/A N/A YES: Go to STEP 7 NO: Replace RT

**6.2. OPERATIONAL CHECK.** Continued

**STEP 7. POWER AMPLIFIER CHECKS:\***

STEPS TO PERFORM	CHECKS TO MAKE	ACTIONS TO TAKE
7.1 Connect vehicular antenna cable to test set ANT. Connect W2/CG-3856 cable to RT ANT and PA J2. Set test set MODE to FWD PWR. Connect test set cable from test set RADIO to PA J1. Set RT CHAN to 1.	N/A N/A N/A N/A N/A	N/A N/A N/A N/A N/A
7.2 Press PTT and test set Push-To-Test .	Test set reads 2–6 W FWD PWR?	YES: Go to Step 7.3 NO: Go to TS Chart 7
7.3 Set RT to PA. Press PTT and test set Push-To-Test .	N/A Test set reads 30 W or greater FWD PWR?	YES: Go to Step 7.4 NO: Go to TS Chart 8
7.4 Set RT CHAN to 2. Press PTT and test set Push-To-Test .	N/A Test set reads 30 W or greater FWD PWR?	N/A YES: Go to Step 7.5 NO: Go to TS Chart 9
7.5 Set RT CHAN to 3. Press PTT and test set Push-To-Test .	N/A Test set reads 30 W or greater FWD PWR?	N/A YES: Go to Step 7.6 NO: Go to TS Chart 9
7.6 Press PTT, and count into HS.	Sidetone heard at HS?	YES: Continue ↓ NO: Replace PA
	SIG display reads 6?	YES: Go to STEP 8 NO: Go to TS Chart 10

\* Skip this STEP if the tactical situation or your unit SOP precludes transmitting.

**STEP 8. LS-671 CHECKS:**

STEPS TO PERFORM	CHECKS TO MAKE	ACTIONS TO TAKE
8.1 Connect HS to LS-671 J2. Push LS-671 Volume IN. Set RT: COMSEC to CT MODE to SC POWER to HI	N/A N/A N/A N/A N/A N/A	N/A N/A N/A N/A N/A
8.2 Pull LS-671 Volume OUT. Press PTT, and count into HS.	N/A Sidetone heard at HS?	N/A YES: End of LS-671 checks* NO: Go to TS Chart 11

\* Return HS to operational position, if required.

**STEP 9. EGR CHECKS:**

STEPS TO PERFORM	CHECKS TO MAKE	ACTIONS TO TAKE
9.1 Load CID into RT.	CID loads?	YES: Continue ↓ NO: Replace RT.
9.2 Press GPS/5 key on RT.	Display reads NOGPS?	YES: EGR is not installed. End of operational check. NO: Continue ↓
	Display reads OFF?	YES: Turn GPS on, press GPS/5 key on RT, and continue ↓ NO: Continue ↓
	Display has '–' sign (–AUTO, –PER, or –MOV)?  NOTE Wait 15–20 minutes, then check display. If '–' sign is still present continue with TS Chart .	YES: Go to TS Chart 12. NO: Continue ↓
9.3 Load GPS time into RT.	GPS time loads?	YES: End of Operational Check. NO: Replace RT.

(End of Operational Check for SARM; See TS Chart 13 for Check if having trouble with transmitting / receiving data using data device.)

**6.3. TROUBLESHOOTING FLOWCHARTS.**

This paragraph provides the unit maintainer with two general use schematics (Short Range Single ASIP Radio Mount and Long Range Single ASIP Radio Mount) plus 13 Troubleshooting Charts. The unit maintainer is directed to one or more specific Troubleshooting Chart from the Operational Check. Use of Troubleshooting Charts prior to application of the Operational Check, represents poor use of unit maintainer time, can result in false pulls, and is strongly discouraged.

After application of the Operational Check and one or more Troubleshooting Charts, if required, the unit maintainer will perform the prescribed LRU replacement or repair. To ensure that the system is completely operational following such maintenance action, the unit maintainer again applies the complete Operational Check. If the system then passes all steps of the Operational Check, the system may be declared fully operational and returned to service.

6.3. TROUBLESHOOTING FLOWCHARTS. Continued

NOTE

- If the communications system includes a vehicular intercom VIC, begin troubleshooting with chapter 2.

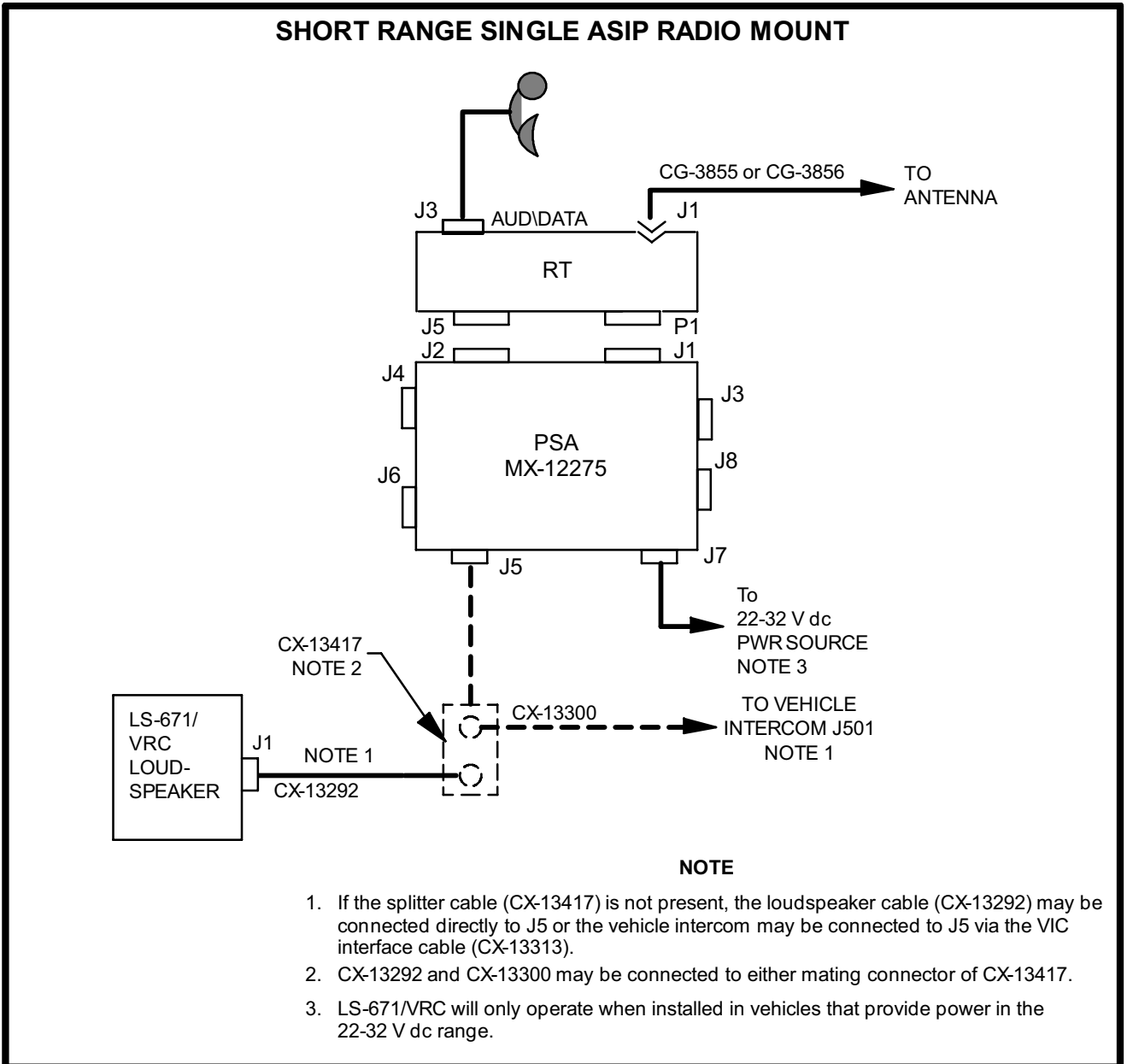





6.3. TROUBLESHOOTING FLOWCHARTS. Continued

CHART 1

PSA MX-12275 CB1 TRIPS WHEN SET TO "ON".  
(Sheet 1 of 4)

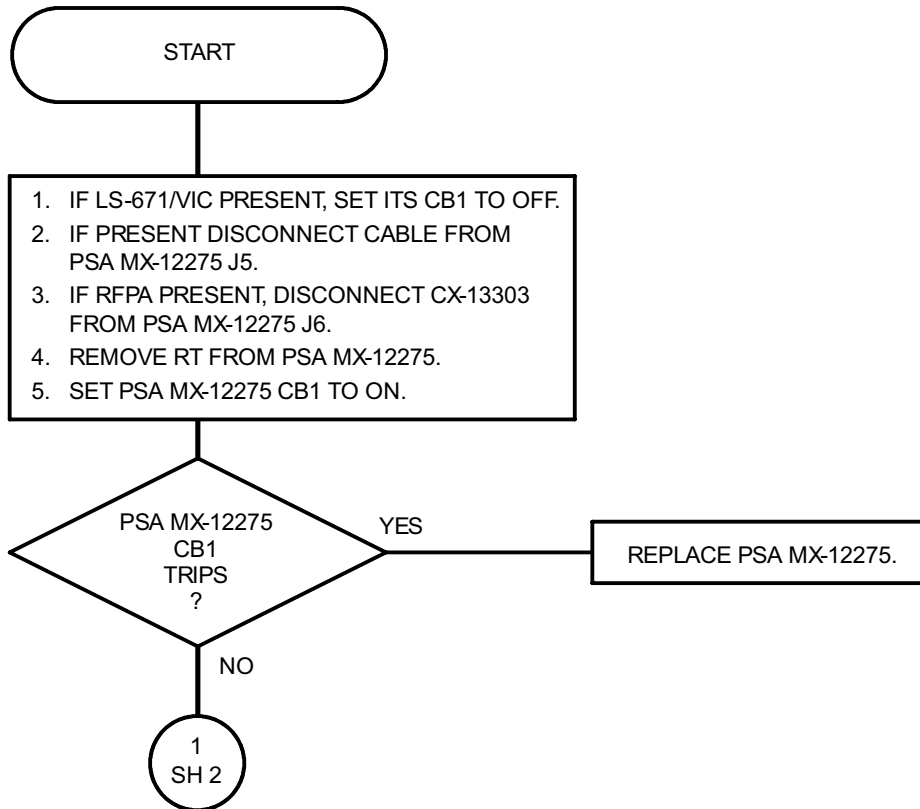

6.3. TROUBLESHOOTING FLOWCHARTS. Continued

CHART 1  
PSA MX-12275 CB1 TRIPS WHEN SET TO "ON".  
(Sheet 2 of 4)

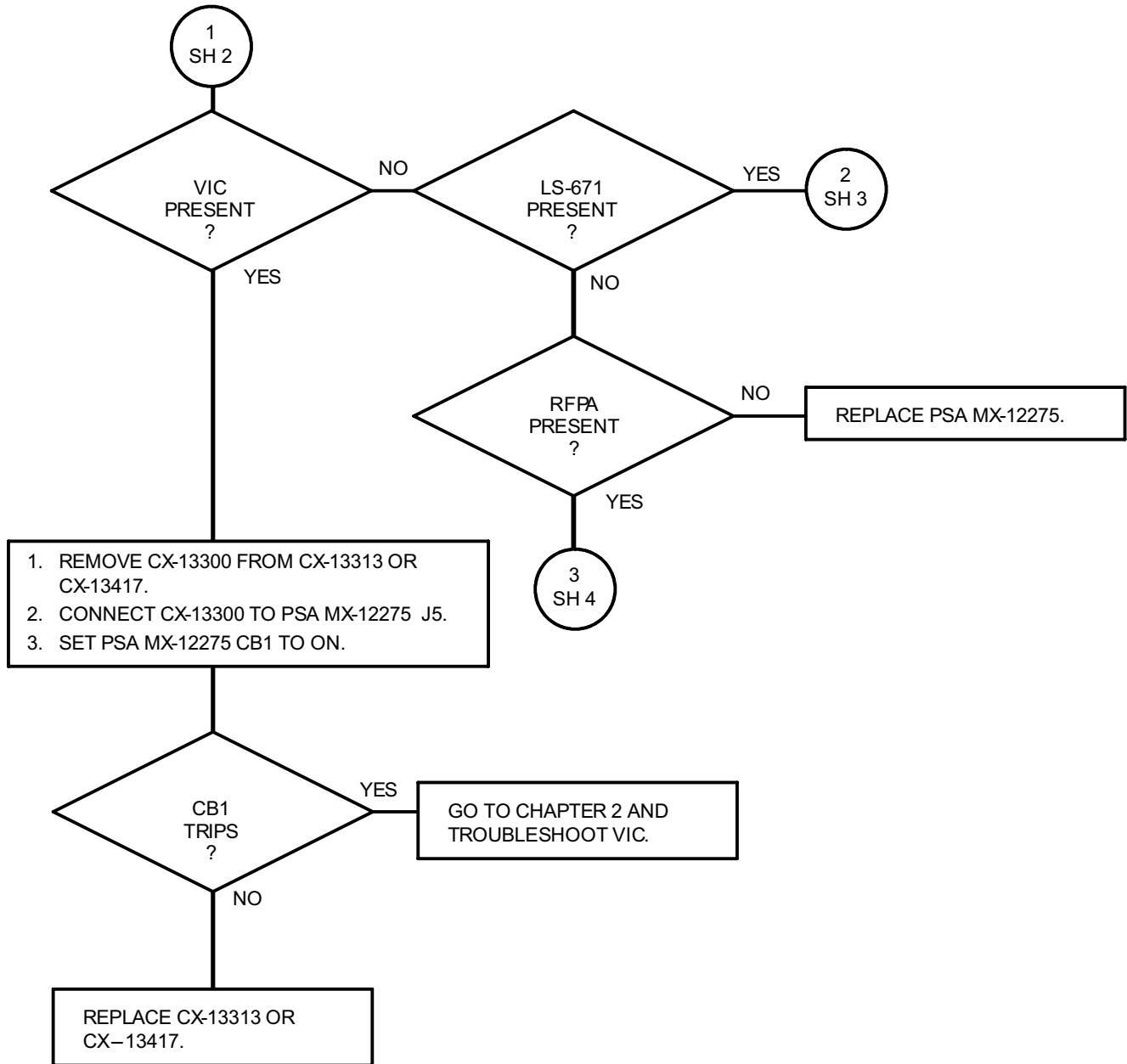

6.3. TROUBLESHOOTING FLOWCHARTS. Continued

CHART 1

PSA MX-12275 CB1 TRIPS WHEN SET TO "ON".  
(Sheet 3 of 4)

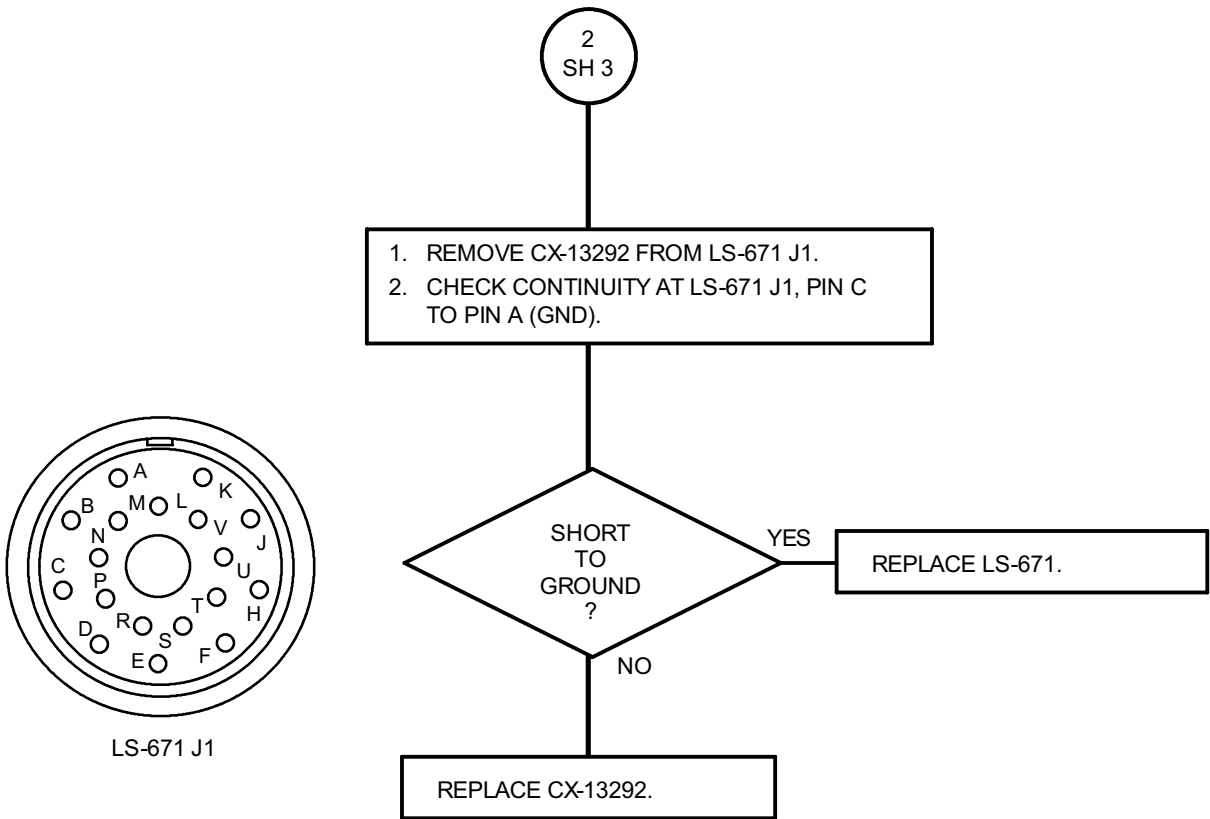

6.3. TROUBLESHOOTING FLOWCHARTS. Continued

CHART 1

PSA MX-12275 CB1 TRIPS WHEN SET TO "ON".  
(Sheet 4 of 4)

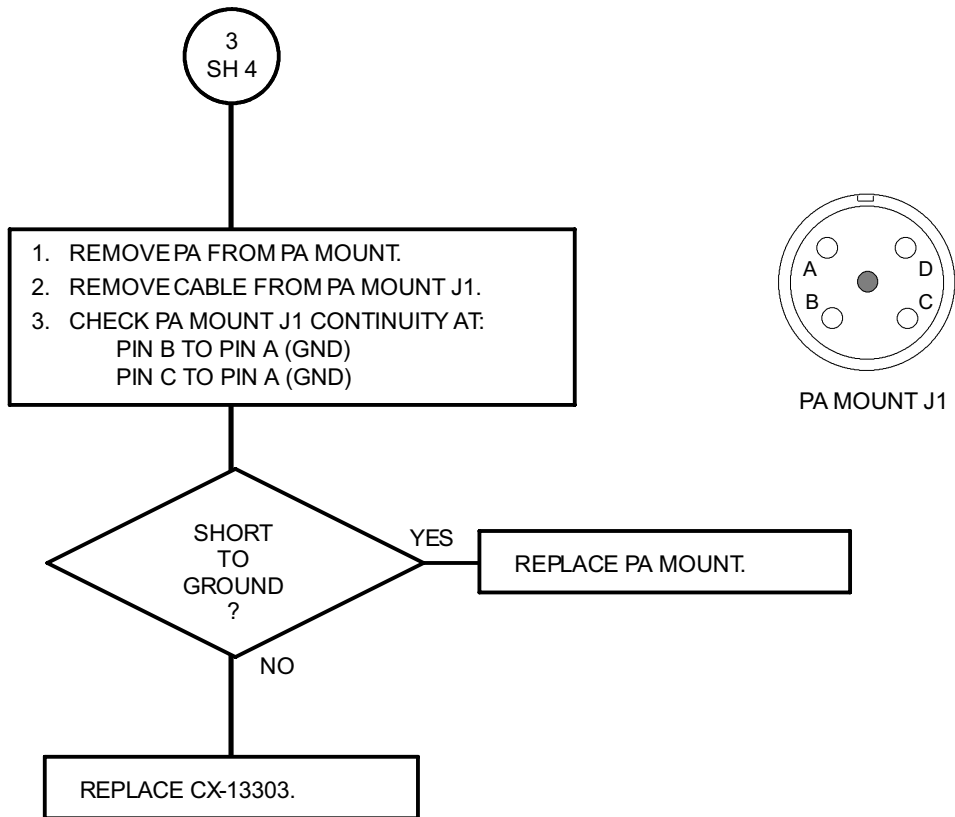

6.3. TROUBLESHOOTING FLOWCHARTS. Continued

CHART 2

LS-671 DS1 NOT LIT WHEN CB1 IS SET TO "ON".  
(Sheet 1 of 2)

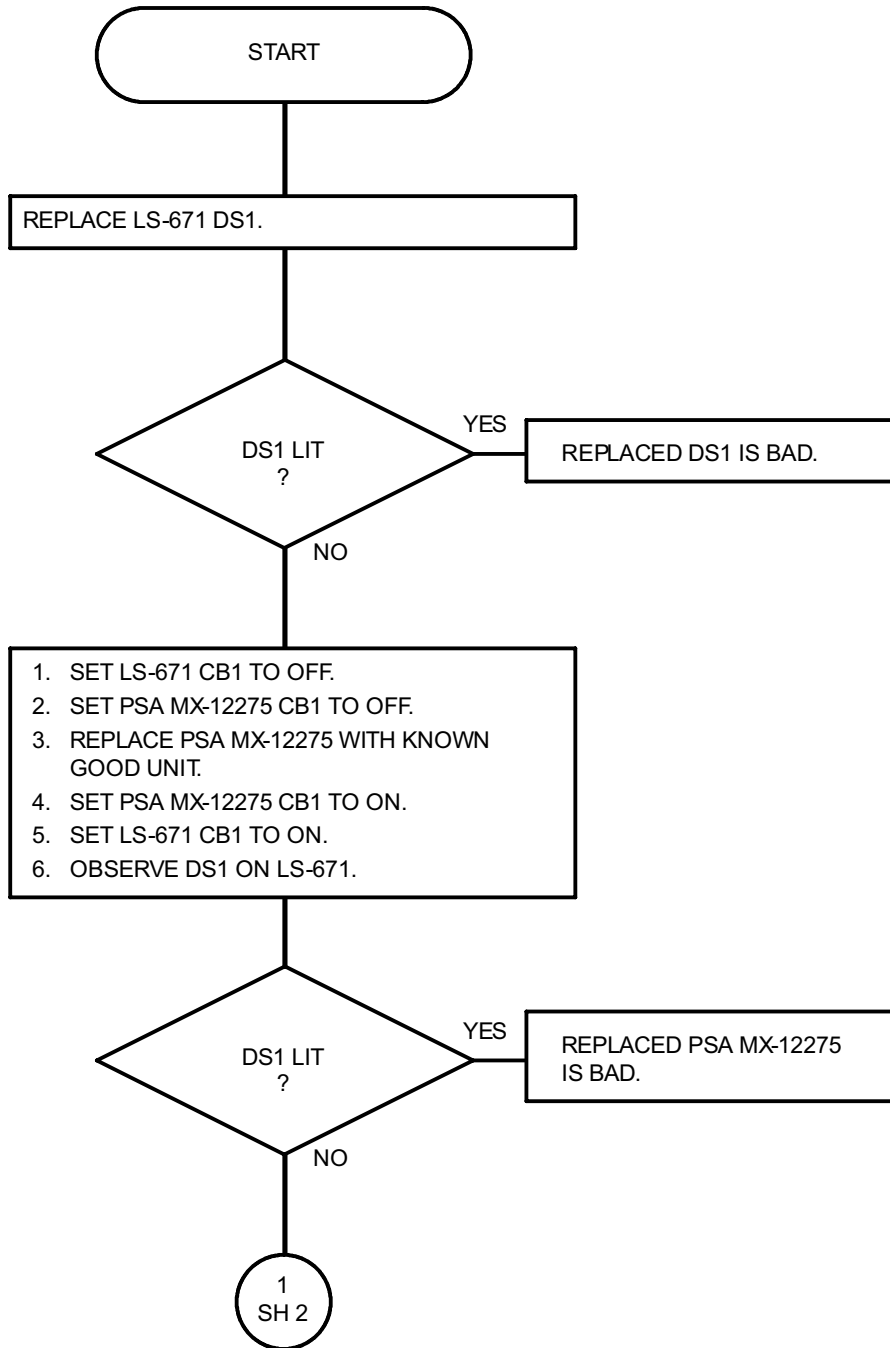

NOTE:

Make sure LS-671 DS1 is set full CCW.

6.3. TROUBLESHOOTING FLOWCHARTS. Continued

CHART 2

LS-671 DS1 NOT LIT WHEN CB1 IS SET TO 'ON'.  
(Sheet 2 of 2)

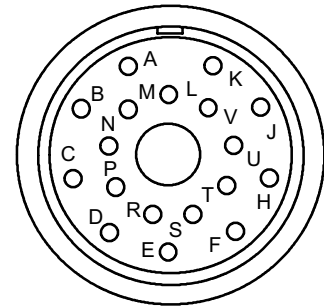
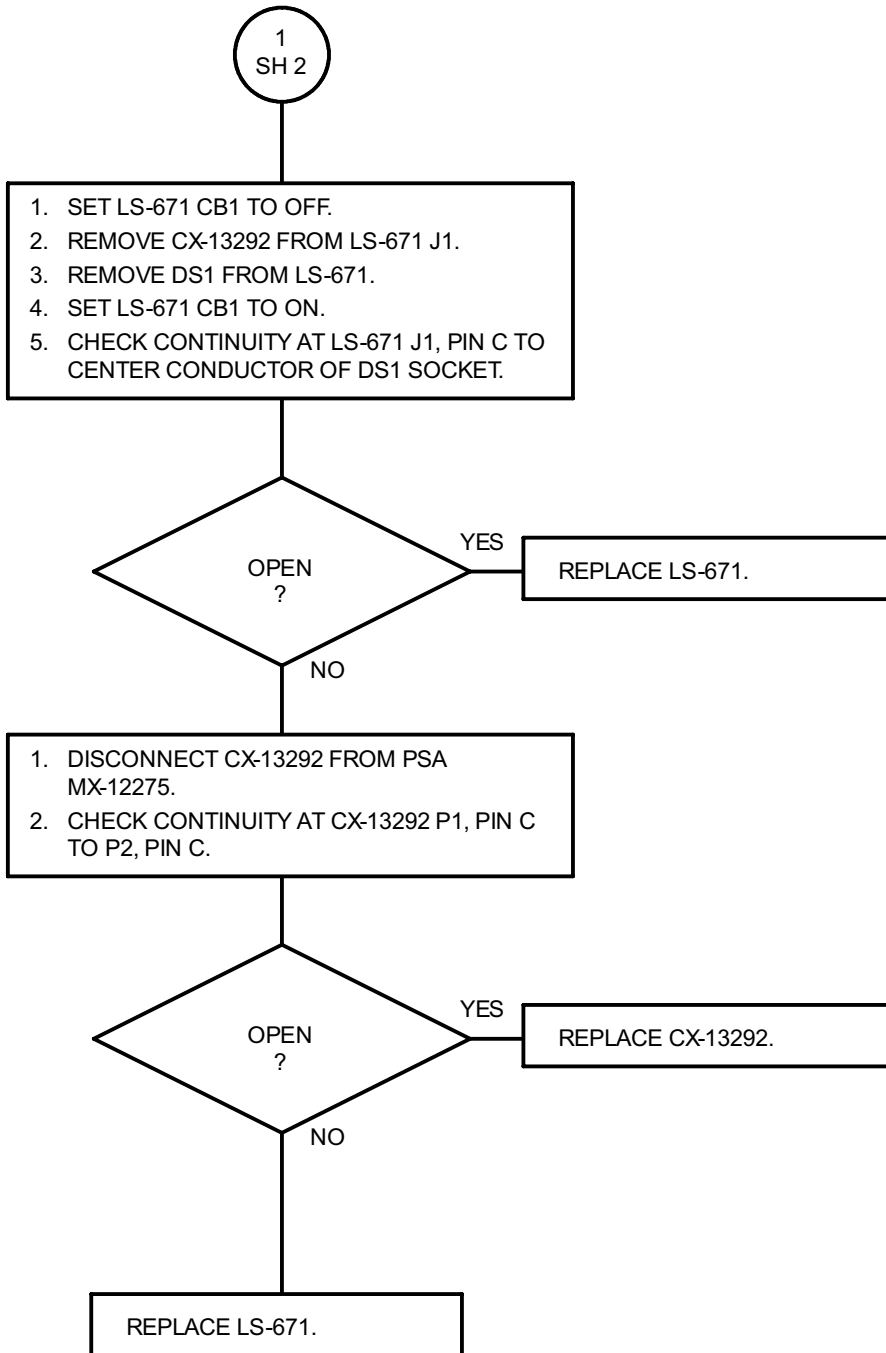

LS-671 J1

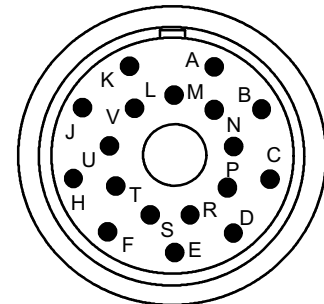

CX-13292 P1, P2

6.3. TROUBLESHOOTING FLOWCHARTS. Continued

CHART 3

RT DISPLAY DOES NOT LIGHT.

(Sheet 1 of 1)

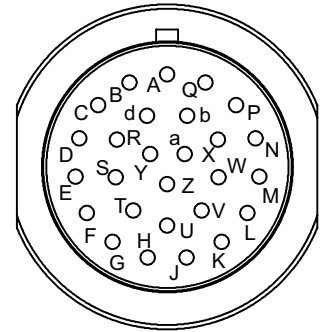
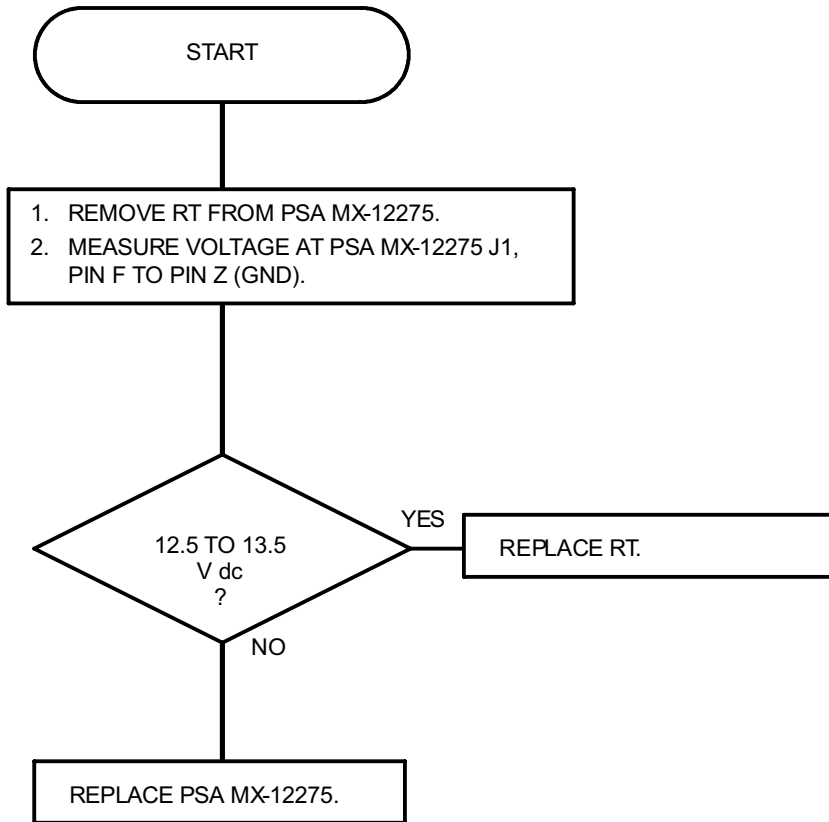

PSA MX-12275 J1

6.3. TROUBLESHOOTING FLOWCHARTS. Continued

CHART 4

NO BEEPS HEARD AT HANDSET AND/OR LOUDSPEAKER WHEN RT IS IN SELF-TEST.  
(Sheet 1 of 3)

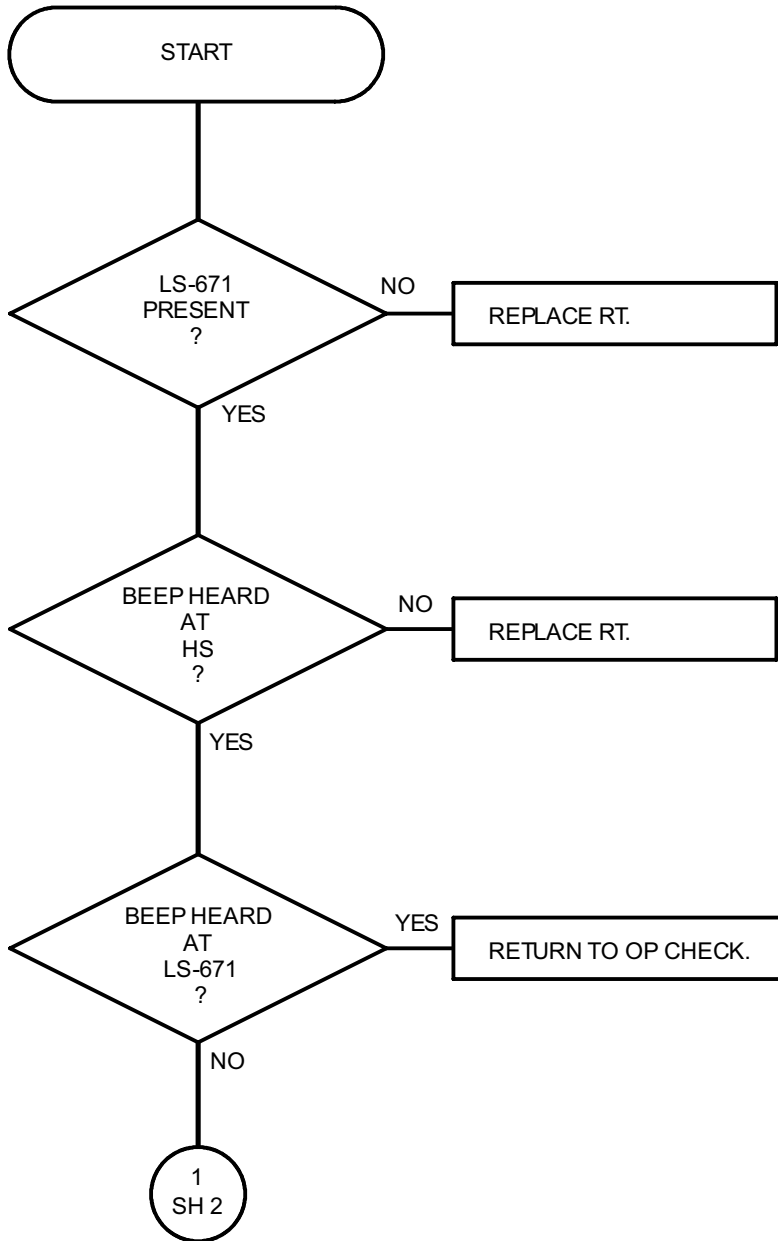

**NOTE:**

Make sure volume switches at RT and LS-671 are set to mid-range, CX-13314 cable is disconnected, and handset is connected to RT AUD/DATA connector.



6.3. TROUBLESHOOTING FLOWCHARTS. Continued

CHART 4

NO BEEPS HEARD AT HANDSET AND/OR LOUDSPEAKER WHEN RT IS IN SELF-TEST.  
(Sheet 2 of 3)

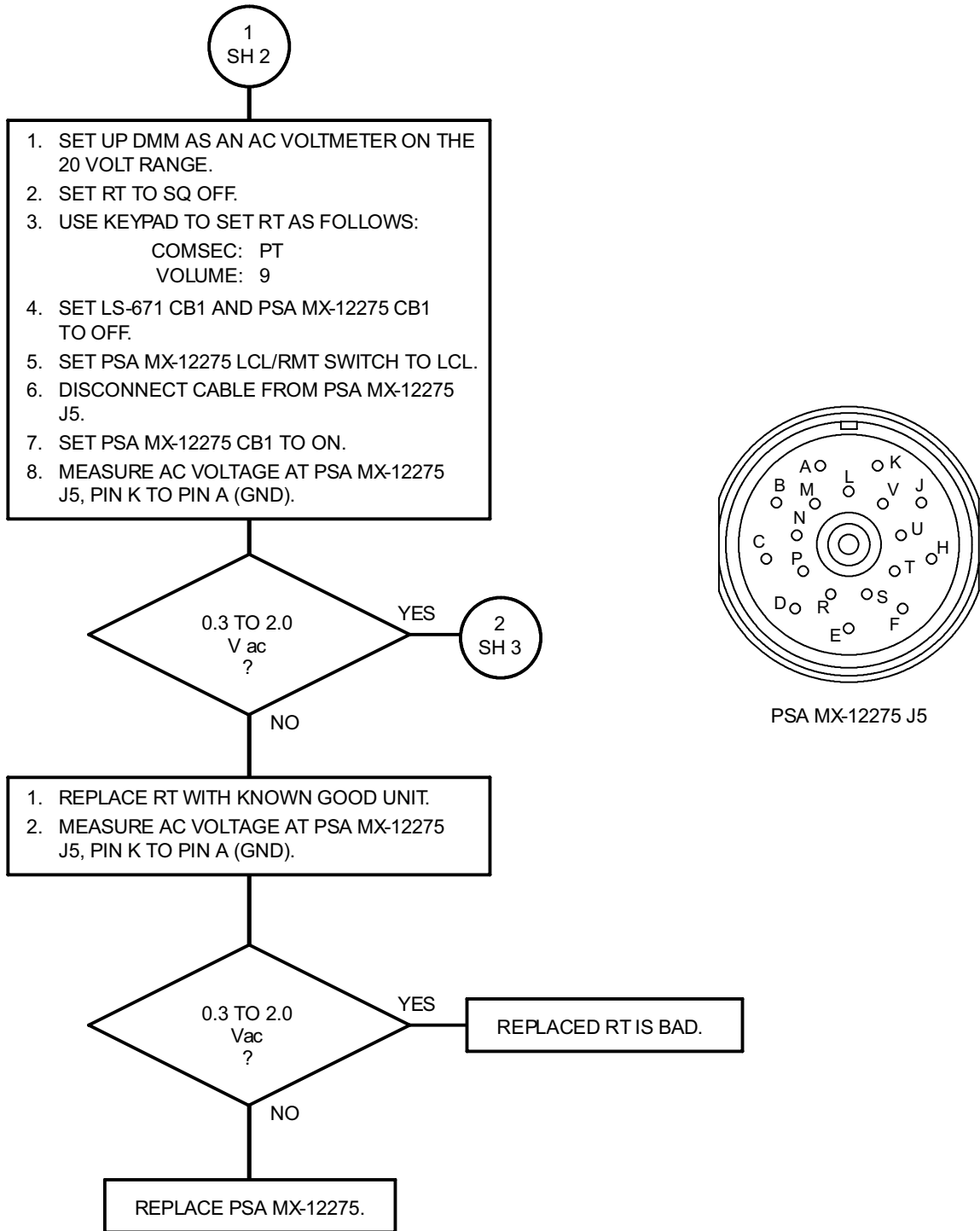

6.3. TROUBLESHOOTING FLOWCHARTS. Continued

CHART 4

NO BEEPS HEARD AT HANDSET AND/OR LOUDSPEAKER WHEN RT IS IN SELF-TEST.

(Sheet 3 of 3)

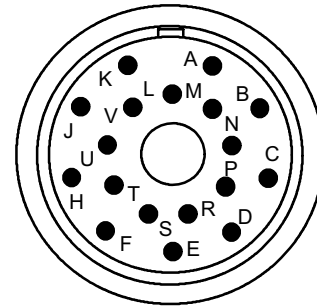
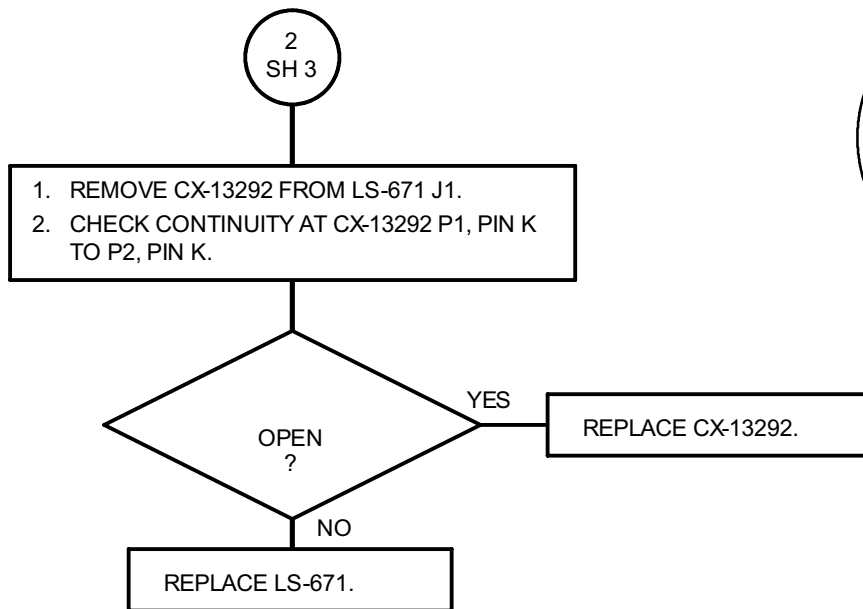

CX-13292 P1, P2

6.3. TROUBLESHOOTING FLOWCHARTS. Continued

CHART 5  
VARIABLE WILL NOT LOAD.  
(Sheet 1 of 1)

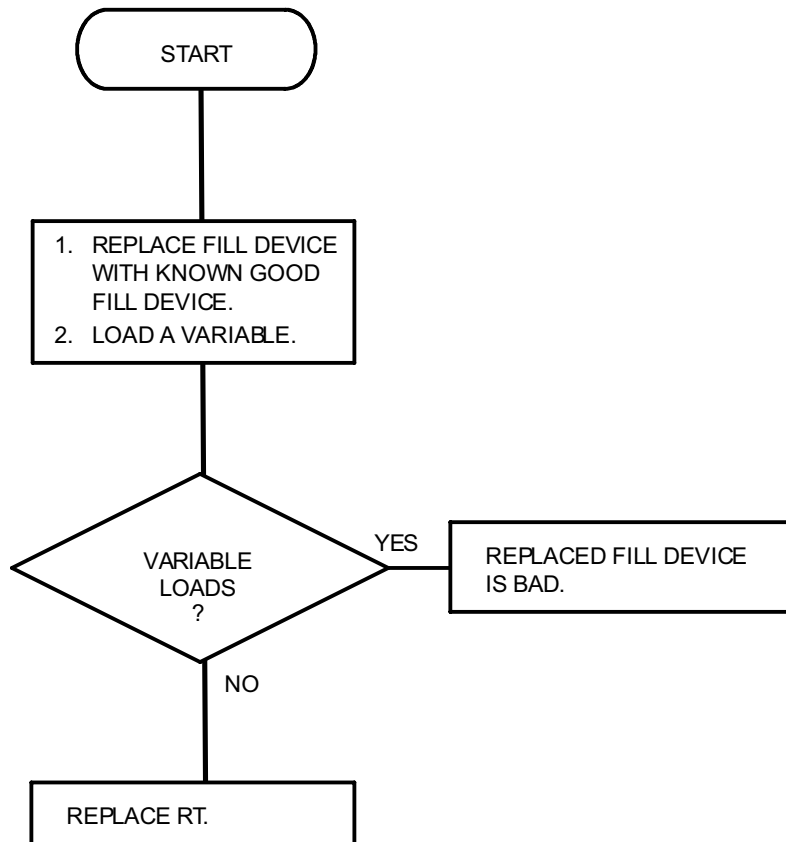

6.3. TROUBLESHOOTING FLOWCHARTS. Continued

Chart 6

FAILED FORWARD AND REVERSE POWER CHECK.  
(Sheet 1 of 3)

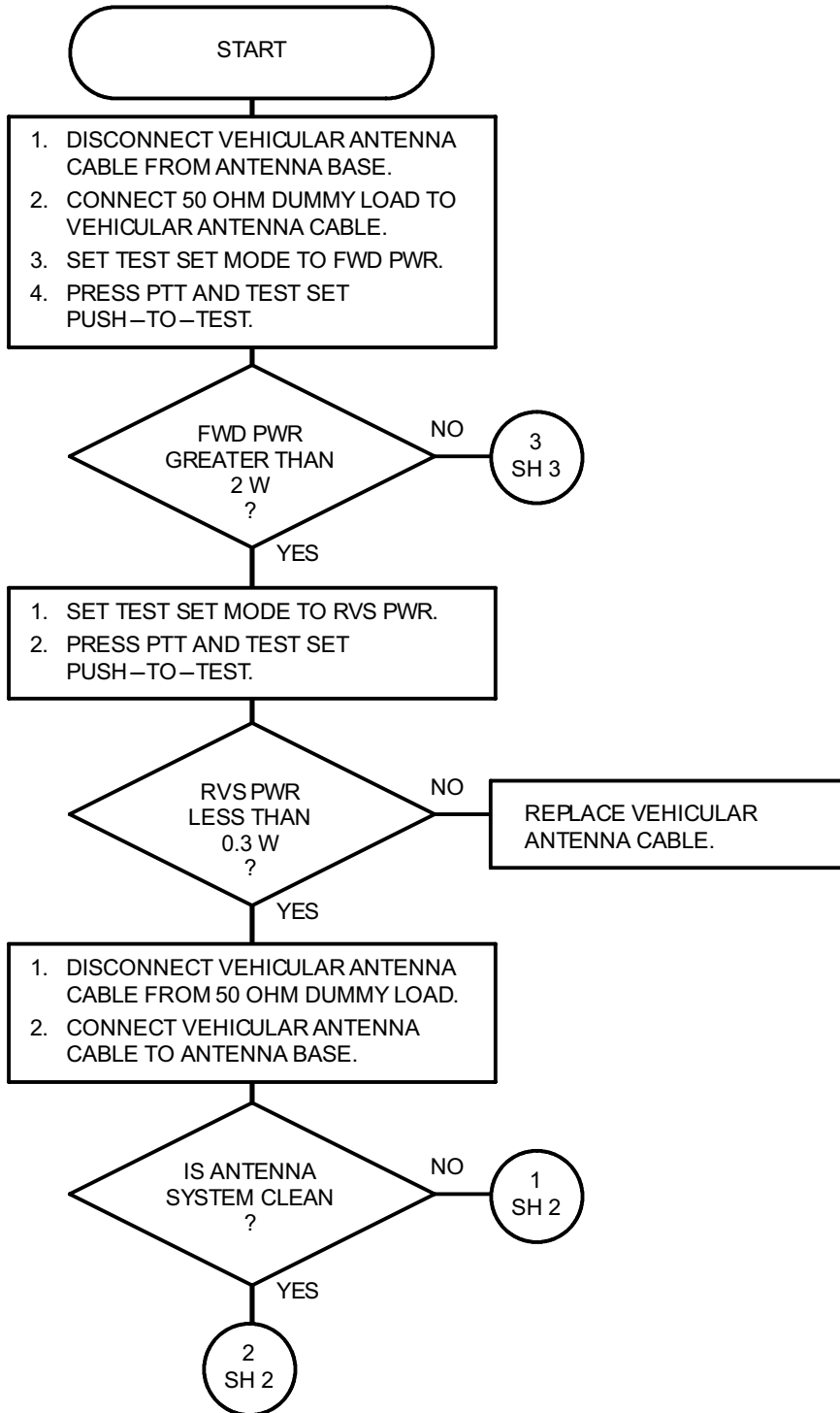

6.3. TROUBLESHOOTING FLOWCHARTS. Continued

Chart 6

FAILED FORWARD AND REVERSE POWER CHECK.

(Sheet 2 of 3)

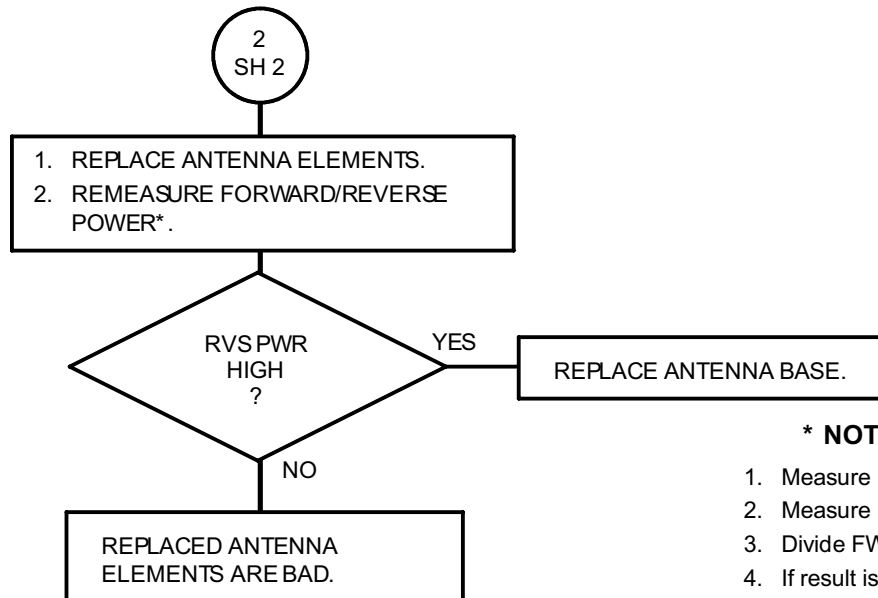
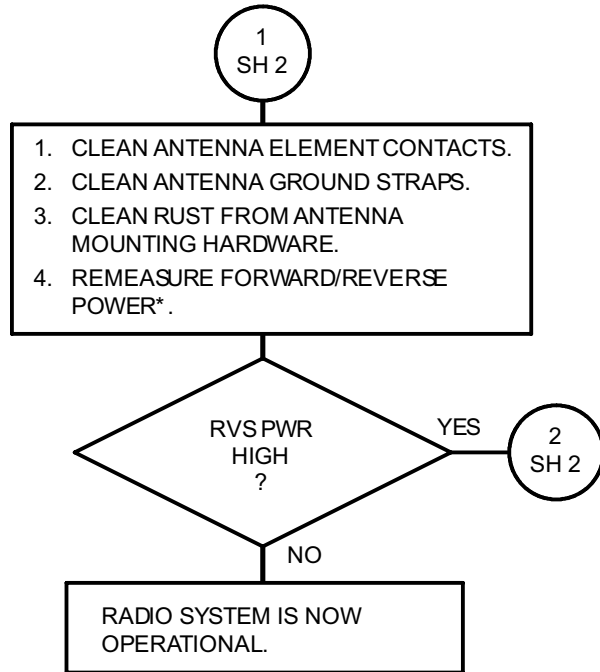

**\* NOTE, RVS PWR QUICK CHECK:**

1. Measure FWD PWR (e.g., 4.6 W).
2. Measure RVS PWR (e.g., 1.2 W).
3. Divide FWD PWR by RVS PWR (e.g., 4.6/1.2).
4. If result is 3.0\* or MORE, RVS PWR is normal.
5. If result is LESS THAN 3.0\*, RVS PWR is high, troubleshoot.
6. \* If radio is used for data transmission, a result of 4.0 or more is desired.

6.3. TROUBLESHOOTING FLOWCHARTS. Continued

Chart 6

FAILED FORWARD AND REVERSE POWER CHECK.  
(Sheet 3 of 3)

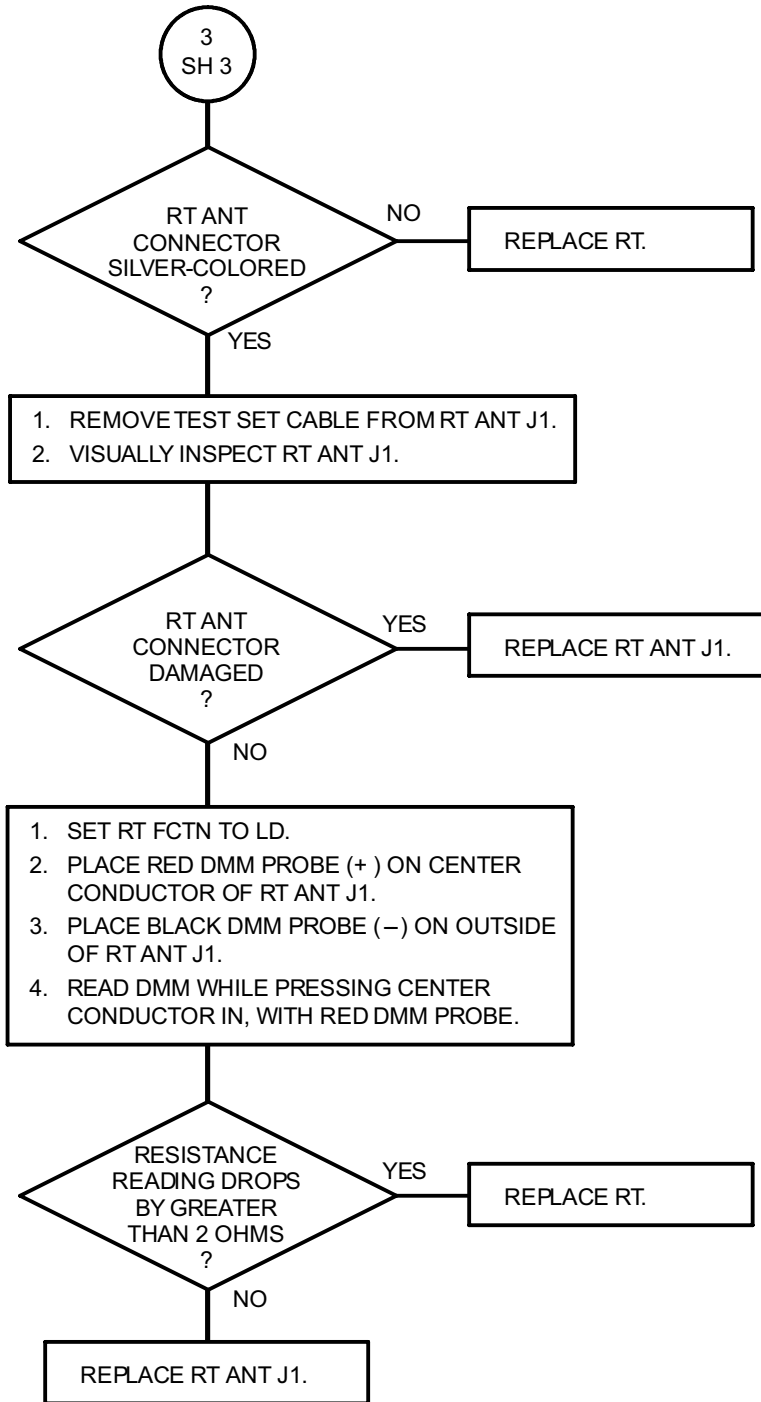

6.3. TROUBLESHOOTING FLOWCHARTS. Continued

Chart 7

FORWARD POWER INCORRECT THRU PA IN RF PWR HI.  
(Sheet 1 of 2)

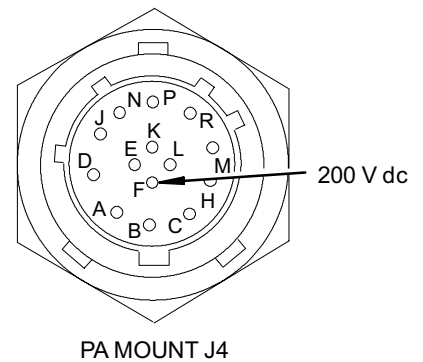
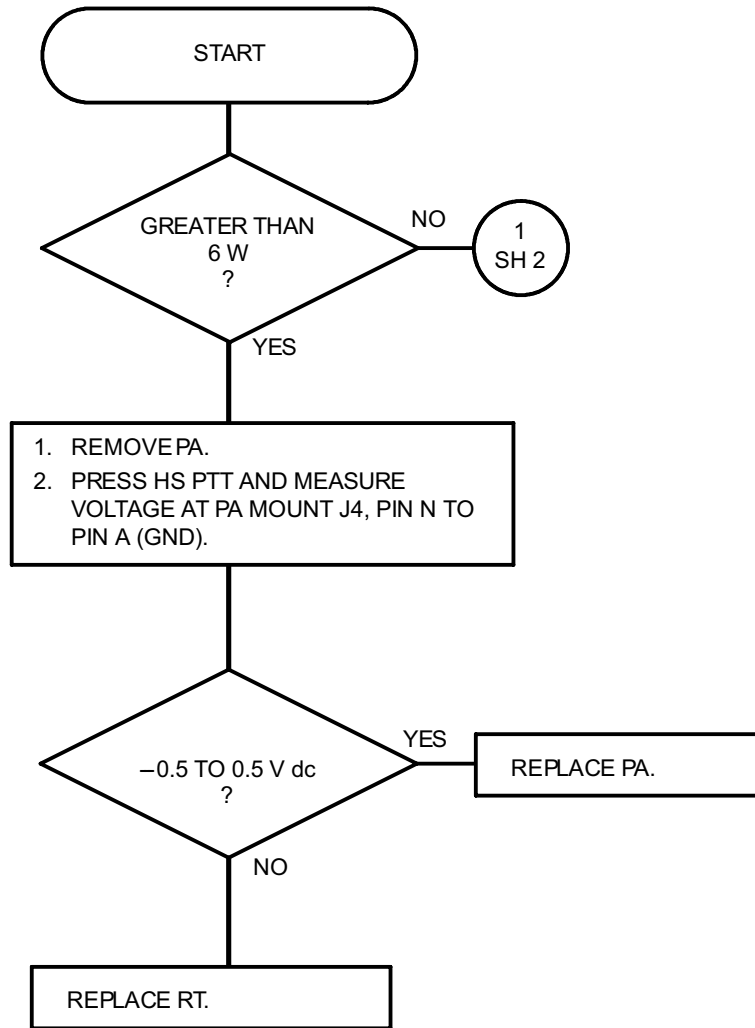

**WARNING**

Connector J4 of the PA mount has 200 V dc on pin F. Use extreme care in measuring voltages on PA mount connector J4.

6.3. TROUBLESHOOTING FLOWCHARTS. Continued

Chart 7

FORWARD POWER INCORRECT THRU PA IN RF PWR HI.  
(Sheet 2 of 2)

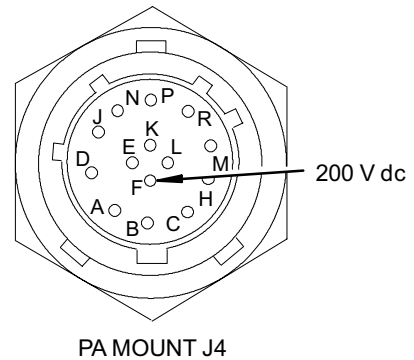
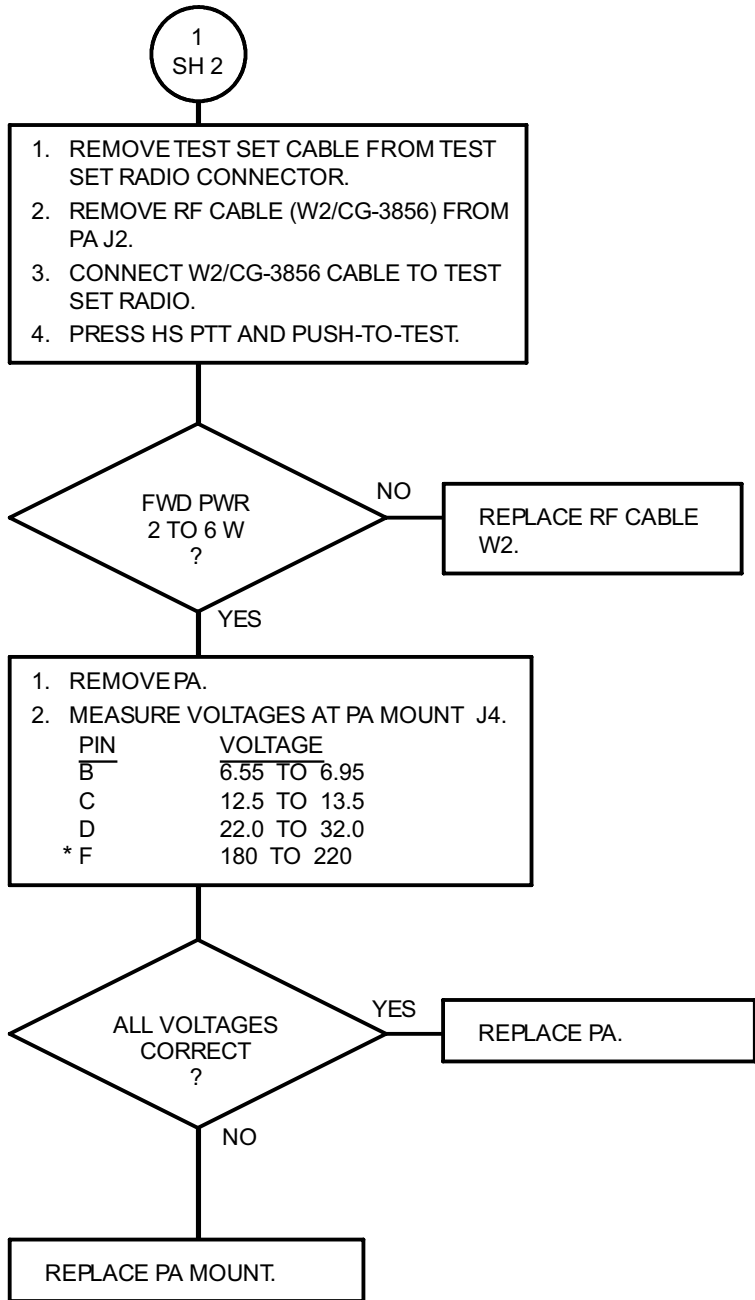

\* **WARNING**  
Connector J4 of the PA mount has 200 V dc on pin F. Use extreme care in measuring voltages on PA mount connector J4.



6.3. TROUBLESHOOTING FLOWCHARTS. Continued

Chart 8

LESS THAN 30 W FORWARD POWER OUT OF PA FROM 30 TO 43 MHz.

(Sheet 1 of 3)

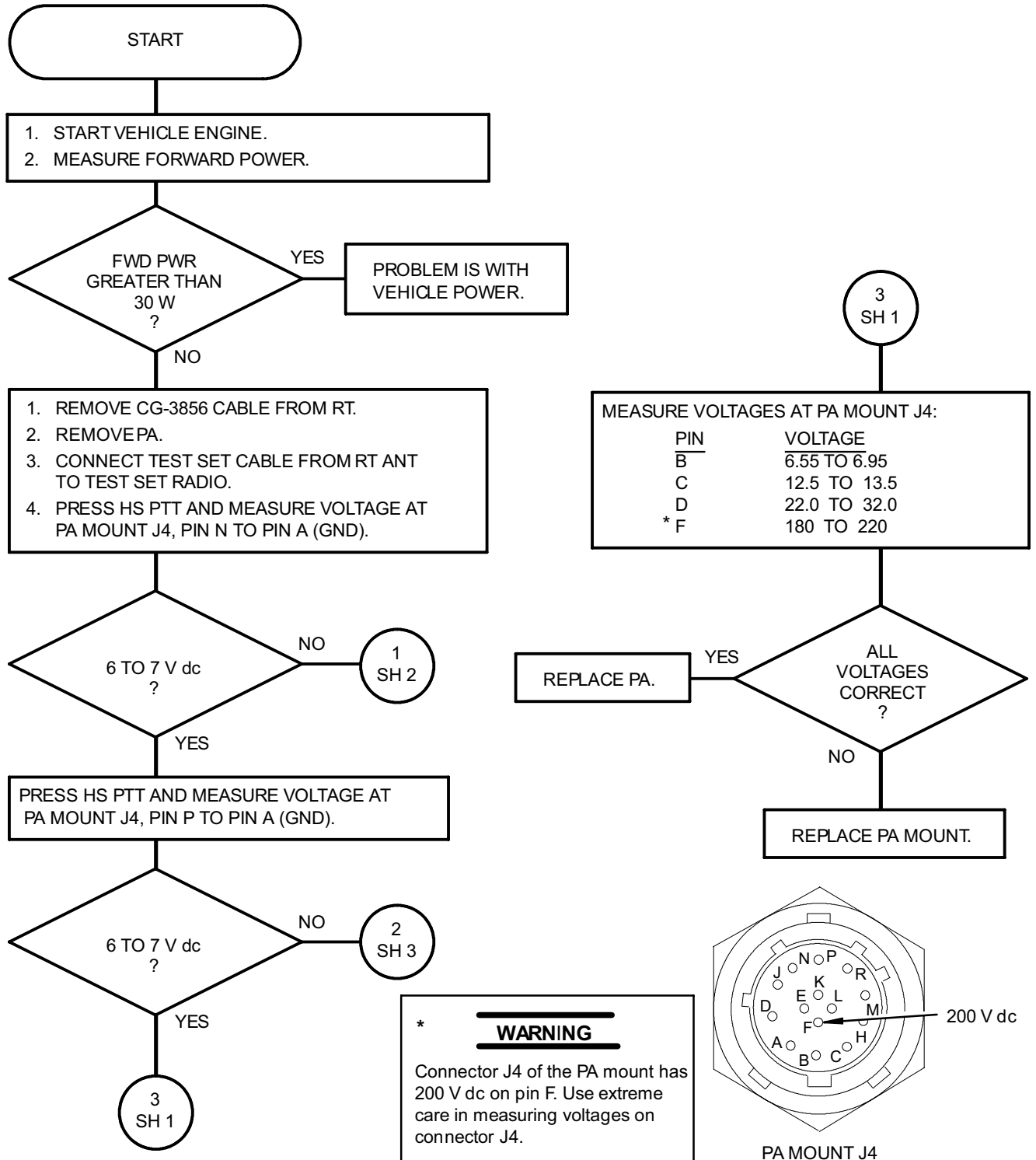

6.3. TROUBLESHOOTING FLOWCHARTS. Continued

Chart 8

LESS THAN 30 W FORWARD POWER OUT OF PA FROM 30 TO 43 MHZ.  
(Sheet 2 of 3)

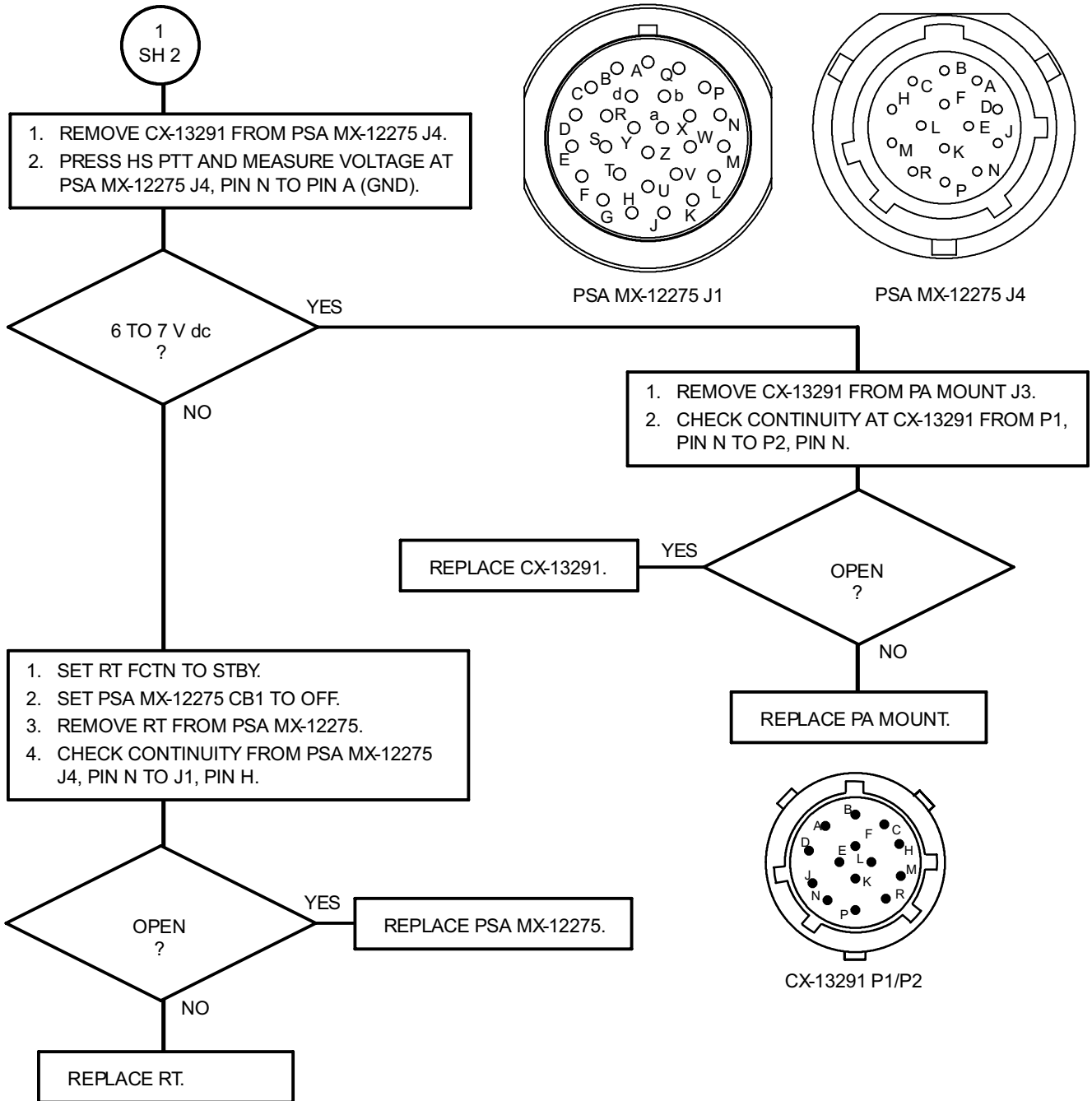

6.3. TROUBLESHOOTING FLOWCHARTS. Continued

Chart 8

LESS THAN 30 W FORWARD POWER OUT OF PA FROM 30 TO 43 MHZ.  
(Sheet 3 of 3)

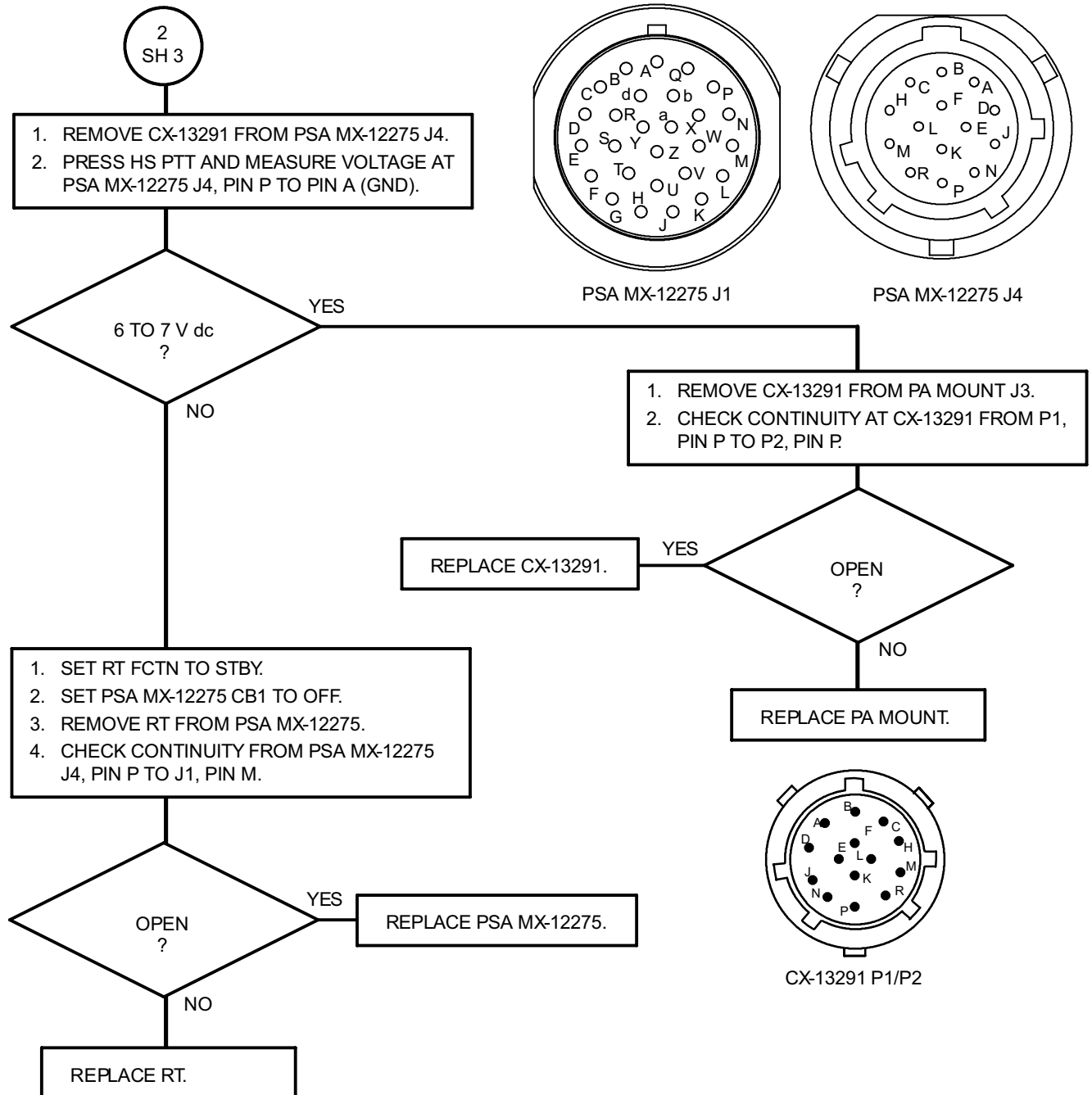

6.3. TROUBLESHOOTING FLOWCHARTS. Continued

Chart 9

LESS THAN 30 W FORWARD POWER OUT OF PA  
FROM EITHER 43 TO 61.4 MHZ OR 61.4 TO 88 MHZ.

(Sheet 1 of 2)

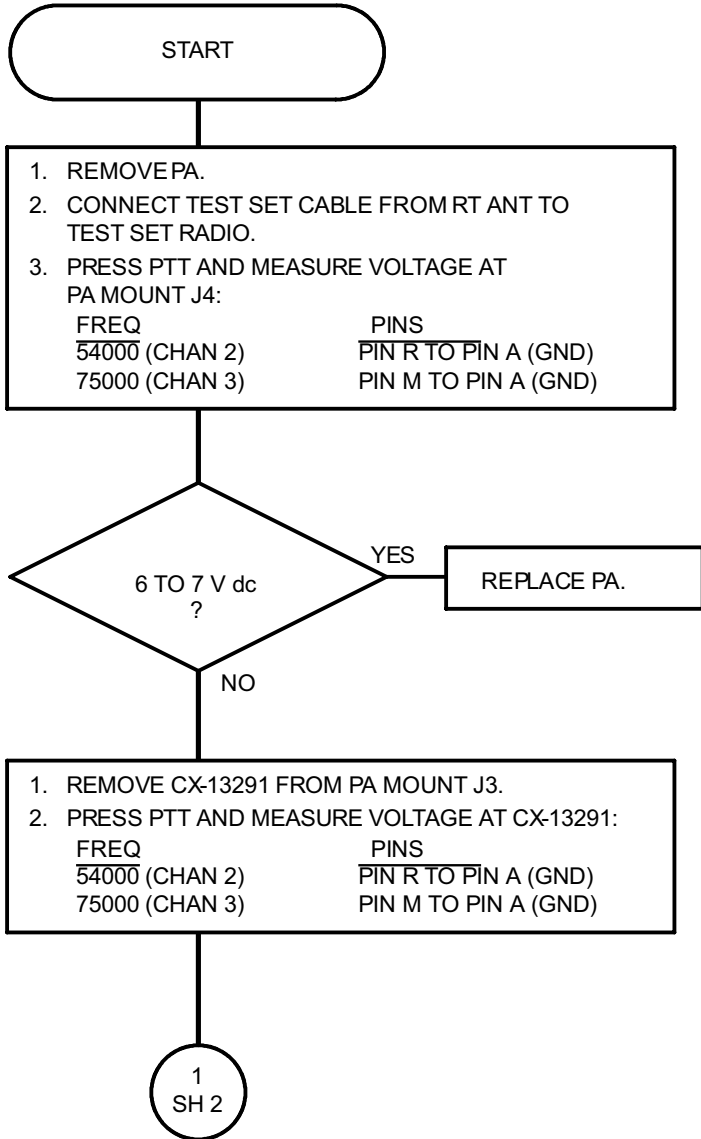

**WARNING**

Connector J4 of the PA mount has 200 V dc on pin F. Use extreme care in measuring voltages on connector J4.

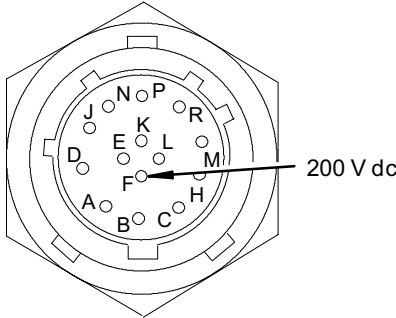

PA MOUNT J4

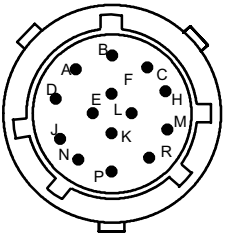

CX-13291 P1/P2

6.3. TROUBLESHOOTING FLOWCHARTS. Continued

Chart 9

LESS THAN 30 W FORWARD POWER OUT OF PA  
FROM EITHER 43 TO 61.4 MHZ OR 61.4 TO 88 MHZ.

(Sheet 2 of 2)

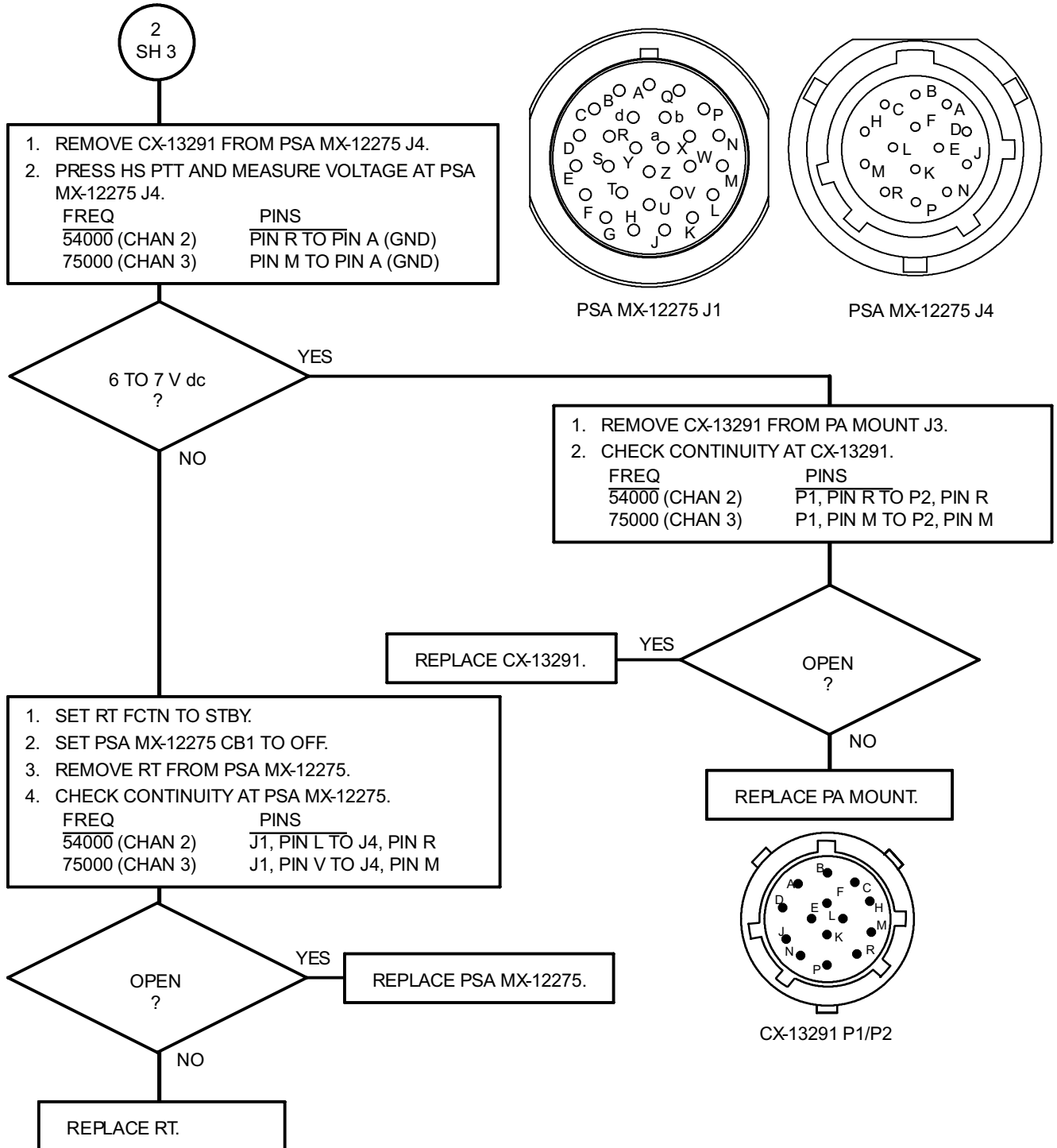

6.3. TROUBLESHOOTING FLOWCHARTS. Continued

Chart 10

RT SIG DISPLAY INCORRECT WITH RT RF PWR SET TO <sup>a</sup>PA°.

(Sheet 1 of 2)

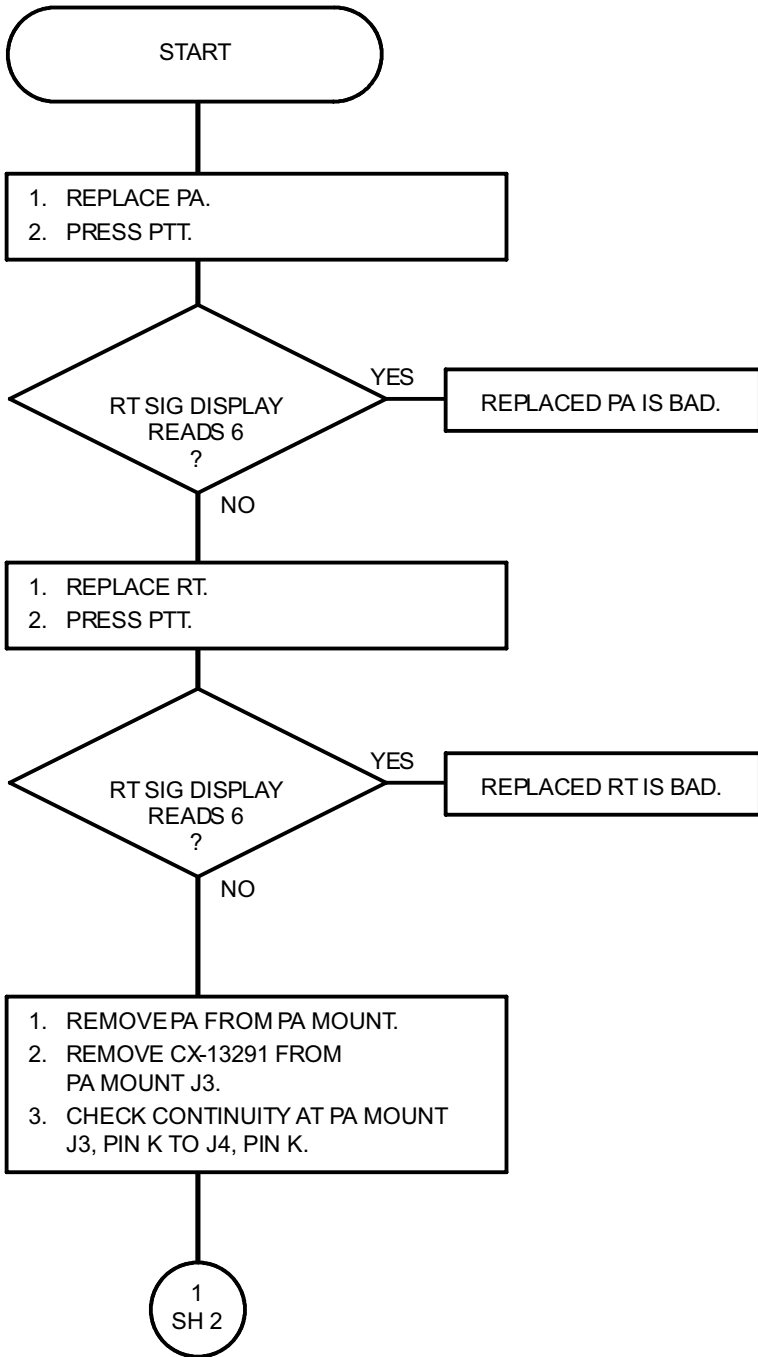

**WARNING**

Connector J4 of the PA mount has 200 V dc on pin F. Use extreme care in measuring voltages on connector J4.

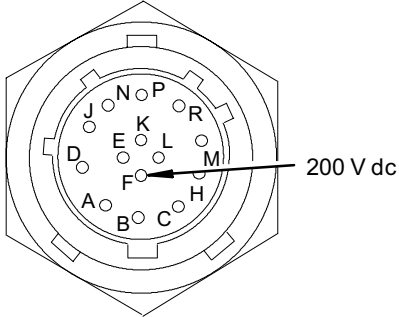

PA MOUNT J4

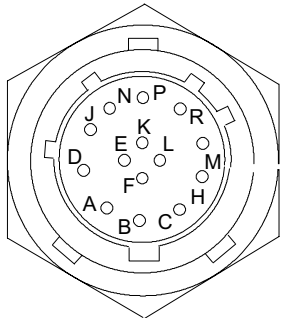

PA MOUNT J3

6.3. TROUBLESHOOTING FLOWCHARTS. Continued

Chart 10

RT SIG DISPLAY INCORRECT WITH RT RF PWR SET TO <sup>a</sup>PA<sup>o</sup>.

(Sheet 2 of 2)

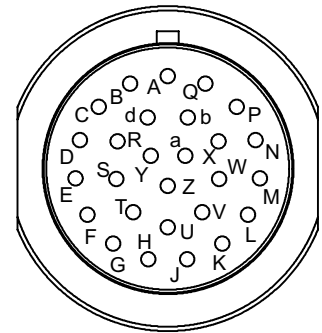
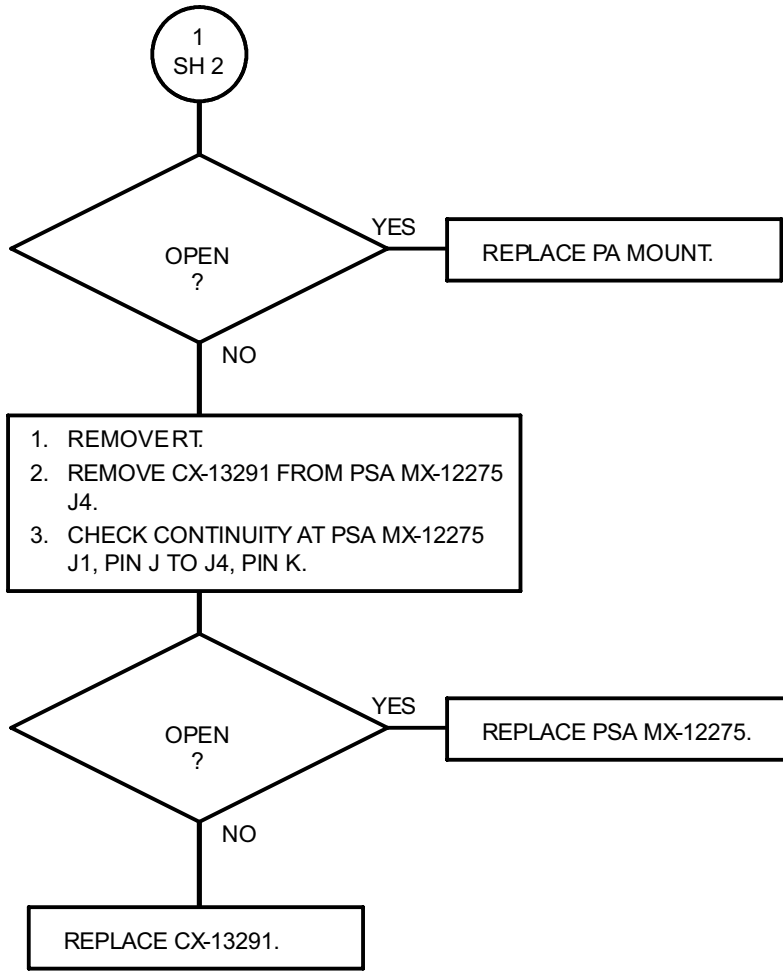

PSA MX-12275 J1

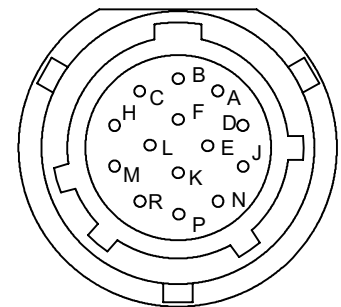

PSA MX-12275 J4

6.3. TROUBLESHOOTING FLOWCHARTS. Continued

CHART 11  
NO SIDETONE HEARD AT THE LS-671.  
(Sheet 1 of 2)

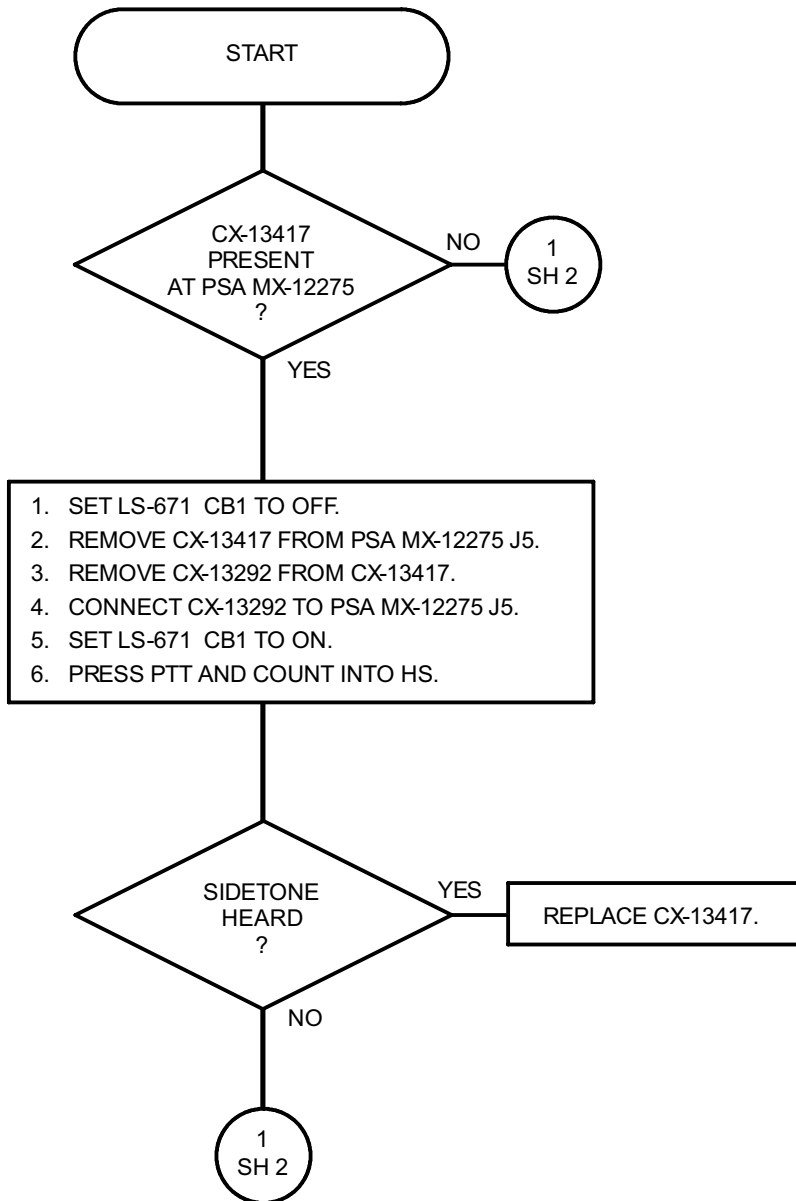



6.3. TROUBLESHOOTING FLOWCHARTS. Continued

CHART 11

NO SIDETONE HEARD AT THE LS-671.

(Sheet 2 of 2)

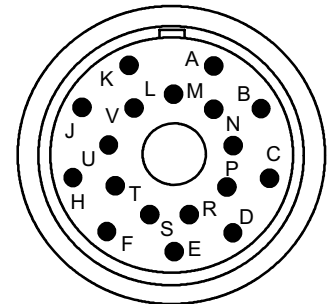
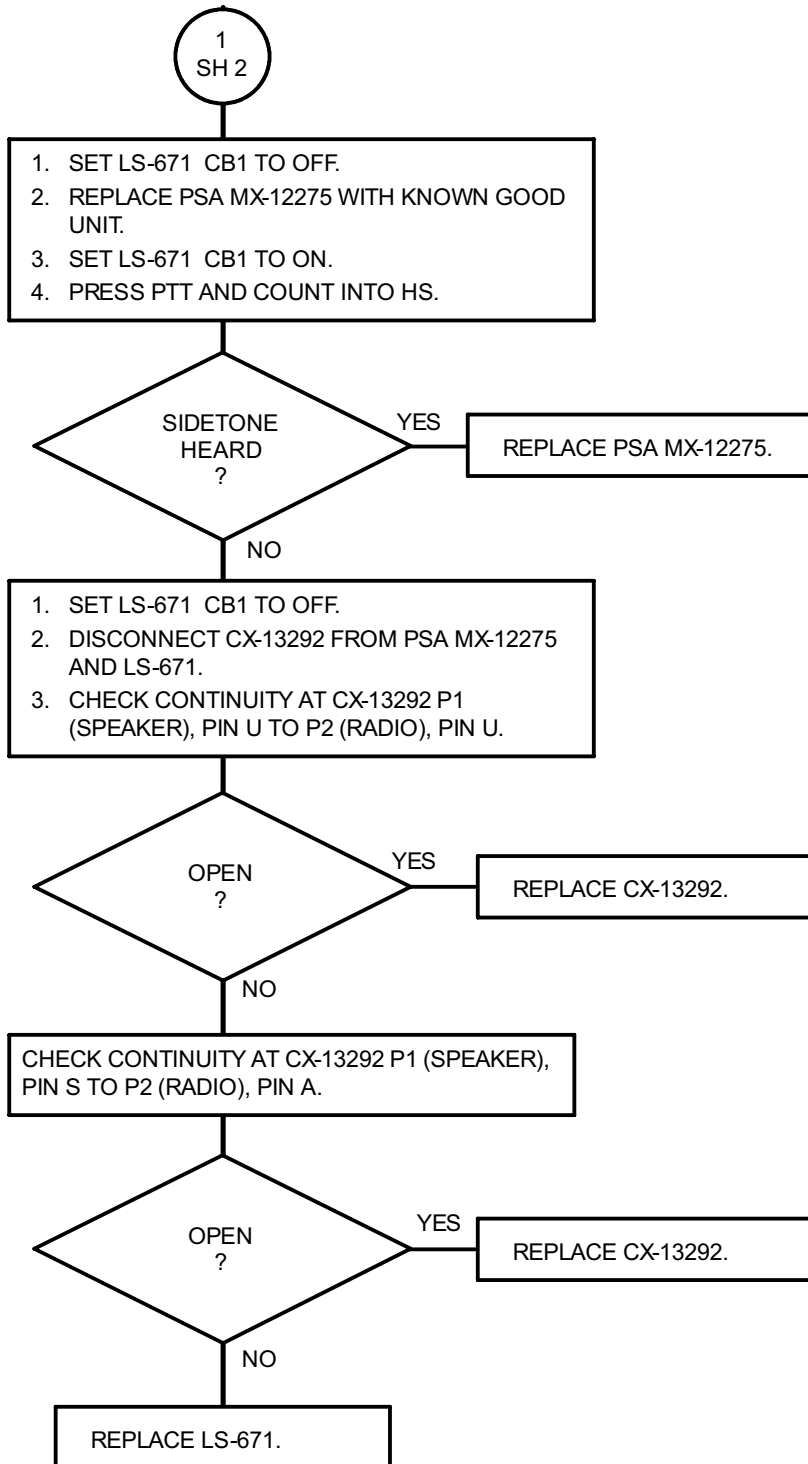

CX-13292 P1, P2

6.3. TROUBLESHOOTING FLOWCHARTS. Continued

CHART 12  
RADIO WITH EGR DISPLAYS –AUTO, –PER, OR –MOV.  
(Sheet 1 of 1)

**NOTE:**

If 20 minutes has elapsed and '–' is still displayed continue with TS Flowchart.

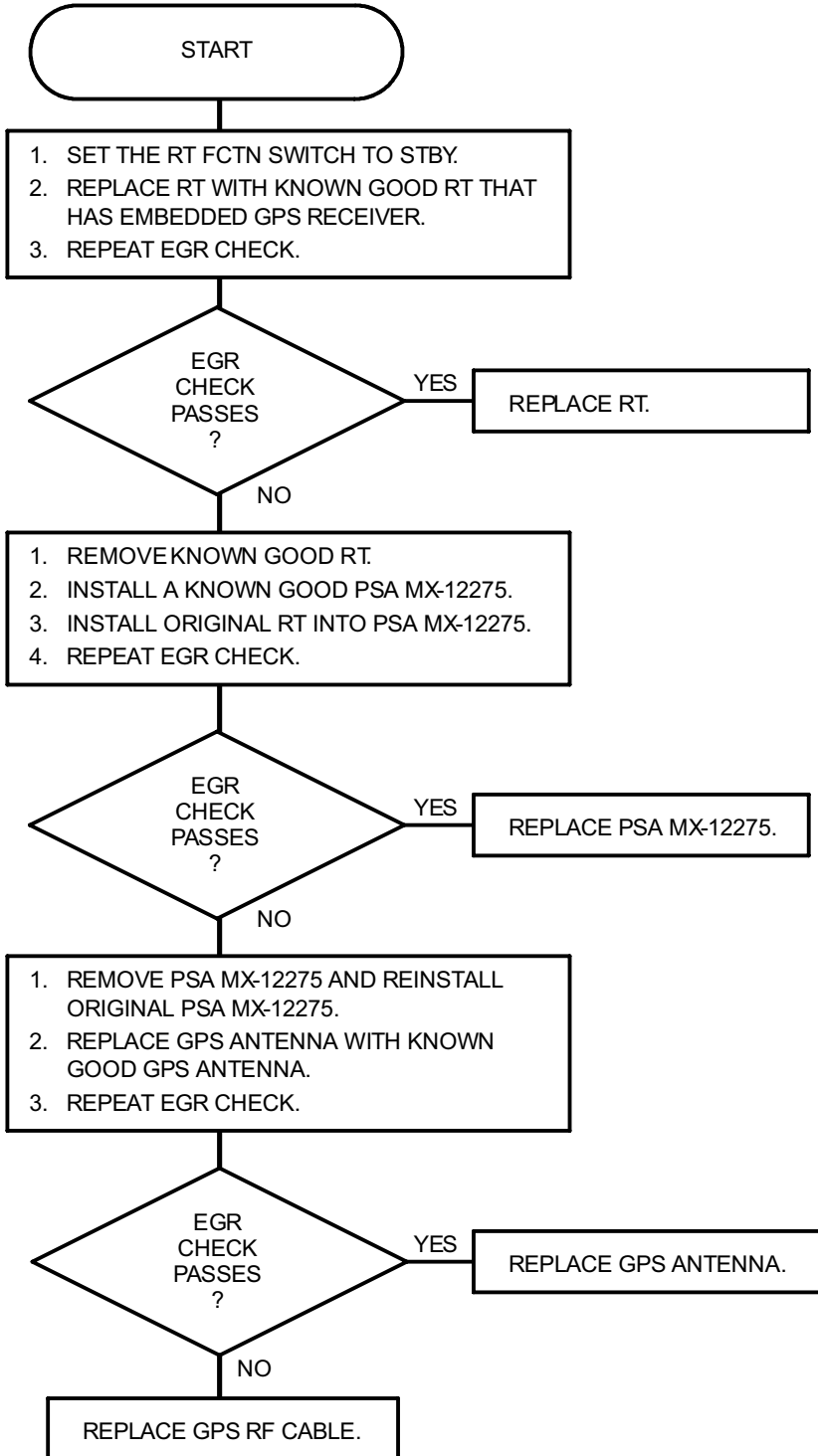

6.3. TROUBLESHOOTING FLOWCHARTS. Continued

CHART 13

RADIO WILL NOT OPERATE WITH DIGITAL DEVICES.

(Sheet 1 of 2)

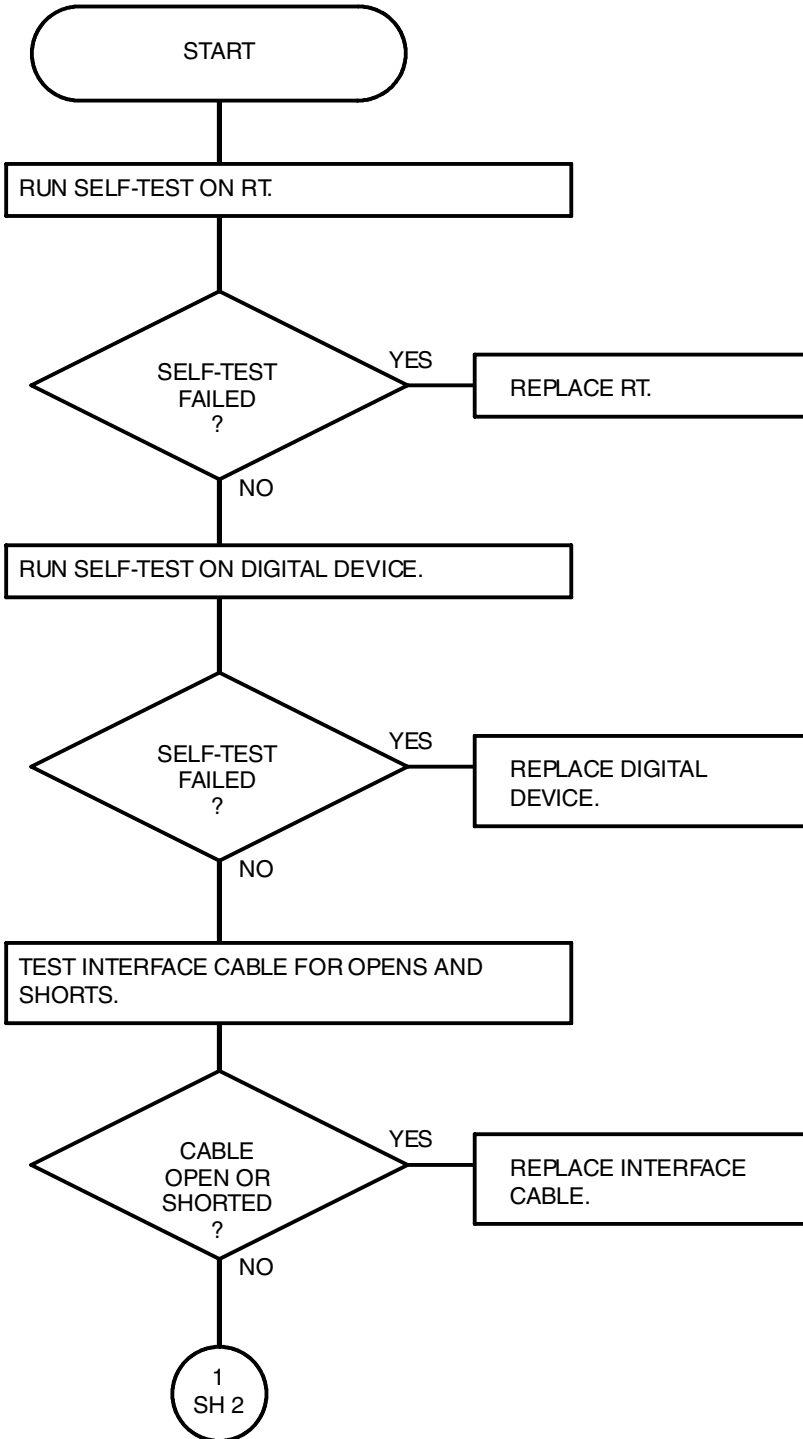

6.3. TROUBLESHOOTING FLOWCHARTS. Continued

CHART 13

RADIO WILL NOT OPERATE WITH DIGITAL DEVICES.

(Sheet 2 of 2)

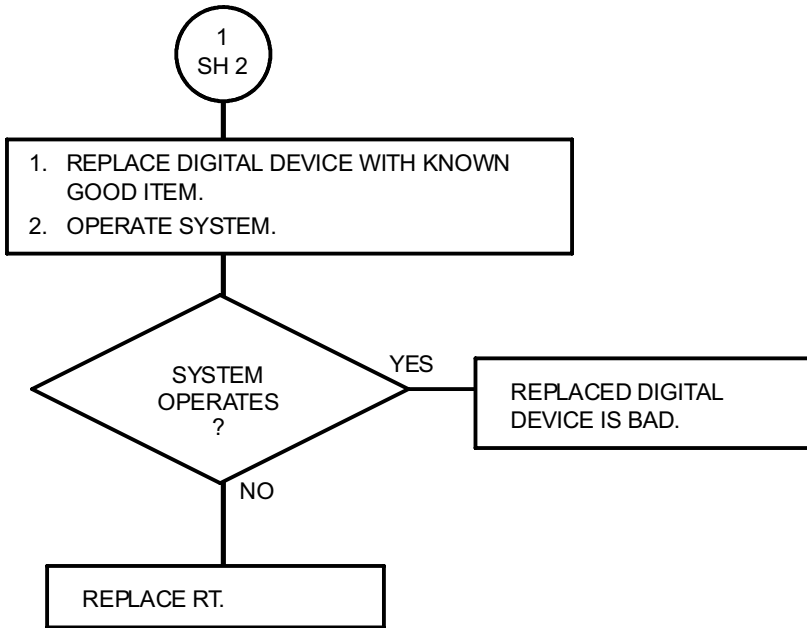

**NOTE:**

If a digital device is not available, replace the RT. If the system operates then the RT is bad.

## APPENDIX A

### REFERENCES

**A.1. SCOPE.** This appendix lists all forms, field manuals, technical manuals, and miscellaneous publication references in this manual.

#### A.2. FORMS.

DA Form 2028	Recommended Changes to Publications and Blank Forms.
DD 361	Discrepancy in Shipment Report (DISREP).
SF 364	Report of Discrepancy (TDR).
SF 368	Product Quality Deficiency Report (ROD).

#### A.3. FIELD MANUALS.

FM 4-25.11	Artificial Respiration.
------------	-------------------------

#### A.4. TECHNICAL MANUALS.

TM 11-5820-890-10-6	Department of the Army Technical Manual: SINCGARS ICOM Ground Radio Operator's Pocket Guide
TM 11-5820-890-10-7	Department of the Army Technical Manual: SINCGARS ICOM Ground Radio Net Control Station (NCS) Pocket Guide
TM 11-5820-890-10-8	Department of the Army Technical Manual: Operator's Manual SINCGARS Ground Combat Net Radio, ICOM
TM 11-5820-890-20-2	Department of the Army Technical Manual (Unit Maintenance Manual, Ground ICOM Radio Sets: AN/PRC-119A/D/F, AN/VRC-87A/C/D/F, AN/VRC-88A/D/F, AN/VRC-89A/D/F, AN/VRC-90A/D/F, AN/VRC-91A/D/F, and AN/VRC-92A/D/F)
TM 11-5820-890-20-3	Department of the Army Technical Manual (Unit Maintenance Manual, Ground ICOM Radio Sets: AN/PRC-119A, AN/VRC-87A, AN/VRC-88A, AN/VRC-89A, AN/VRC-90A, AN/VRC-91A, AN/VRC-92A)
TM 750-244-2	Procedure for Destruction of Electronics Materiel to Prevent Enemy Use (Electronics Command).

#### A.5. MISCELLANEOUS PUBLICATIONS.

AR 735-244-2	Reporting of Item and Packaging Discrepancies.
DA Pam 25-30	Consolidated Index of Army Publications and Blank Forms.
DA Pam 750-8	The Army Maintenance Management System (TAMMS).



**APPENDIX B**  
**MAINTENANCE ALLOCATION CHART**  
**(SEE TM 11-5820-890-20-2)**





**APPENDIX C**  
**EXPENDABLE/DURABLE SUPPLIES AND MATERIALS**

**SECTION I**

**INTRODUCTION**

**C.1. SCOPE.**

This listing is for informational purposes only. It does not give the authority to requisition the listed items below. These items are authorized to you by CTA 50-970, Expendable/Durable Items (Except Medical, Class V, Repair Parts, and Heraldic Items), or CTA 8-100, Army Medical Department Expendable/Durable Items.

**C.2. EXPLANATION OF COLUMNS.**

- a. Column (1)-Item Number. This number is assigned to the entry in the listing.
- b. Column (2)-Level. This column identifies the lowest level of maintenance that requires the listed item.  
 C - Operator/Crew  
 O - Unit Maintenance
- c. Column (3)-National Stock Number. This is the National Stock Number assigned to the item: use it to request and requisition the item.
- d. Column (4)-Description. Indicates the Federal item name. The last line for each item indicates the part number.
- e. Column (5)-Unit of Measure (U/M). Indicates the measure used in performing the actual maintenance function. If the unit of measure differs from the unit of issue, requisition the lowest unit of issue that will satisfy your requirements.

**SECTION II**

**EXPENDABLE/DURABLE SUPPLIES AND MATERIALS LIST**

(1) ITEM NO.	(2) LEVEL	(3) NSN	(4) DESCRIPTION	(5) U/M
1	0	8040-00-117-8510	Adhesive, Sealant. RTV Type III Clear	Tube
2	0	9150-00-857-9079	Grease (1), General Purpose. 130-AA	Lb.
3	0	8030-01-267-5398	Sealing Compound. MIL-S-22473 Grade H	Ea.
4	0	6850-00-177-5094	Silicone Compound. MIL-S-8660 Clear	Tube
5	0	8040-01-033-7507	Adhesive. 847	Tube
6	0	8040-01-281-2729	Adhesive. M46050-B-2-50	Ea.
7	0	6515-00-059-5235	Applicator, Disposable. GG-A-616	Pkg.
8	0	6810-01-190-2538	Isopropyl Alcohol, Technical. TT1735	Can



## SUBJECT MATTER INDEX

<u>Subject</u>	<u>Page</u>	<u>Subject</u>	<u>Page</u>
<b>A</b>		<b>C</b> Continued	
Administrative Storage .....	1-23	CX-13303/VRC .....	4-11
Amplifier, Radio Frequency AM-7238/VRC, AM-7238B/VRC .....	5-1	CX-13304/VRC .....	4-12
Amplifier-Adapter, Vehicular AM-7239 Series .....	3-3, 4-1	CX-13305/VRC .....	4-13
Antenna: AS-3900A/VRC, AS-3916/VRC, ....	1-0	CX-13306/VRC .....	4-14
Antenna, Manpack: AS-3683/PRC, AS-4266A/VRC .....	1-0	CX-13450/VRC .....	4-22
<b>B</b>		Component Repair .....	5-13
Battery Box: CY-8523A/PRC, CY-8523B/PRC,CY-8523C/PRC .....	1-0	Component Replacement .....	5-4
Battery, Non-Rechargeable BA-5372/U .....	1-7	Component Replacement/Repair .....	5-1
Battery, Non-Rechargeable BA-5590/U, .....	1-7	Consolidated Index of Army Publications .....	1-7
Battery, Rechargeable BA-390/U .....	1-7	Control-Monitor C-11291/VRC .....	1-7
Battery, Rechargeable BA-590/U .....	1-7	<b>D</b>	
<b>C</b>		DC Power Input and Distribution .....	1-9
Cables .....	4-1	DC Power Input and Distribution, Single ASIP Radio Mount .....	6-1
Cable Assembly, Radio Frequency, Electrical: CG-3855/VRC, CG-3856/VRC, W2 .....	4-4	Destruction of Army Electronics Materiel .....	1-7
Cable Assembly, Special Purpose, Electrical: CX-13291/VRC .....	4-5	<b>E</b>	
CX-13292/VRC .....	4-6	Expendable/Durable Supplies and Materials List, Appendix C .....	C-1
CX-13298/VRC .....	4-7	<b>F</b>	
CX-13300/VRC .....	4-8	Field Pack,Combat Nylon .....	1-0
CX-13301/VRC .....	4-9	Frequency Hopping Operation .....	1-17
CX-13308/VRC .....	4-15	<b>H</b>	
CX-13310/VRC .....	4-16	Handset H-250/U .....	1-2, 1-3, 1-4
CX-13311/VRC .....	4-17	Handset HRCRD .....	1-2
CX-13312/VRC .....	4-18	<b>I</b>	
CX-13313/VRC .....	4-19	Inspection Procedures .....	5-1
CX-13402/VRC .....	4-20	Intermediate Storage .....	1-24
CX-13417/VRC .....	4-21	<b>L</b>	
CX-13465/VRC .....	4-23	Loudspeaker-Control Unit LS-671/VRC ..	1-0, 5-9
W4 .....	4-24	Loudspeaker, Permanent Magnet LS-454 .....	1-7
W20 .....	4-25		
CDU Vehicular Adapter Cable .....	4-26		
Cable Assembly, Power, Electrical: CX-13302/VRC .....	4-10		

**SUBJECT MATTER INDEX** Continued

<u>Subject</u>	<u>Page</u>	<u>Subject</u>	<u>Page</u>
<b>M</b>		<b>R</b> Continued	
Manpack Radio .....	2-1	AN/VRC-88A/D/F (Short Range with Dismount Equipment) .....	1-3
Manpack Radio Assembly .....	2-1	AN/VRC-89A/D/F ( Short Range and Long Range) .....	1-4
Manpack Radio Operational Check .....	2-3	AN/VRC-90A/D/F (Short Range and Long Range) .....	1-4
Manpack Radio Troubleshooting Flowcharts ...	2-8	AN/VRC-90G (Long Range in Single ASIP Radio Mount) .....	1-6.1
Maintenance Forms, Records, and Reports ...	1-7	AN/VRC-91A/D/F ( Short Range and Long Range with Dismount Equipment) .	1-5
Mounting Base, Electrical Equipment MT-6352/VRC .....	1-0	AN/VRC-92A/D/F (Dual Long Range) .....	1-6
Mounting Base, Electrical Equipment MT-6353/VRC .....	1-0	Receive Signal Path .....	1-15
<b>N</b>		Receive Signal Path, Single ASIP Radio Mount .....	6-4
Nomenclature Cross-Reference List .....	1-7	Reporting Equipment Improvement Recommendations (EIR) .....	1-6
<b>O</b>		RT Main Panel Displays .....	1-18
Operational Check, Manpack Radio .....	2-3	RT Self-Test .....	1-19
Operational Check, Single ASIP Radio Mount ..	6-6	<b>S</b>	
Operational Check, Vehicular Radio .....	3-1	Special Procedures .....	1-23
<b>P</b>		Storage, Administrative .....	1-23
Post Repair Use of Operational Check .....	1-22	Storage, Intermediate .....	1-24
Power Amplifier .....	1-20	Survivable Low Profile Antenna (SLPA) .....	1-8
Preparation for Storage and Shipment .....	1-6	<b>T</b>	
Principles of Operation .....	1-9	Time Management .....	1-17
Principles of Operation, Single ASIP Radio Mount .....	6-1	Transmit Signal Path .....	1-15
Principles of Maintenance Operation .....	1-21	Transmit Signal Path, Single ASIP Radio Mount .....	6-5
<b>R</b>		Troubleshooting .....	1-21
Radio Set Components for:		Troubleshooting Flowcharts, Manpack Radio .	2-8
AN/PRC-119A/D/F (Manpack) .....	1-2	Troubleshooting Flowcharts, Single ASIP Radio Mount .....	3-8
AN/VRC-87A/D/F ( Short Range ) .....	1-2	Troubleshooting Flowcharts, Vehicular Radio .	3-8
AN/VRC-87G (Short Range in Single ASIP Radio Mount) .....	1-6.1	Typical SC Test Setup .....	1-22

## SUBJECT MATTER INDEX Continued

<u>Subject</u>	<u>Page</u>	<u>Subject</u>	<u>Page</u>
<b>U</b>		<b>V</b>	
Unscheduled Maintenance .....	1-21	Vehicular Radios .....	3-1
Use of Maintenance Allocation Chart .....	1-21		



<b>RECOMMENDED CHANGES TO PUBLICATIONS AND BLANK FORMS</b> For use of this form, see AR 25-30; the proponent agency is OAASA				Use Part II (reverse) for Repair Parts and Special Tool Lists (RPSTL) and Supply Catalogs/Supply Manuals (SC/SM).		DATE 30 August 2002	
<b>TO:</b> (Forward to proponent of publication or form) (Include ZIP Code) Commander, US Army CECOM LCMC ATTN: AMSEL-LC-LEO-E-ED Fort Monmouth, NJ 07703-5006				<b>FROM:</b> (Activity and location) (Include ZIP Code) Jane Q. Doe, SFC 1234 Any Street Anytown, AL 34565			
<b>PART I - ALL PUBLICATIONS (EXCEPT RPSTL AND SC/SM) AND BLANK FORMS</b>							
PUBLICATION/FORM NUMBER TM 11-1234-567-14				DATE 16 Sep 2001		TITLE Operator, Field and Sustainment Support Maintenance Manual for Radio, AN/ABC-123	
ITEM	PAGE	PARA-GRAPH	LINE	FIGURE NO.	TABLE	RECOMMENDED CHANGES AND REASON	
1	WP0005 PG 3		2			Test or Corrective Action column should identify a different WP number.	
TYPED NAME, GRADE OR TITLE Jane Q. Doe, SFC				TELEPHONE EXCHANGE/AUTOVON, PLUS EXTENSION 123-4567		SIGNATURE	

EXAMPLE

<b>TO:</b> (Forward to proponent of publication or form) (Include ZIP Code)	<b>FROM:</b> (Activity and location) (Include ZIP Code)	<b>DATE</b>
---	---	-------------

**PART II- REPAIR PARTS AND SPECIAL TOOL LISTS AND SUPPLY CATALOGS/SUPPLY MANUALS**

PUBLICATION/FORM NUMBER	DATE	TITLE
-------------------------	------	-------

PAGE NO.	COLM NO.	LINE NO.	NATIONAL STOCK NUMBER	REFERENCE NO.	FIGURE NO.	ITEM NO.	TOTAL NO. OF MAJOR ITEMS SUPPORTED	RECOMMENDED ACTION

**PART III - REMARKS** (Any general remarks, recommendations, or suggestions for improvement of publications and blank forms. Additional space may be used if more space is needed.)

EXAMPLE

TYPED NAME, GRADE OR TITLE	TELEPHONE EXCHANGE/AUTOVON, PLUS EXTENSION	SIGNATURE
----------------------------	--	-----------



<b>RECOMMENDED CHANGES TO PUBLICATIONS AND BLANK FORMS</b> For use of this form, see AR 25-30; the proponent agency is OAASA					Use Part II ( <i>reverse</i> ) for Repair Parts and Special Tool Lists (RPSTL) and Supply Catalogs/Supply Manuals (SC/SM).		DATE
TO: ( <i>Forward to proponent of publication or form</i> ) ( <i>Include ZIP Code</i> )					FROM: ( <i>Activity and location</i> ) ( <i>Include ZIP Code</i> )		
<b>PART I - ALL PUBLICATIONS (EXCEPT RPSTL AND SC/SM) AND BLANK FORMS</b>							
PUBLICATION/FORM NUMBER					DATE		TITLE
ITEM	PAGE	PARA-GRAPH	LINE	FIGURE NO.	TABLE	RECOMMENDED CHANGES AND REASON	
TYPED NAME, GRADE OR TITLE				TELEPHONE EXCHANGE/AUTOVON, PLUS EXTENSION		SIGNATURE	

<b>TO:</b> (Forward to proponent of publication or form) (Include ZIP Code)	<b>FROM:</b> (Activity and location) (Include ZIP Code)	<b>DATE</b>
---	---	-------------

**PART II- REPAIR PARTS AND SPECIAL TOOL LISTS AND SUPPLY CATALOGS/SUPPLY MANUALS**

PUBLICATION/FORM NUMBER			DATE		TITLE			
PAGE NO.	COLM NO.	LINE NO.	NATIONAL STOCK NUMBER	REFERENCE NO.	FIGURE NO.	ITEM NO.	TOTAL NO. OF MAJOR ITEMS SUPPORTED	RECOMMENDED ACTION

**PART III - REMARKS** (Any general remarks or recommendations, or suggestions for improvement of publications and blank forms. Additional blank sheets may be used if more space is needed.)

TYPED NAME, GRADE OR TITLE	TELEPHONE EXCHANGE/AUTOVON, PLUS EXTENSION	SIGNATURE
----------------------------	--	-----------

<b>RECOMMENDED CHANGES TO PUBLICATIONS AND BLANK FORMS</b> For use of this form, see AR 25-30; the proponent agency is OAASA						Use Part II ( <i>reverse</i> ) for Repair Parts and Special Tool Lists (RPSTL) and Supply Catalogs/Supply Manuals (SC/SM).	DATE
<b>TO:</b> ( <i>Forward to proponent of publication or form</i> ) ( <i>Include ZIP Code</i> )						<b>FROM:</b> ( <i>Activity and location</i> ) ( <i>Include ZIP Code</i> )	
<b>PART I - ALL PUBLICATIONS (EXCEPT RPSTL AND SC/SM) AND BLANK FORMS</b>							
PUBLICATION/FORM NUMBER						DATE	TITLE
ITEM	PAGE	PARA-GRAPH	LINE	FIGURE NO.	TABLE	RECOMMENDED CHANGES AND REASON	
TYPED NAME, GRADE OR TITLE				TELEPHONE EXCHANGE/AUTOVON, PLUS EXTENSION		SIGNATURE	

<b>TO:</b> (Forward to proponent of publication or form) (Include ZIP Code)	<b>FROM:</b> (Activity and location) (Include ZIP Code)	<b>DATE</b>
---	---	-------------

**PART II- REPAIR PARTS AND SPECIAL TOOL LISTS AND SUPPLY CATALOGS/SUPPLY MANUALS**

PUBLICATION/FORM NUMBER			DATE		TITLE			
PAGE NO.	COLM NO.	LINE NO.	NATIONAL STOCK NUMBER	REFERENCE NO.	FIGURE NO.	ITEM NO.	TOTAL NO. OF MAJOR ITEMS SUPPORTED	RECOMMENDED ACTION

**PART III - REMARKS** (Any general remarks or recommendations, or suggestions for improvement of publications and blank forms. Additional blank sheets may be used if more space is needed.)

TYPED NAME, GRADE OR TITLE	TELEPHONE EXCHANGE/AUTOVON, PLUS EXTENSION	SIGNATURE
----------------------------	--	-----------

<b>RECOMMENDED CHANGES TO PUBLICATIONS AND BLANK FORMS</b> For use of this form, see AR 25-30; the proponent agency is OAASA						Use Part II ( <i>reverse</i> ) for Repair Parts and Special Tool Lists (RPSTL) and Supply Catalogs/Supply Manuals (SC/SM).	DATE
<b>TO:</b> ( <i>Forward to proponent of publication or form</i> ) ( <i>Include ZIP Code</i> )						<b>FROM:</b> ( <i>Activity and location</i> ) ( <i>Include ZIP Code</i> )	
<b>PART I - ALL PUBLICATIONS (EXCEPT RPSTL AND SC/SM) AND BLANK FORMS</b>							
PUBLICATION/FORM NUMBER						DATE	TITLE
ITEM	PAGE	PARA-GRAPH	LINE	FIGURE NO.	TABLE	RECOMMENDED CHANGES AND REASON	
TYPED NAME, GRADE OR TITLE				TELEPHONE EXCHANGE/AUTOVON, PLUS EXTENSION		SIGNATURE	

<b>TO:</b> (Forward to proponent of publication or form) (Include ZIP Code)	<b>FROM:</b> (Activity and location) (Include ZIP Code)	<b>DATE</b>
---	---	-------------

**PART II- REPAIR PARTS AND SPECIAL TOOL LISTS AND SUPPLY CATALOGS/SUPPLY MANUALS**

PUBLICATION/FORM NUMBER			DATE		TITLE			
PAGE NO.	COLM NO.	LINE NO.	NATIONAL STOCK NUMBER	REFERENCE NO.	FIGURE NO.	ITEM NO.	TOTAL NO. OF MAJOR ITEMS SUPPORTED	RECOMMENDED ACTION

**PART III - REMARKS** (Any general remarks or recommendations, or suggestions for improvement of publications and blank forms. Additional blank sheets may be used if more space is needed.)

TYPED NAME, GRADE OR TITLE	TELEPHONE EXCHANGE/AUTOVON, PLUS EXTENSION	SIGNATURE
----------------------------	--	-----------

By Order of the Secretary of the Army:

DENNIS J. REIMER  
*General, United States Army*  
*Chief of Staff*

Official:

  
JOEL B. HUDSON

*Administrative Assistant to the*  
*Secretary of the Army*  
05825

DISTRIBUTION:

To be distributed in accordance with the initial distribution number (IDN) 511756 requirements for TM 11-5820-890-20-1

★ U.S. GOVERNMENT PRINTING OFFICE: 1999 - 710-117/80149







